



Single Stage Stainless Steel Pump



Stainless Steel Impeller

Construction

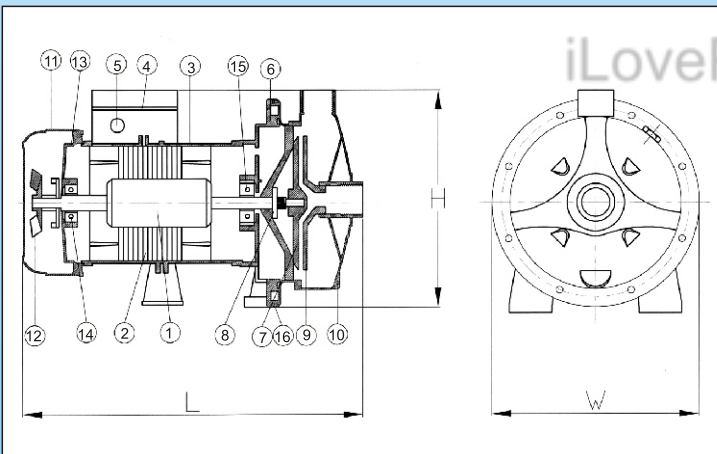

Performance curve

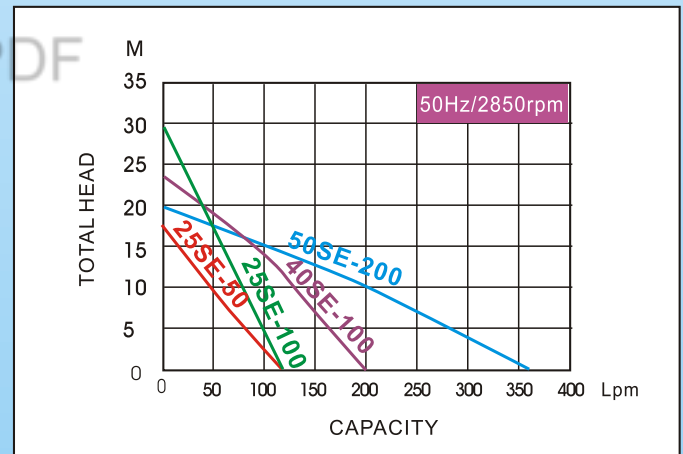

Specifications

TYPE	POWER		DISCHARGE		VOLTAGE	MAXIMUM		DIMENSION (mm)			WEIGHT
	HP	KW	INCH	mm		Head(M)	Q(LPM)	H(mm)	L(mm)	W(mm)	
25SE-50	1/2	0.4	1"	25	1PH/220V~240V or 3PH/380V~415V	18	120	200	340	160	12
25SE-100	1	0.75	1"	25		30	120	230	356	214	13
40SE-100	1	0.75	1-1/2"	40		24	200	230	356	214	13.1
50SE-200	2	1.5	2"	50		20	360	308	373	194	20

Parts list

No.	Description	Material	O'ty
1	Rotor & shaft	SUS410	1
2	Stator		1
3	Stator Housing	Aluminum	1
4	Terminal Box (upper)	ABS	1
5	Terminal Box (lower)	ABS	1
6	Front Endshield	Aluminum	1
7	Mid Plate	SUS 304	1
8	Mechanical Seal	CE/CA	1
9	Impeller	SUS 304	1
10	Pump Housing	SUS 304	1
11	Fan Cover	Steel	1
12	Fan	Nylon 66	1
13	Endshield	FC-00	1
14	Bearing		1
15	Bearing		1
16	O-Ring	NBR	1



★ Inverter Booster System available on Request