

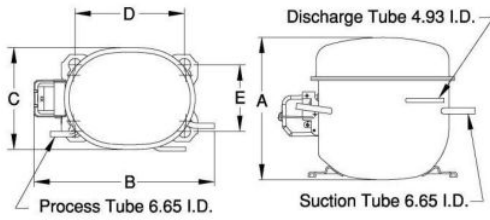

PRINCIPAL DIMENSIONS - mm



A: 184	B: 272	C: 155	D: 165	E: 102
--------	--------	--------	--------	--------

SCHEMATIC WIRING DIAGRAM R.S.I.R.

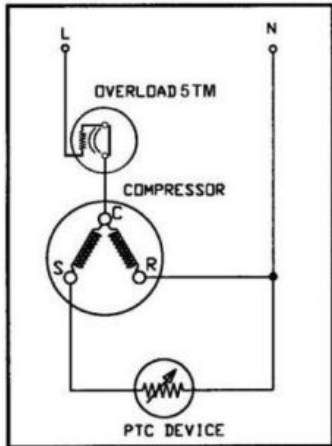

SCHEMATIC WIRING DIAGRAM -

MOUNTING KIT

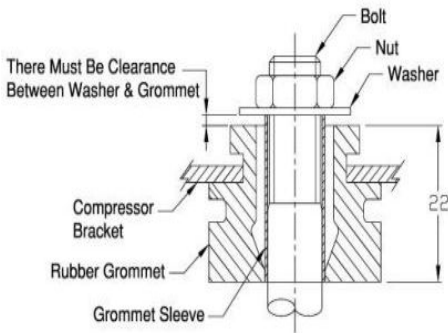

Electrical : 220-240 V/50 Hz. 1 Phase

Nominal Performance

Capacity	210 / - Watts
	717 / - BTU/Hr
	181 / - Kcal/Hr
Power Input	161 / - Watts
Locked Rotor Amps	10.00 / - Amps
Max Continuous Current	- / - Amps
Rated Load Amps	1.10 / - Amps
COP	1.30 / - Watts / Watts
EER	4.45 / - BTU/W-Hr

Testing Conditions

Condensing Temperature	54.40 °C	129.9 °F
Evaporating Temperature	-23.30 / - °C	-9.9 / - °F
Liquid Temperature	32.20 °C	90.0 °F
Return Gas Temperature	32.20 °C	90.0 °F
Ambient Temperature	32.20 °C	90.0 °F

Application

Evaporating Temp. Range	LBP	@ -34.40 °C to -12.20 °C (-29.9° F to 10.0° F)
	Heat Pump	- °C to - °C (-° F to -° F)
Refrigerant	R134a	
Refrigerant Flow Control	Capillary Tube	
Compressor Cooling	Natural Convection	

Compressor and Motor data

Compressor Type	Reciprocating
Displacement	7.63 cc.
Oil Type	Polyolester Oil
Oil Charge	300 cc.
Motor Type	R.S.I.R. ; 2 Pole 2,850 / - r/m
Voltage Range	187-264/- Volts 50/- Hz.
Winding Resistance at 25 °C	
Start	34.50 Ohms
Run	10.40 Ohms
Weight with Oil	9.26 Kg.
Weight with Oil and Accessories	9.46 Kg.

Electrical Components

Motor Protector	
Type	External 5TM
Model Number	4042KME670-29
Open / Close	115-125 / 70-52 °C
1st Cycle trip at 25 °C	9.50 Amps(main) - Amps(start)
Motor Starter	
Type	PTC Relay
Model Number	4043KME693-4 (PTH7M150MC1)
Pick Up (max.)	- Amps
Drop Out (min.)	- Amps
Terminal Cover	KMD 902-2
Start Capacitor	- µF - VAC.
Disch Resistor for Start Cap	-
Run Capacitor	- µF - VAC.

Mounting Kit

Rubber Grommet	4007KMD905-3
Sleeve Grommet	3KMD903-2-Z
Washer	4023KEB387

Since we are constantly improving our product , the specification are subject to change without notice.

REV. DATE
02-07-15

C / N No.
0283/15

Certificate Marks

