

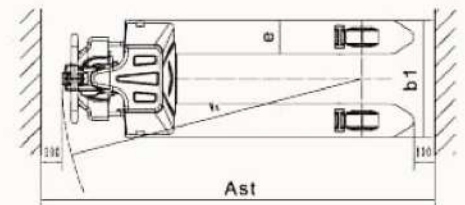

# WEPT20FB

## WEPT20FB SERIES WALKING ELECTRIC PALLET TRUCK

High Strength Streamlined Body.  
 Electric walking, electric lifting.  
 Equipped with emergency reverse switch,  
 emergency brake button is safer.  
 Battery can be replaced quickly.

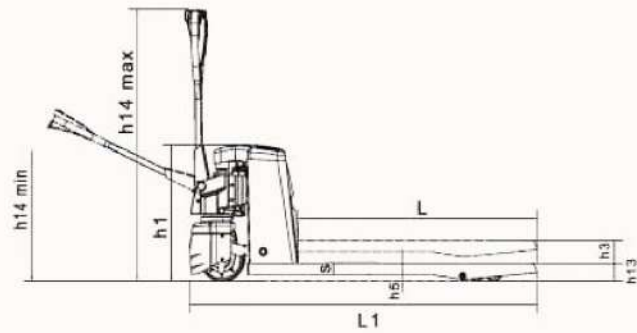

Model		WEPT20FB
Load capacity	kg	2000
Fork lowered	h13/mm	85
Lift height	h3/mm	115
Overall length	L1/mm	1670
Overall width	mm	560/685
Fork dimensions	mm	55/160/1150
Outside fork width	b1/mm	560/685
1000×1200 Aisle width, 1000×1200 pallet crossways	mm	1920
1000×1200 Aisle width, 800×1200 pallet crossways	mm	1920
Outer turning radius	mm	1480
Driver moter		24V 0.75kw
Lifting moter		24V 0.5kw
Battery		24V30Ah
Service weight	kg	150/155

