

bombas
IDEAL

SERIE **CP / CPI / CPH / CPR**



50Hz

60Hz

UNE 166.002

BUREAU VERITAS
Certification



ISO 9001

BUREAU VERITAS
Certification



ISO 14001

BUREAU VERITAS
Certification



Índice / Index



Diseño y construcción Desing and construction Dessin et construction		2
Campos de trabajo Performance charts Champs de travail		3
Diagramas Performance curves Diagrammes	50 Hz	6
Diagramas Performance curves Diagrammes	60 Hz	23
Límites de funcionamiento Operational limits Limites de fonctionnement		33
Dimensiones Dimensions		34
Sección Sectional view Section		36
Materiales de fabricación Materials of construction Materiaux de construction		38

● **Diseño y construcción**

Bombas centrífugas de cámara partida de una y dos etapas con las bridas de aspiración e impulsión fundidas en su cuerpo inferior para permitir un fácil acceso y desmontaje de las partes móviles evitando la desconexión de las tuberías.

Los impulsores han sido diseñados con la más alta tecnología para garantizar el mejor rendimiento dentro del campo útil de trabajo de cada bomba. Dependiendo del modelo, pueden incorporar dos impulsores en disposición espalda contra espalda, o un solo rodete de doble aspiración, de modo que el empuje axial quede siempre compensado.

La estanqueidad hidráulica en el eje se consigue mediante empaquetadura con casquillo protector del eje u opcionalmente mediante cierre mecánico normalizado.

Fabricación estandar en construcción horizontal, disposición vertical bajo demanda.

Aplicaciones

La amplia gama de bombas presentada, con caudales hasta 3000 l/s y alturas hasta 190 mca permite una gran diversidad de usos, incluyendo riegos, abastecimientos de agua potable, estaciones depuradoras, instalaciones de calefacción y aire acondicionado, equipos contra incendios, trasiego de líquidos en plantas industriales, minas, construcciones, etc.

Adecuación para manejar líquidos limpios o ligeramente contaminados y con temperaturas hasta 90° C.



● **Desing and construction**

Split case pumps containing one or two stages with the suction and discharge flanges casted in the bottom half casing, obtain better access and easy disassembly of the rotating parts, avoiding having to disconnect the pipework.

The impellers have been designed with the highest technology to guarantee the best posible efficiency within the capacity range of each pump, Depending on the pump model, it could incorporate two impellers in a "back to back" arrangement, or just a double suction one, as the axial pressure rate always remains compensated.

Hydraulic seal on the shaft is obtained either by means of shaft sleeve with packing, or standarized mechanical seal.

Horizontal execution as standard, vertical disposal on request.

Applications

The broad pump range shown, with discharges up to 3000 l/s and heads up to 190 metres, allows a wide diversity of use, including irrigation, circulation of drinkable water, water purifier stations, heating and air conditioning installations, fire fighting pump sets, circulation of liquids at industrial plants, mines, construction, etc. Suitable to handle clean or slightly polluted liquids, with temperatures up to 90°C.

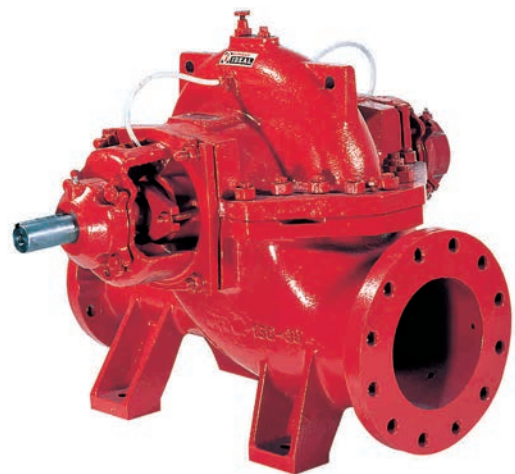

● **Dessin et construction**

Pompes centrifuges à chambre divisée à ou deux étages.

Les brides d'aspiration de refoulement sont coulées dans le corps inférieur pour permettre d'y accéder et de démonter les parties mobiles plus facilement sans avoir à enlever les tuyauteries.

Les roues été dessinées en utilisant la plus haute technologie pour garantir un meilleur rendement dans le champ utile de travail de chaque pompe. Selon le modèle, peuvent être incorporées deux roues épaulement contre épaulement, ou une seule roue de double aspiration, de manière à ce que la pression axiale soit toujours compensée.

Fabrication standard en execution horizontal, vertical sur demande.

Applications

Cette vaste gamme de pompes est utilisée des débits jusqu'à 3000 l/s et des hauteurs jusqu'à 190 m. Elle est spécialement conçue pour différentes utilisations, comme l'arrosage, l'approvisionnement d'eau potable, les stations d'épuration, les installations de chauffage et d'air conditionné, des équipes contre-incendies, le transvasement de liquides dans des installations industrielles, des mines, la construction, etc.

Ces pompes doivent travailler avec les liquides propres ou légèrement chargés, à des températures jusqu'à 90°C.



50Hz

Campos de Trabajo / Performance Charts / Champs de Travail

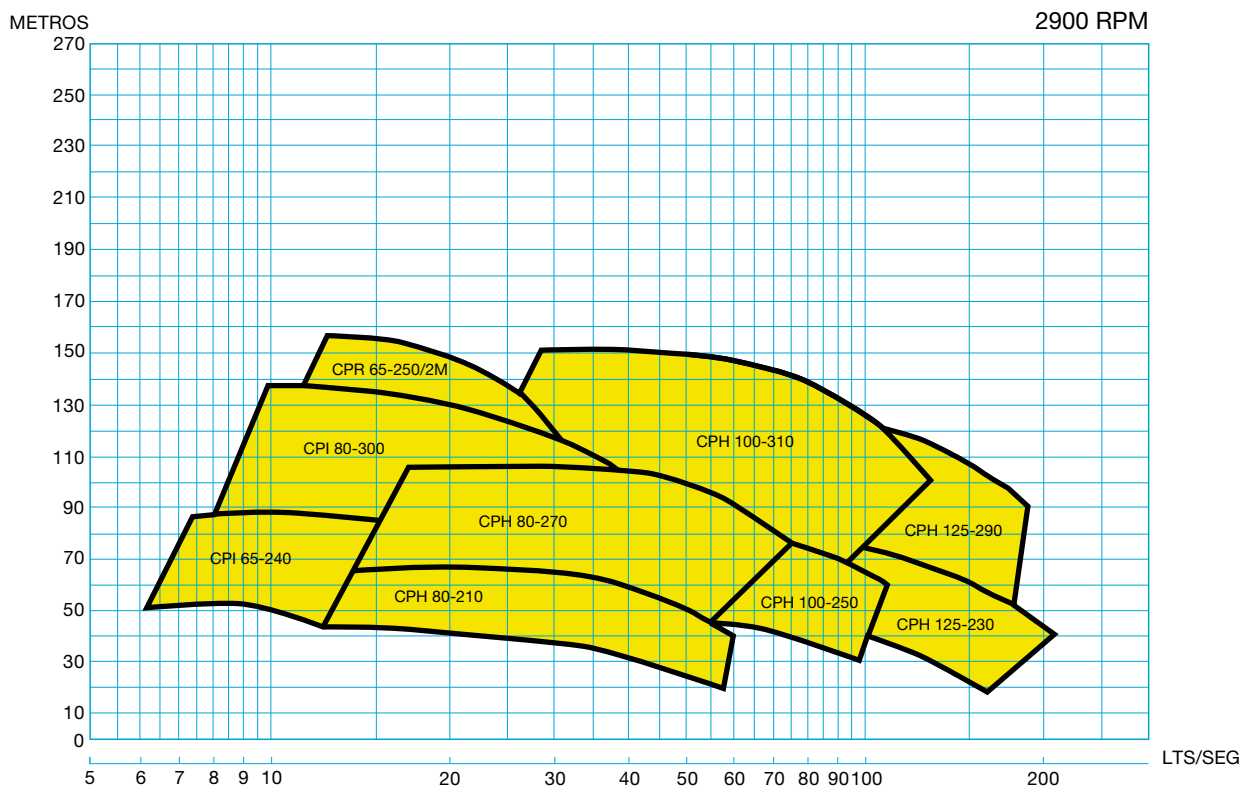

50Hz

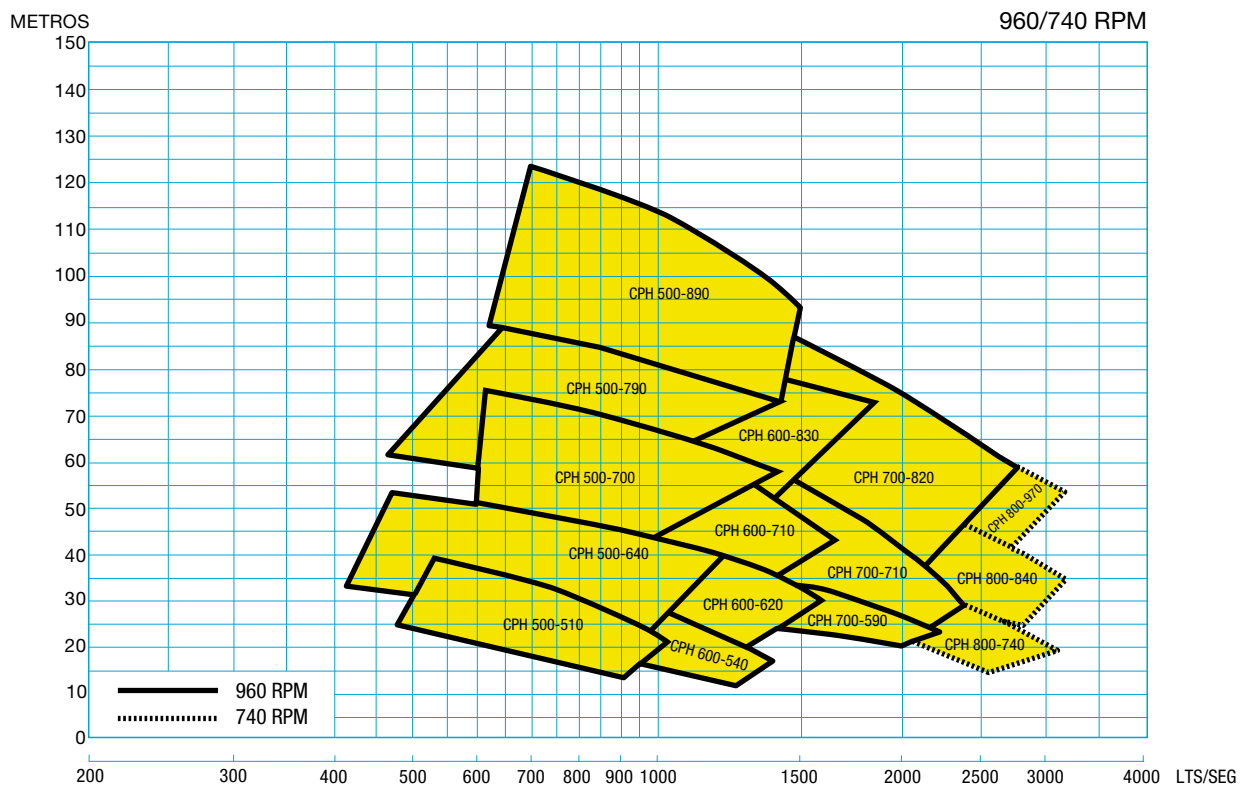

Campos de Trabajo / Performance Charts / Champs de Travail

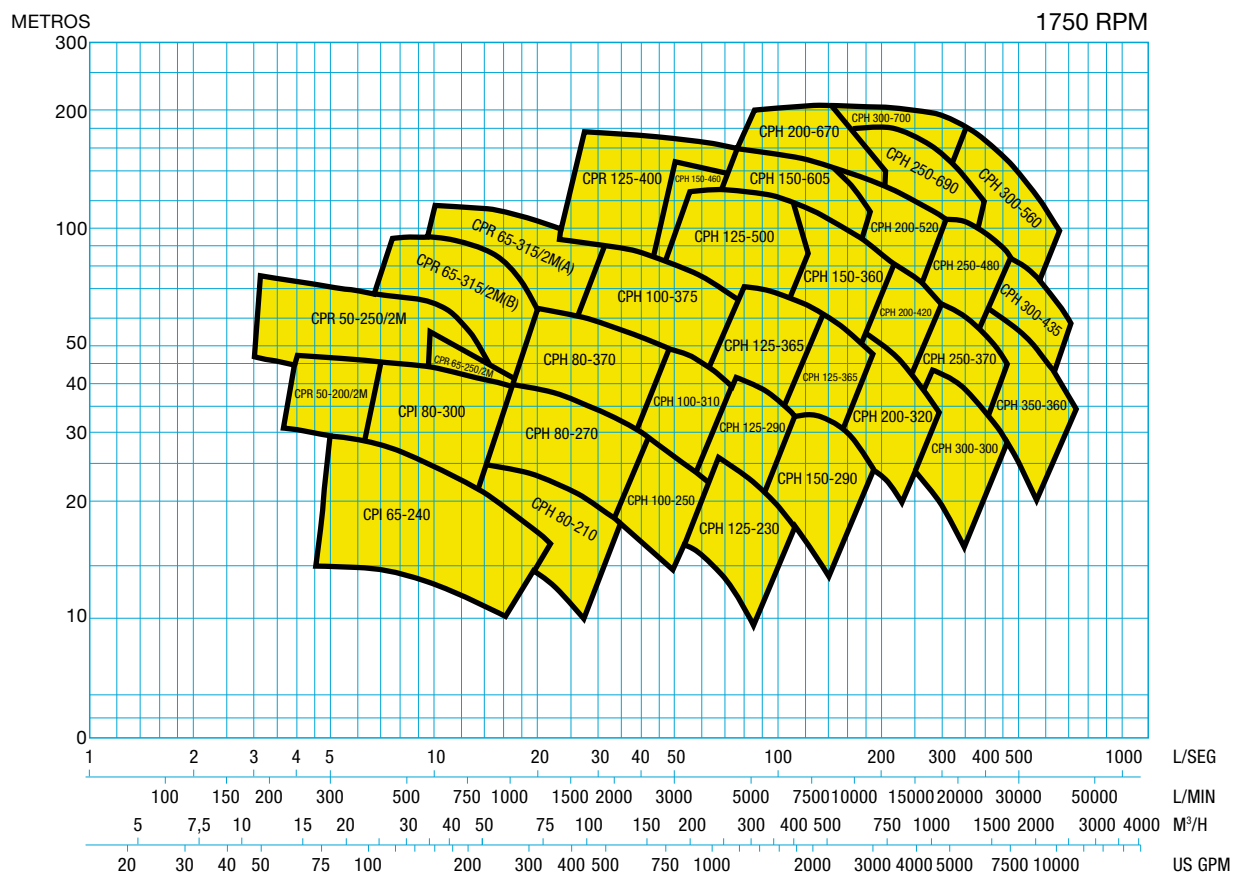
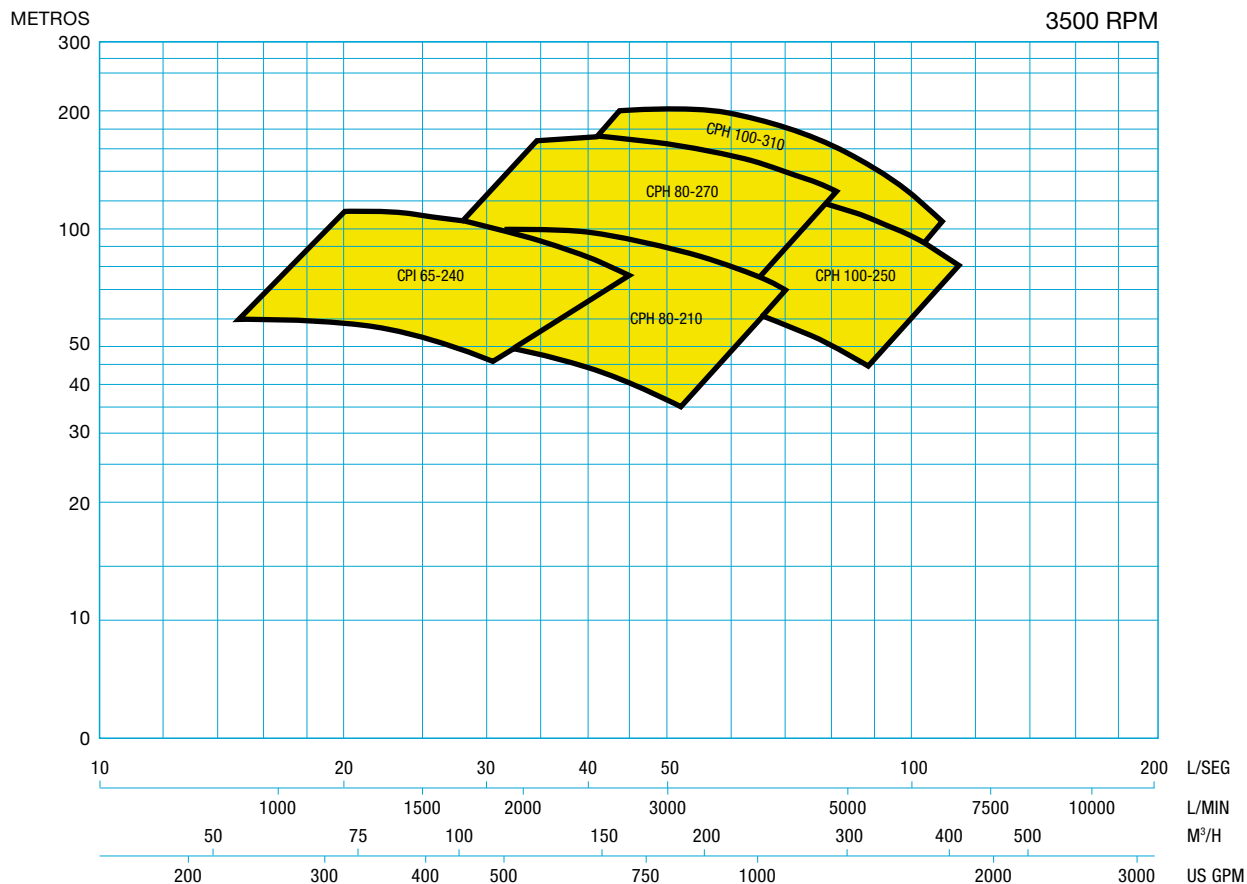

60Hz

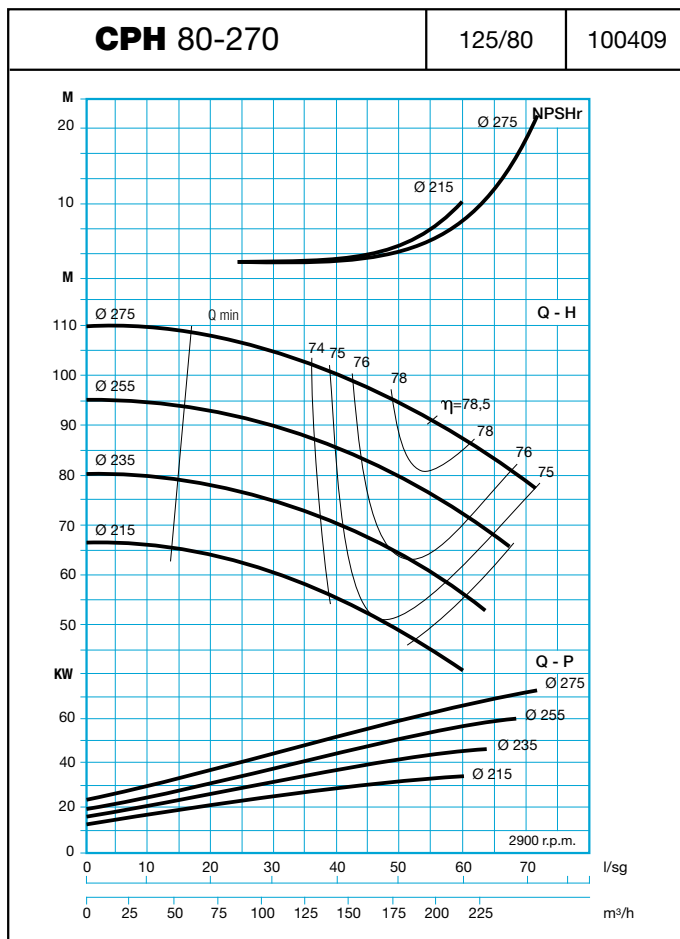
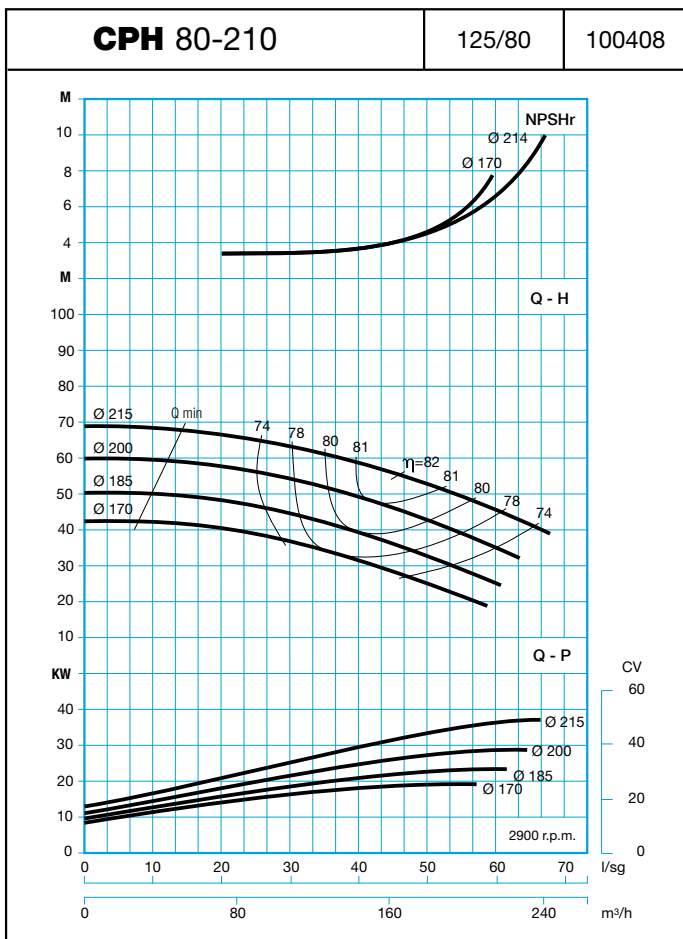
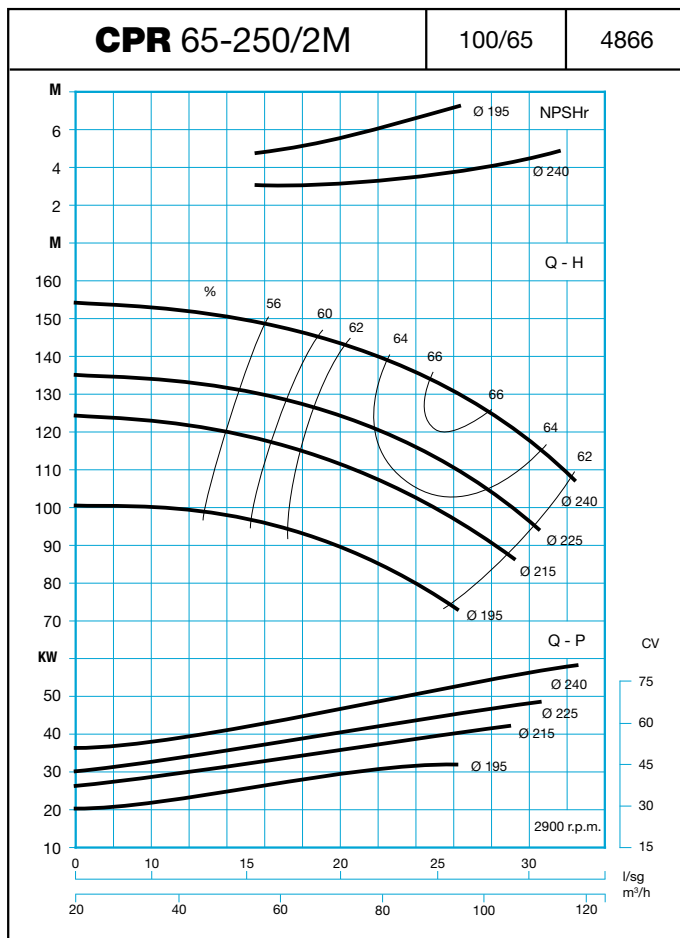
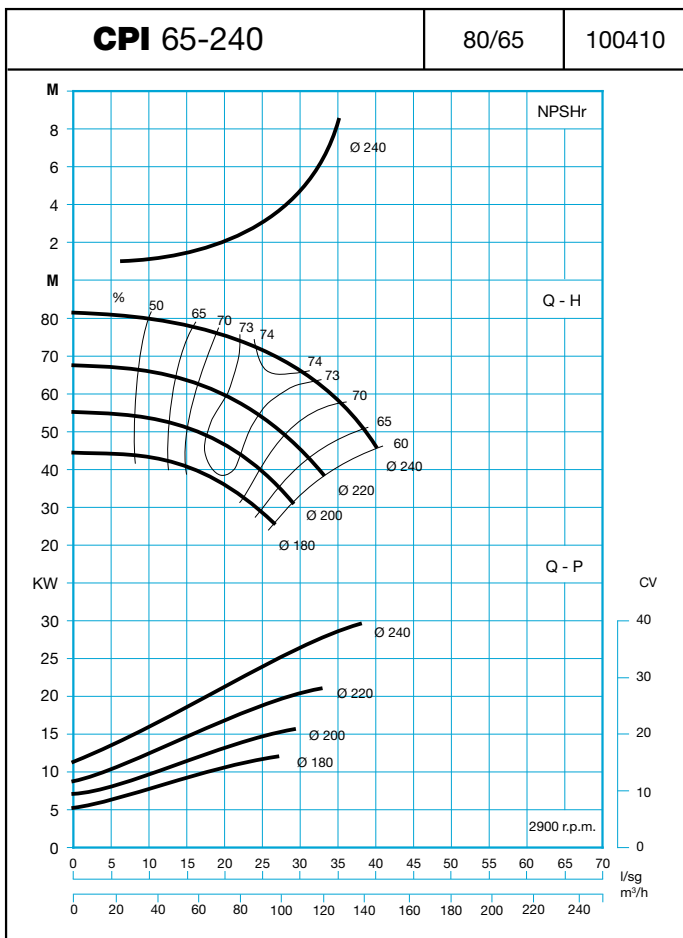

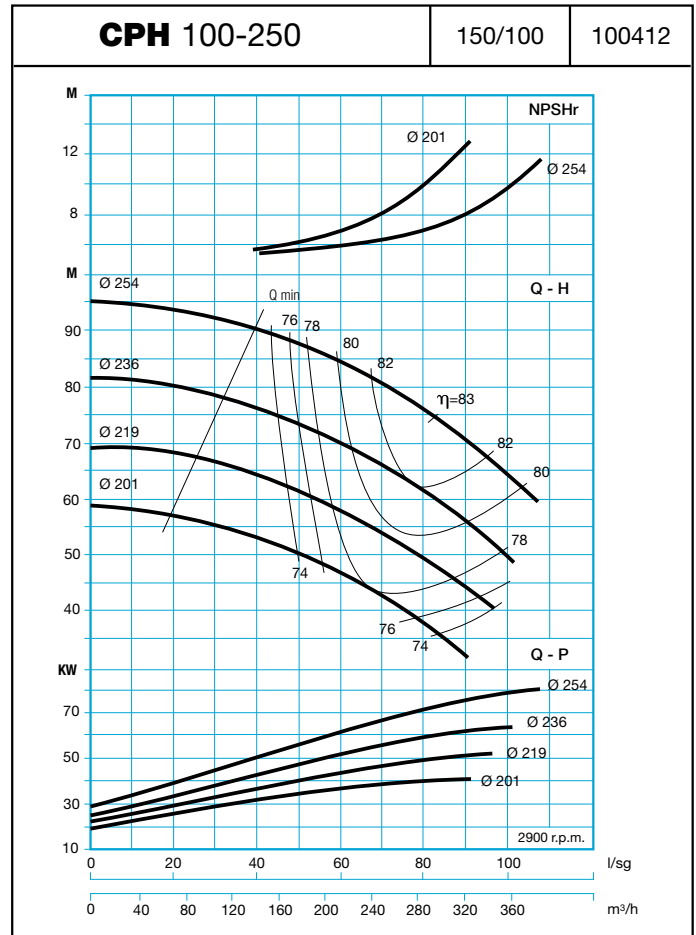
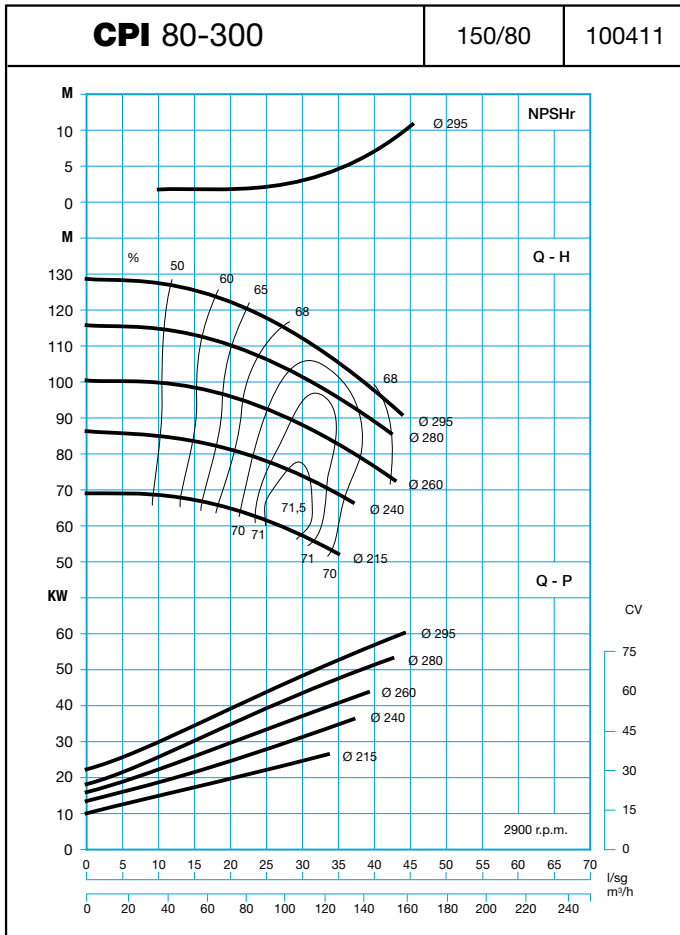

50Hz / 2900 RPM

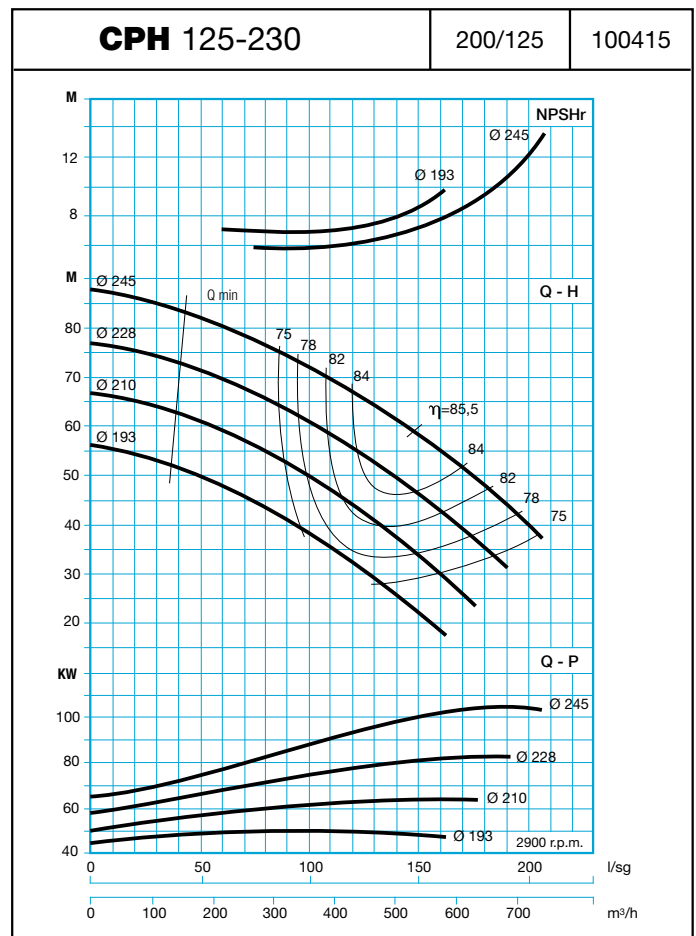
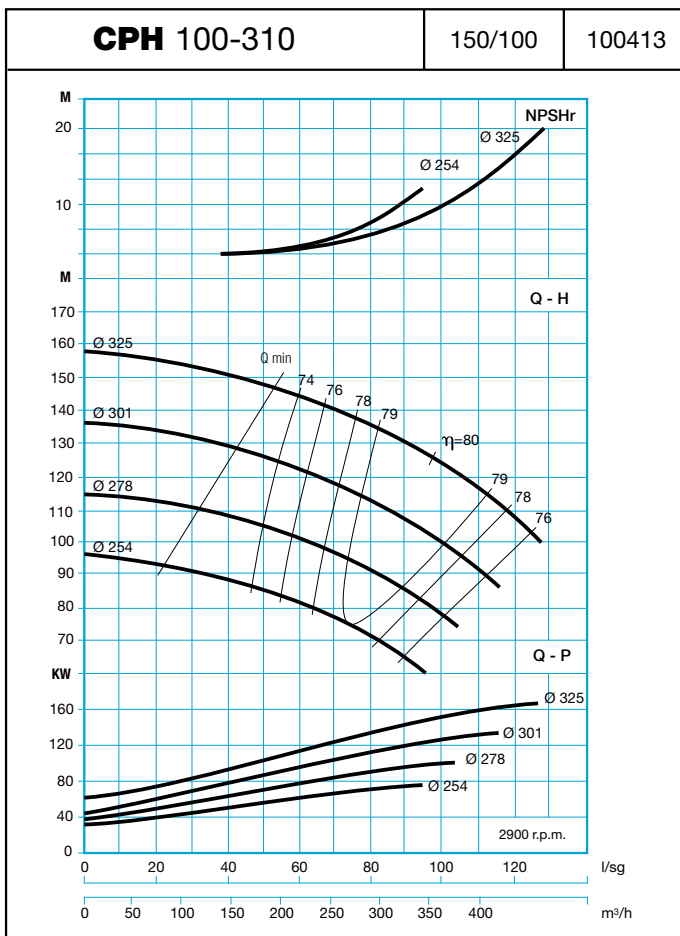

50Hz / 2900 RPM / 1450 RPM

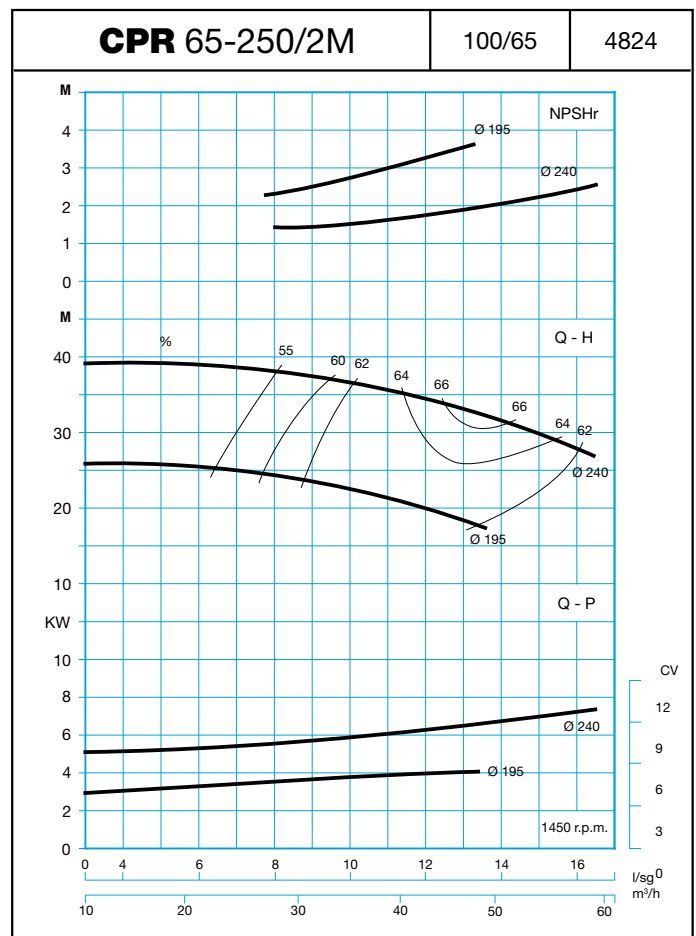
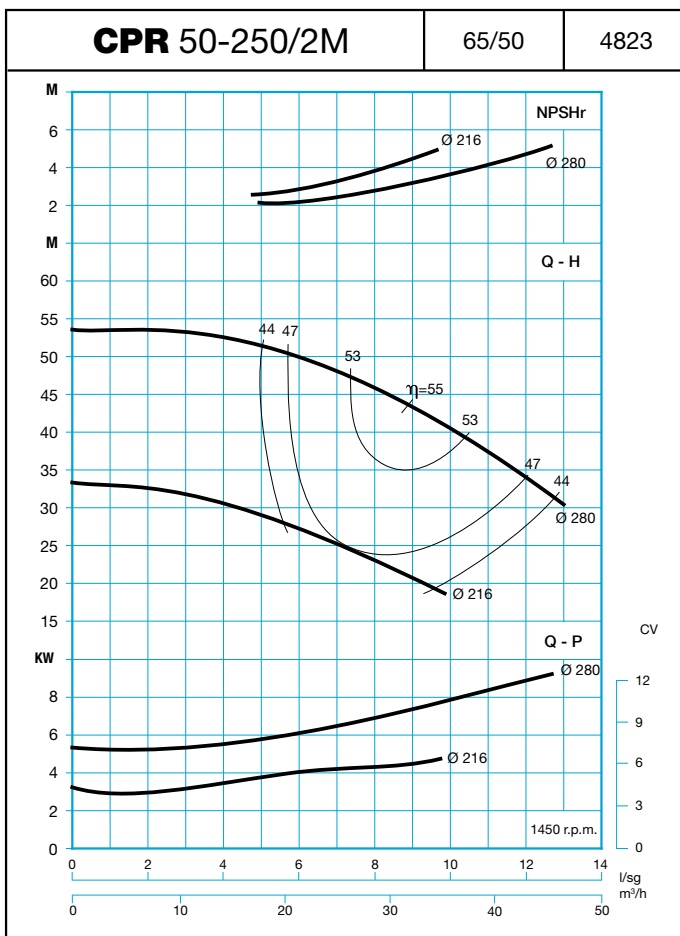
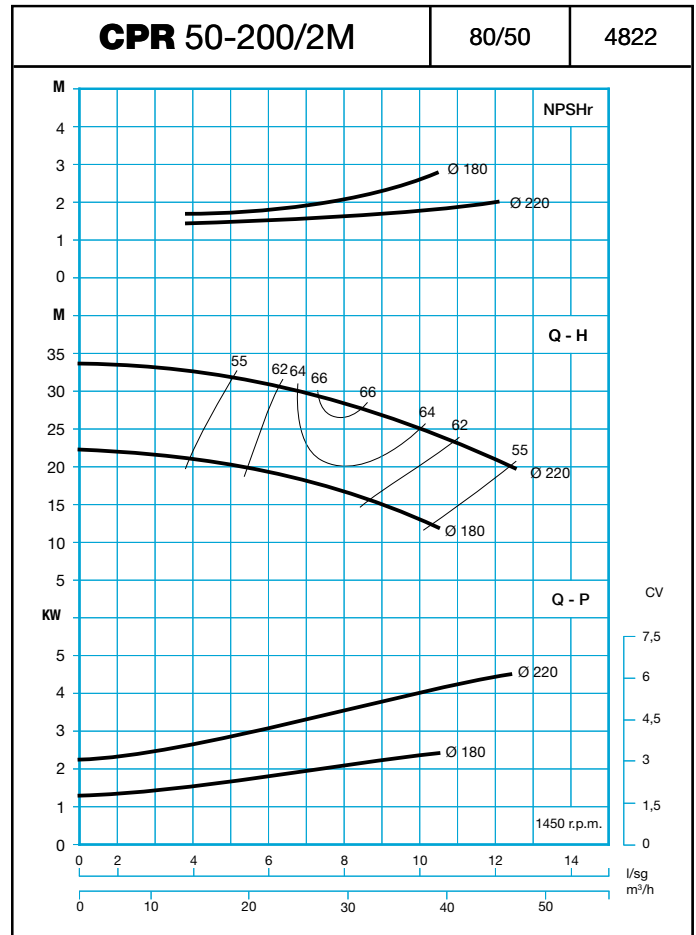
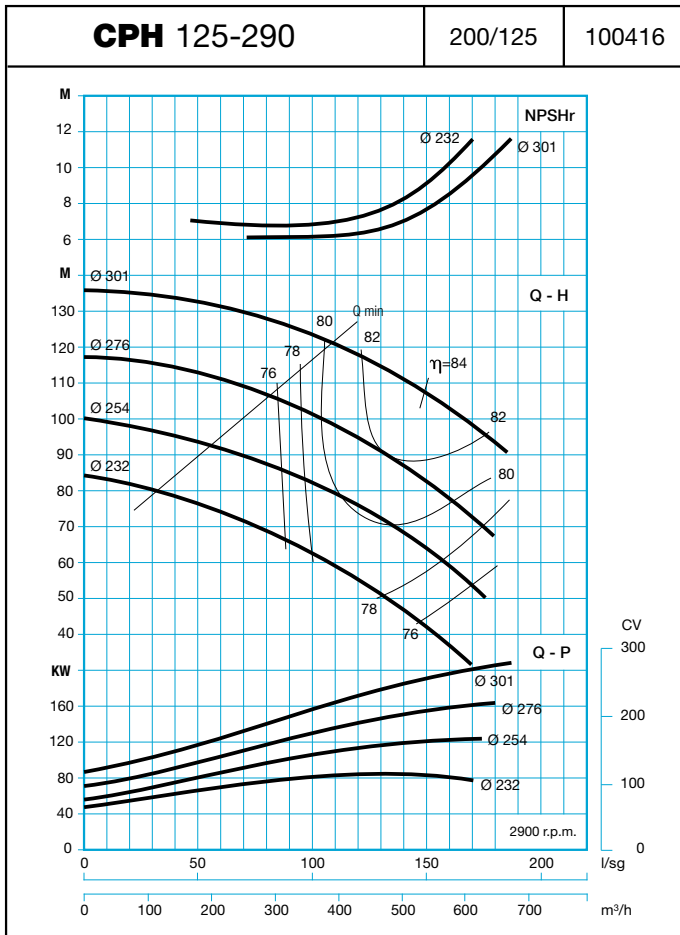

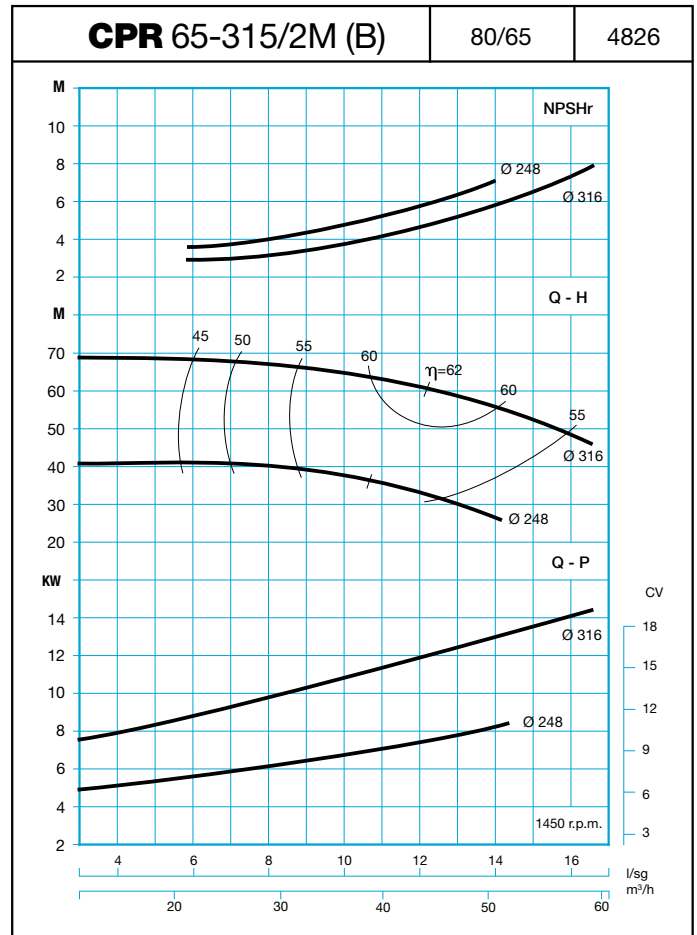
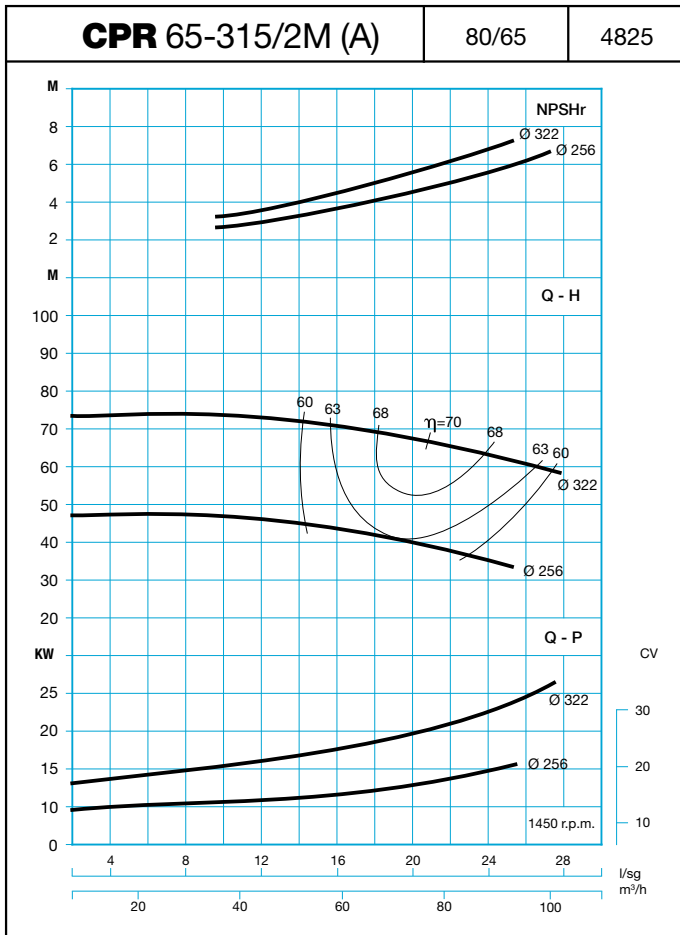

50Hz / 1450 RPM

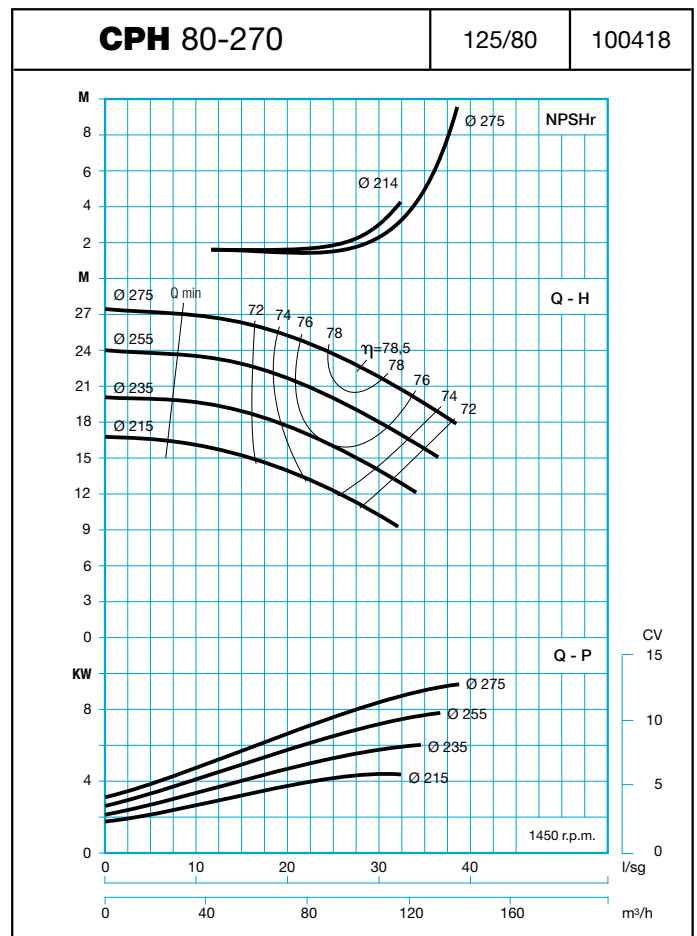
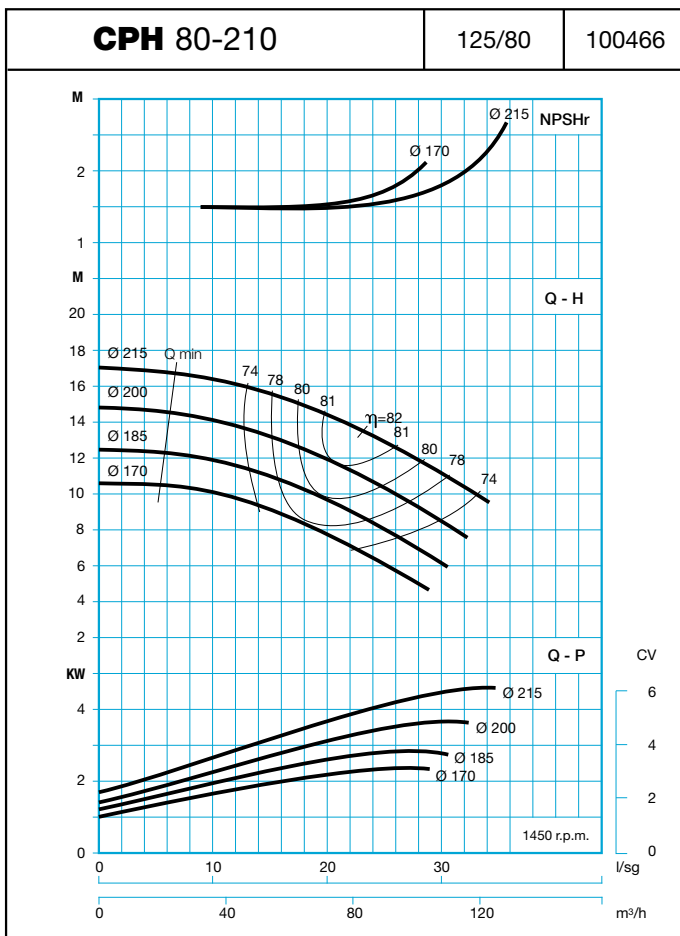

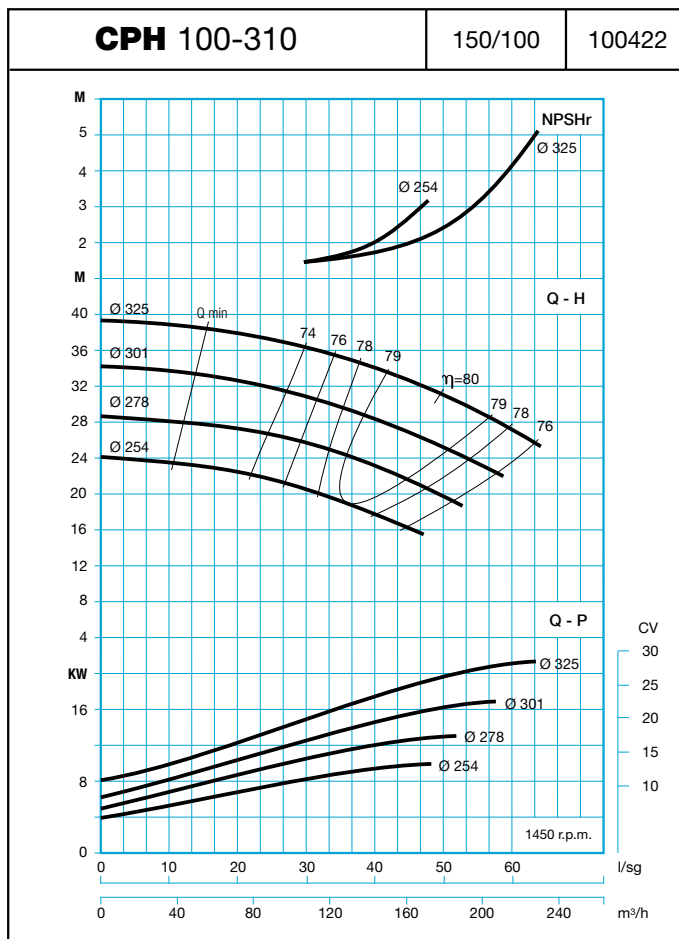
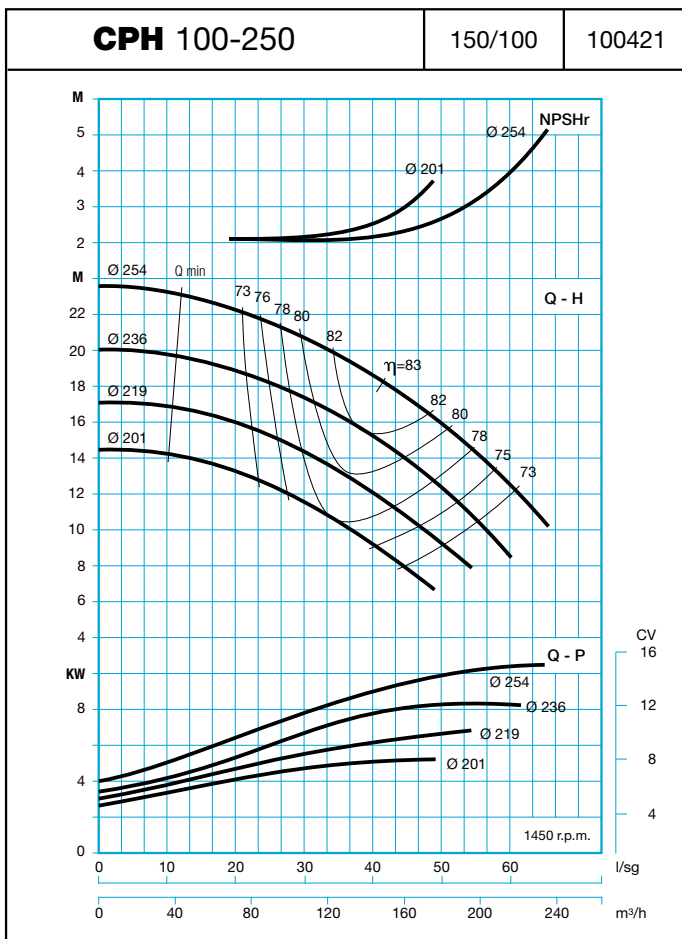
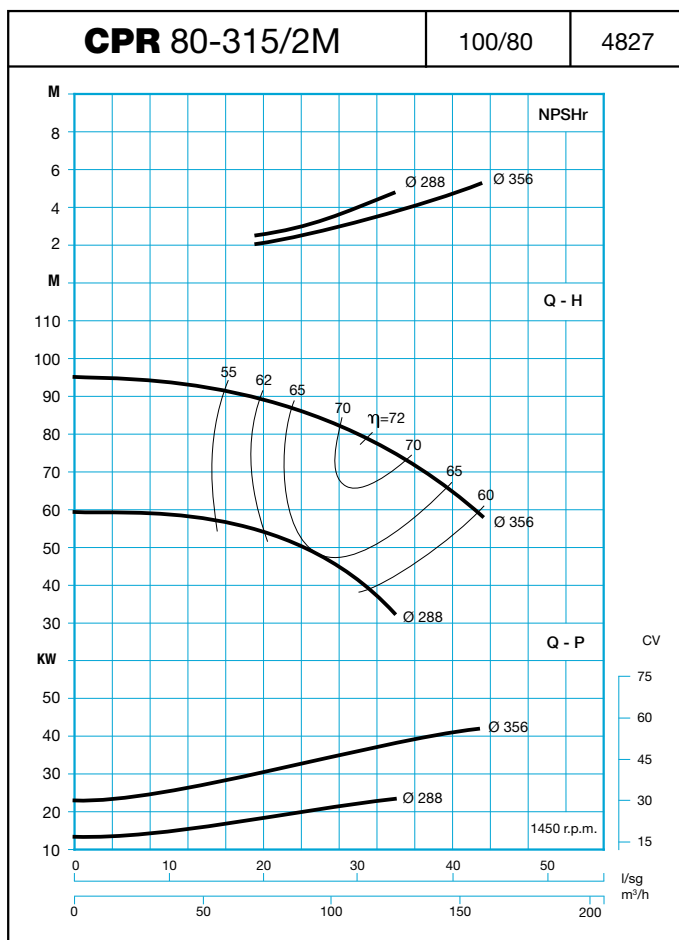
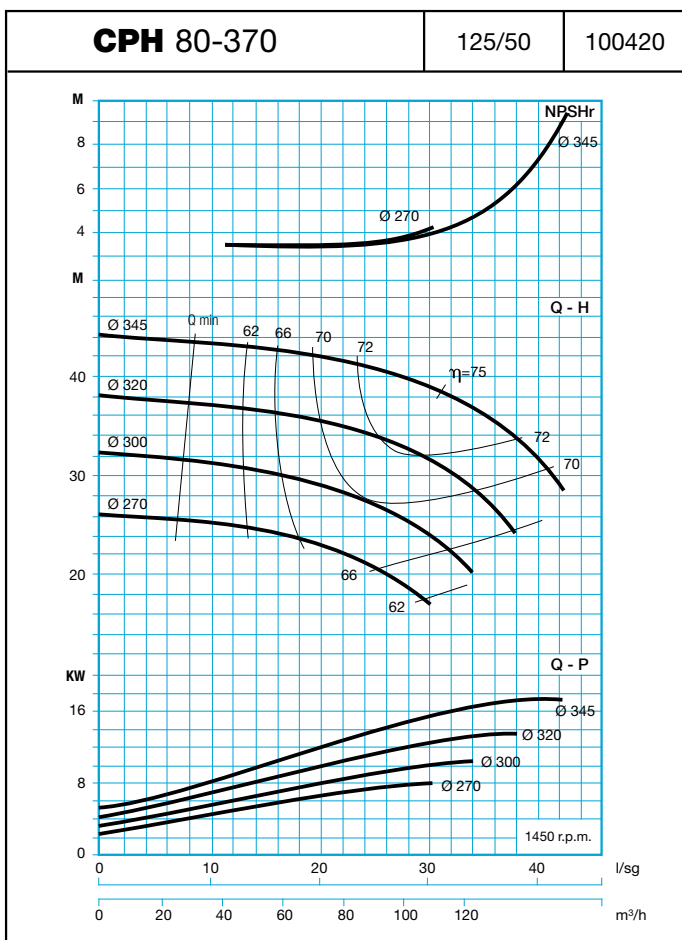

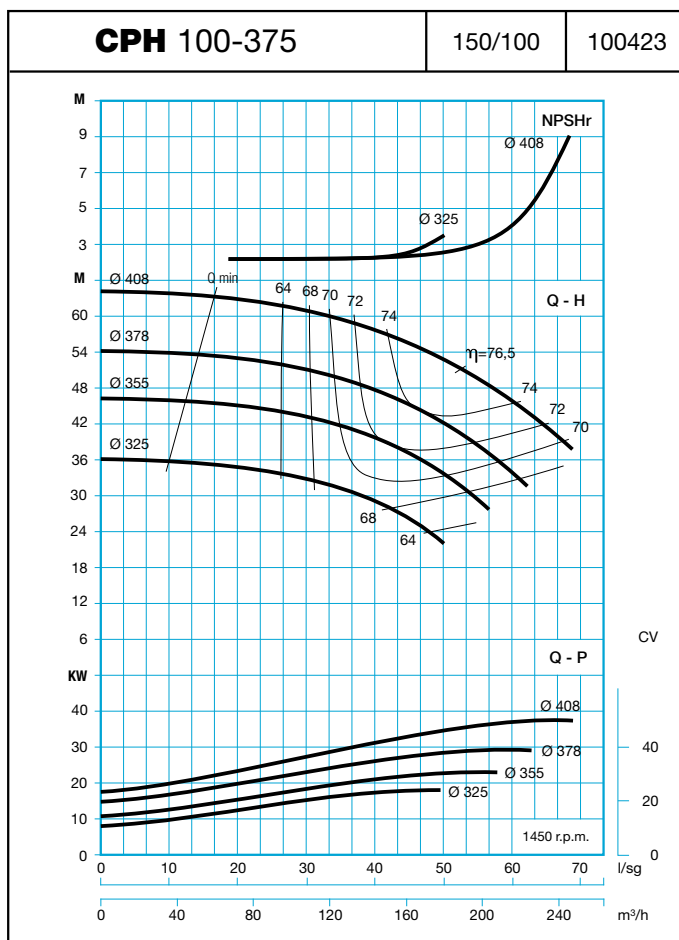
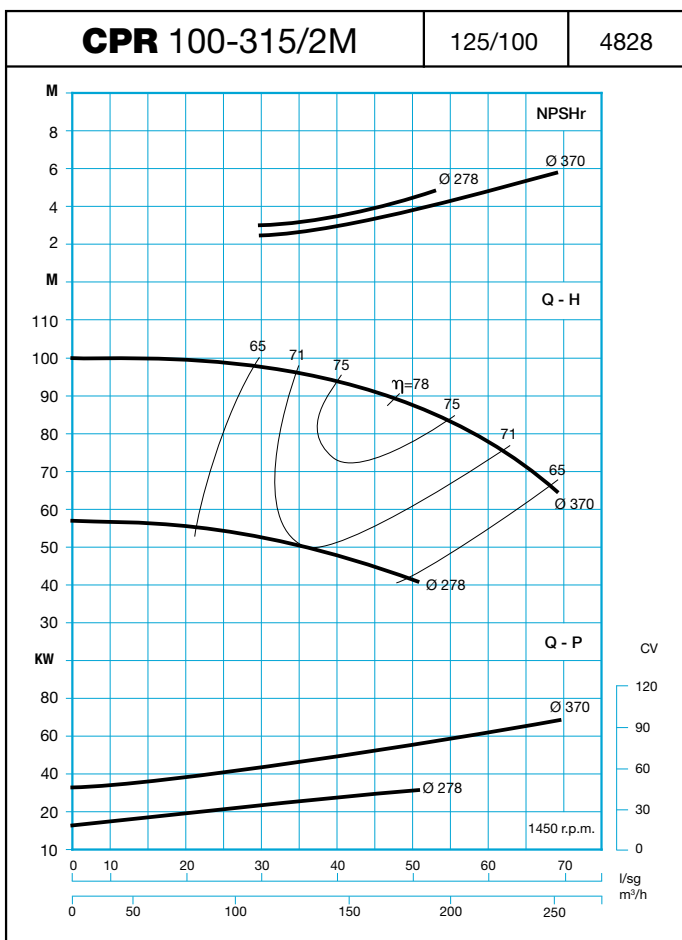

50Hz / 1450 RPM

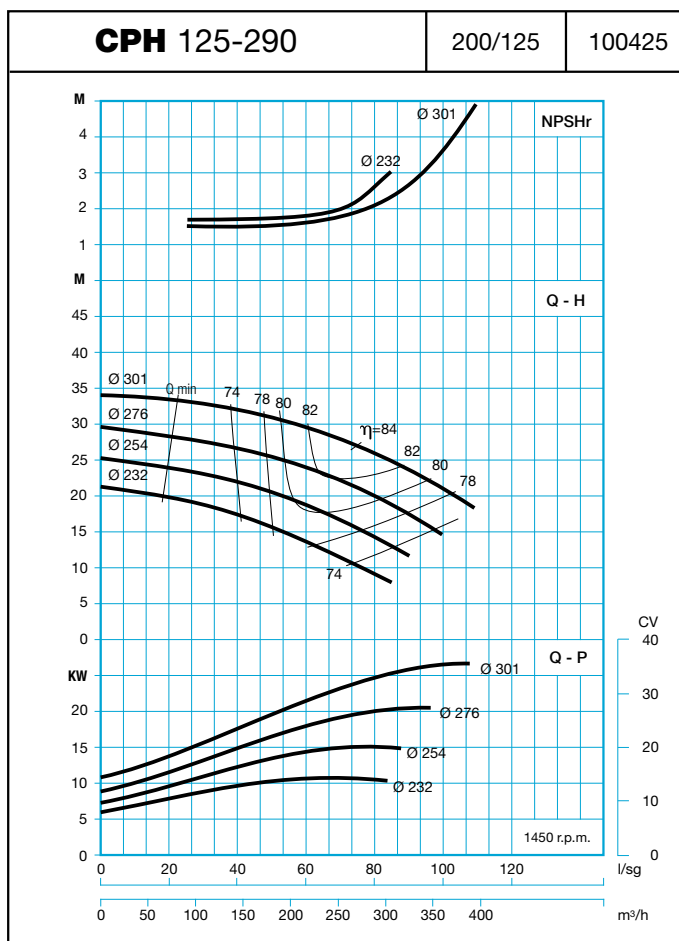
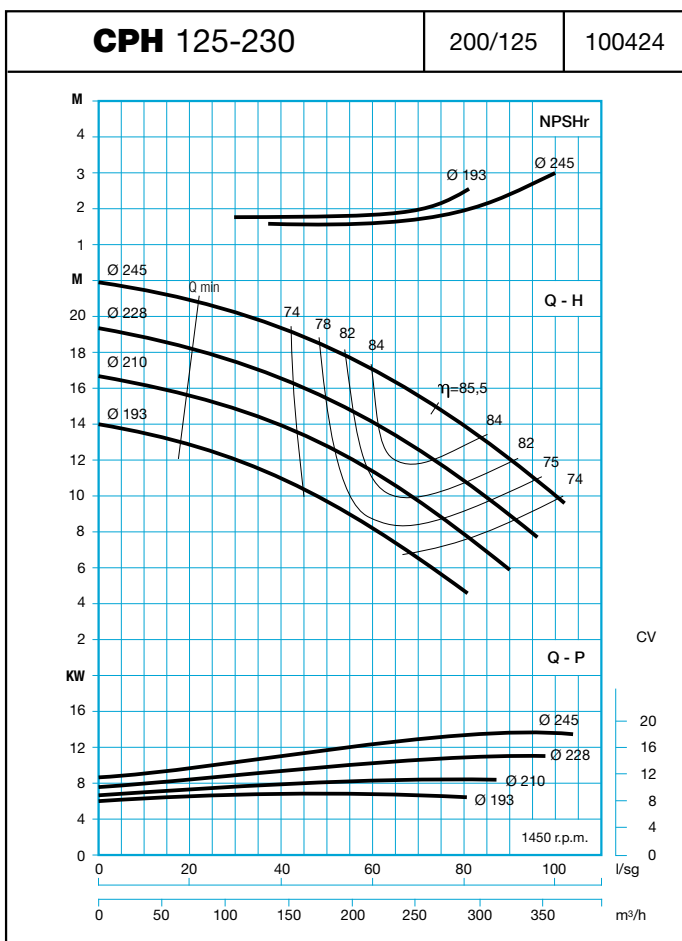

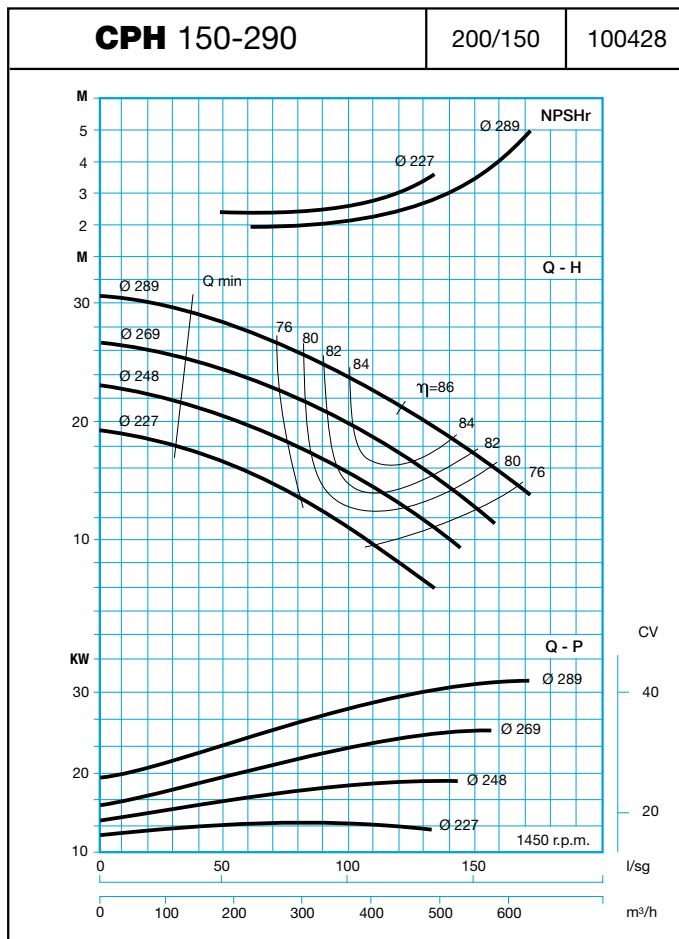
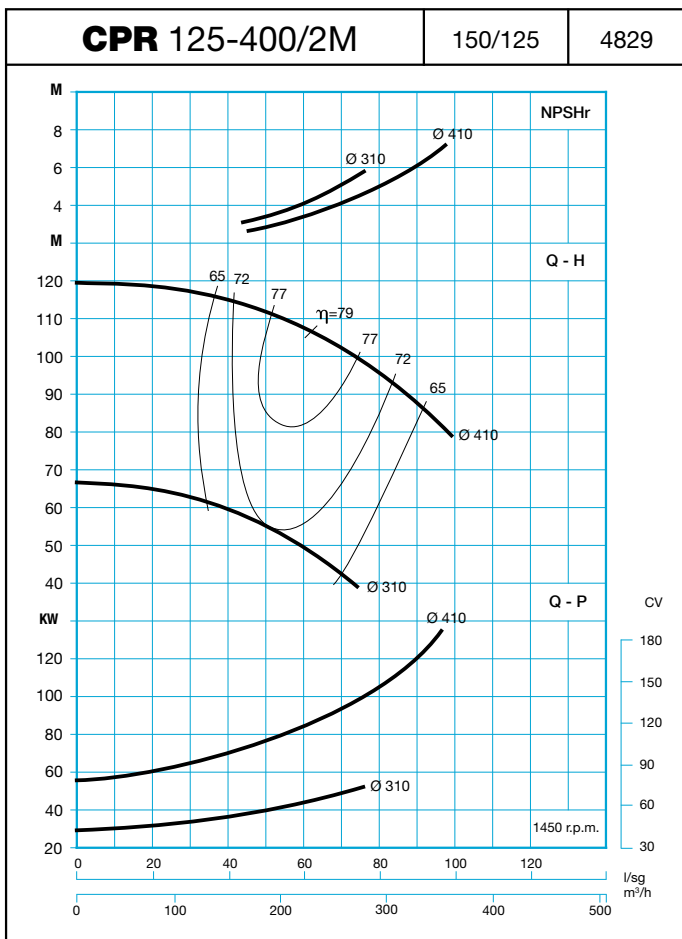
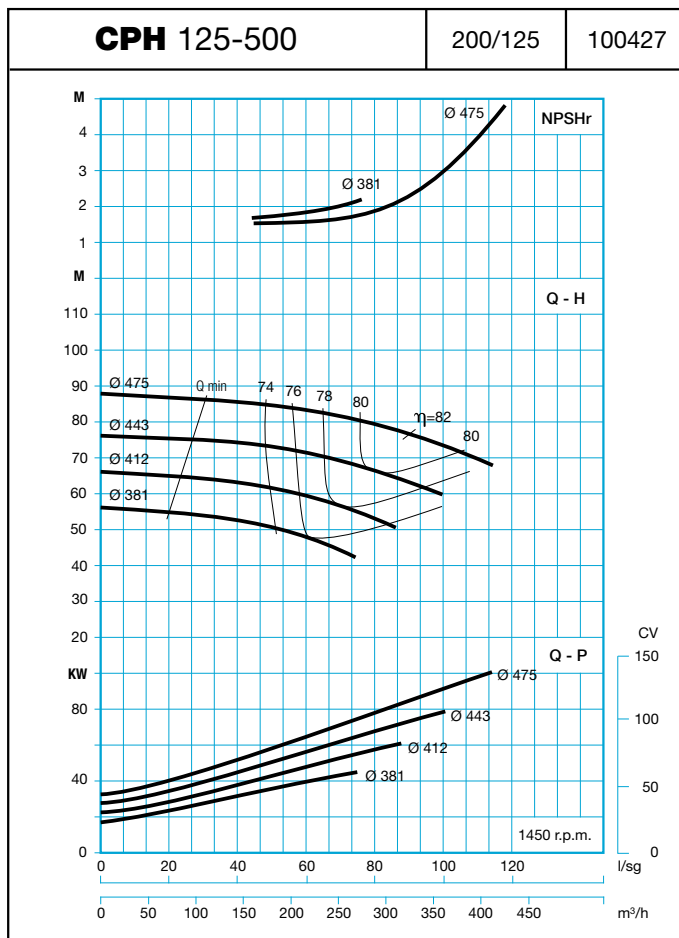
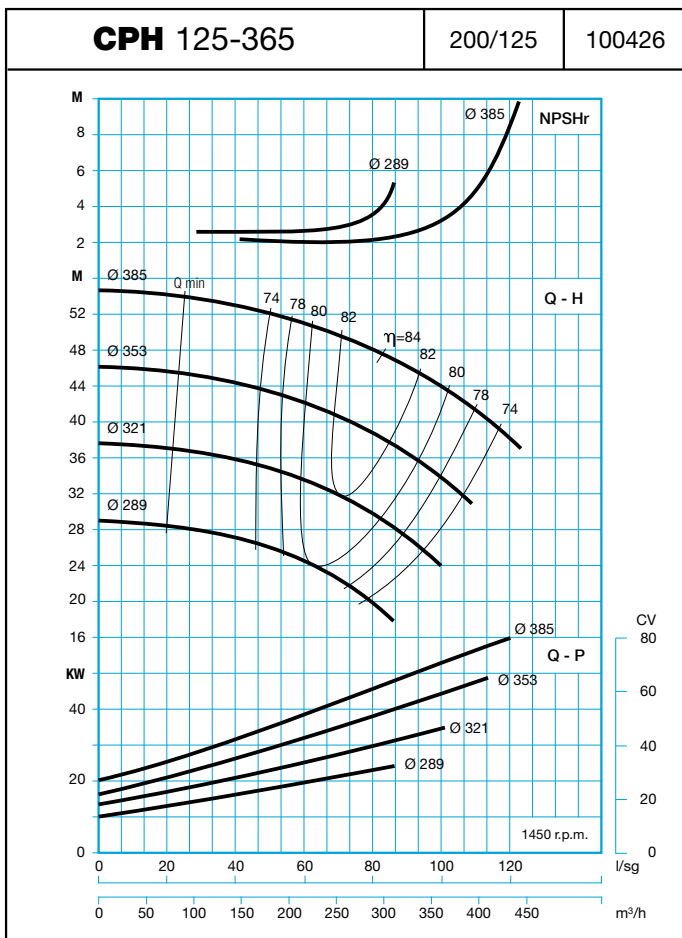

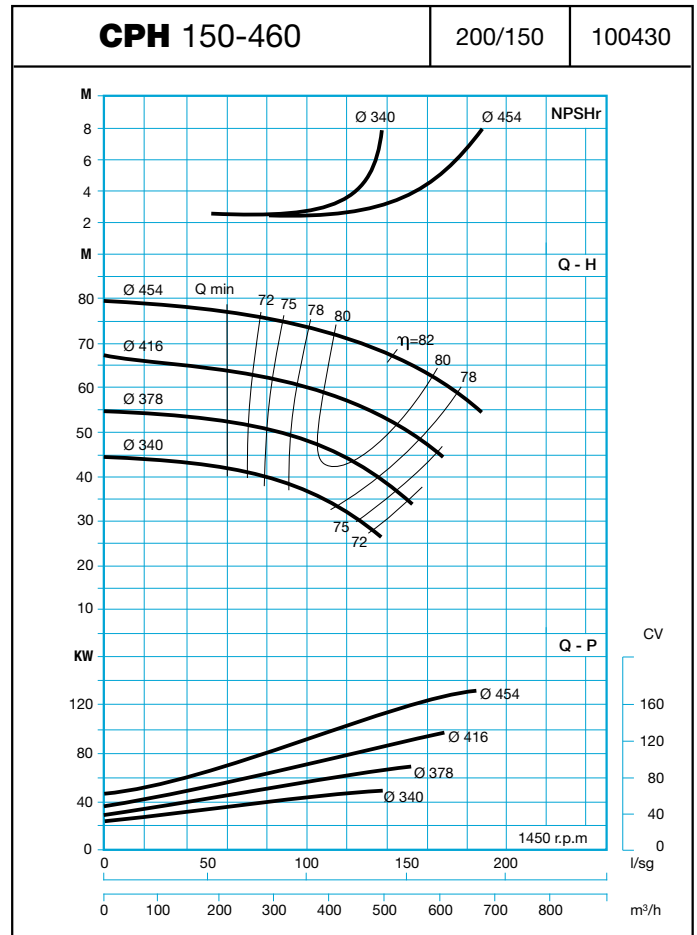
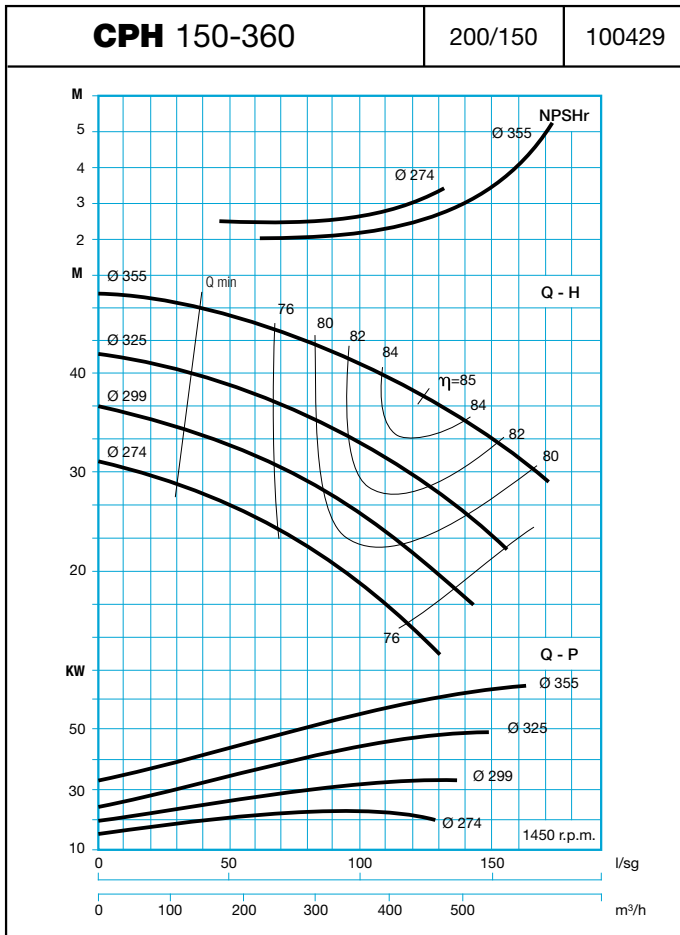

50Hz / 1450 RPM

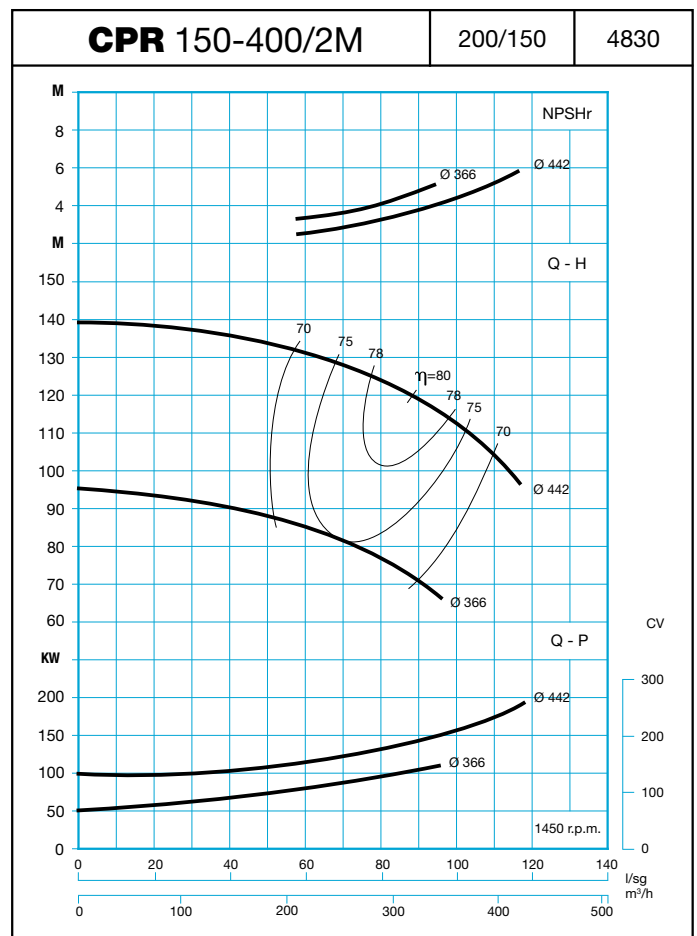
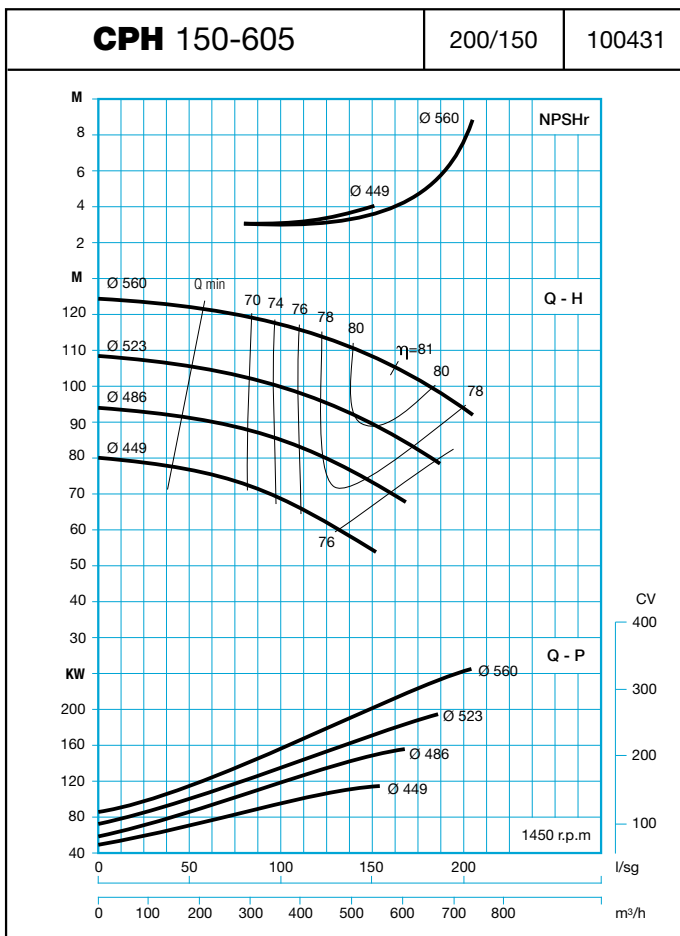

50Hz / 1450 RPM

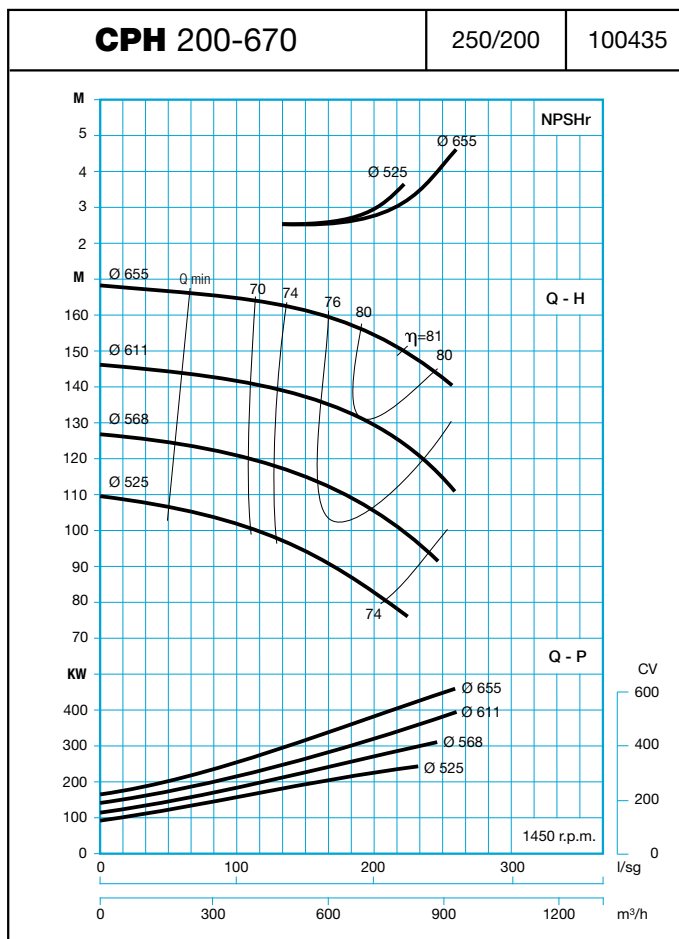
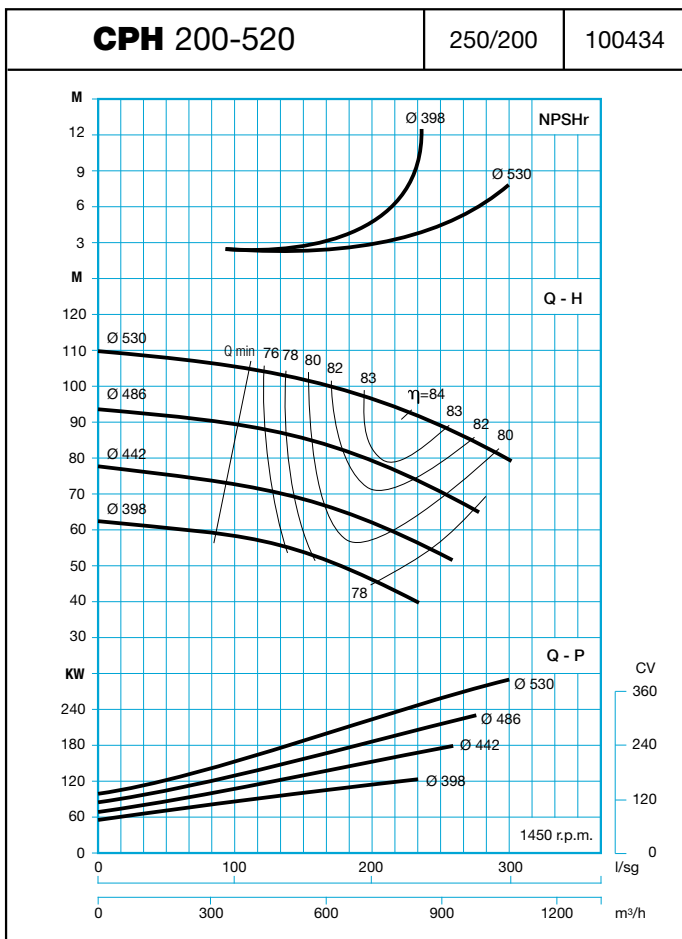
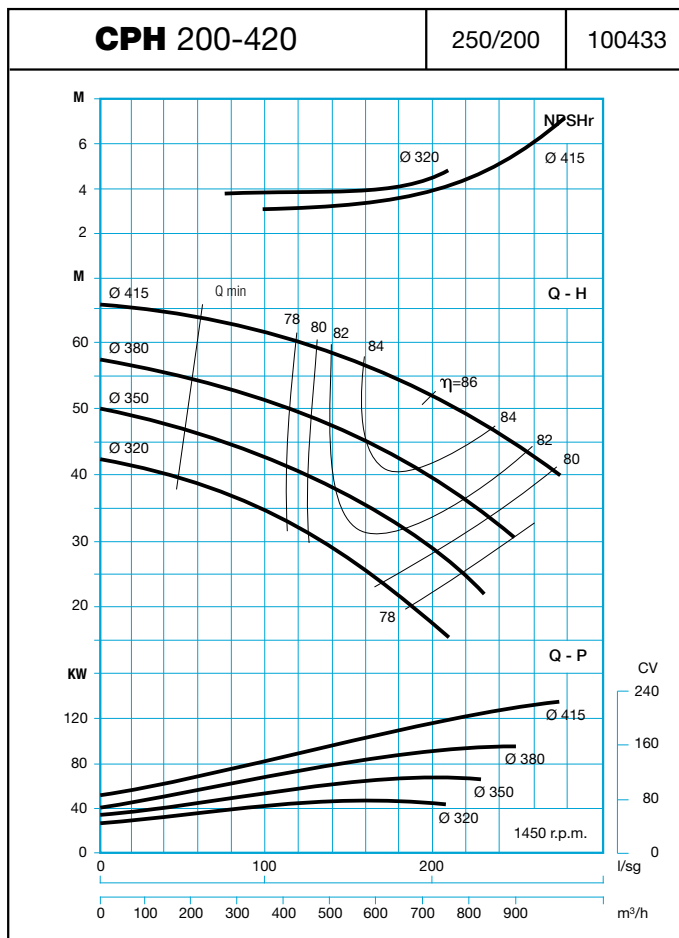
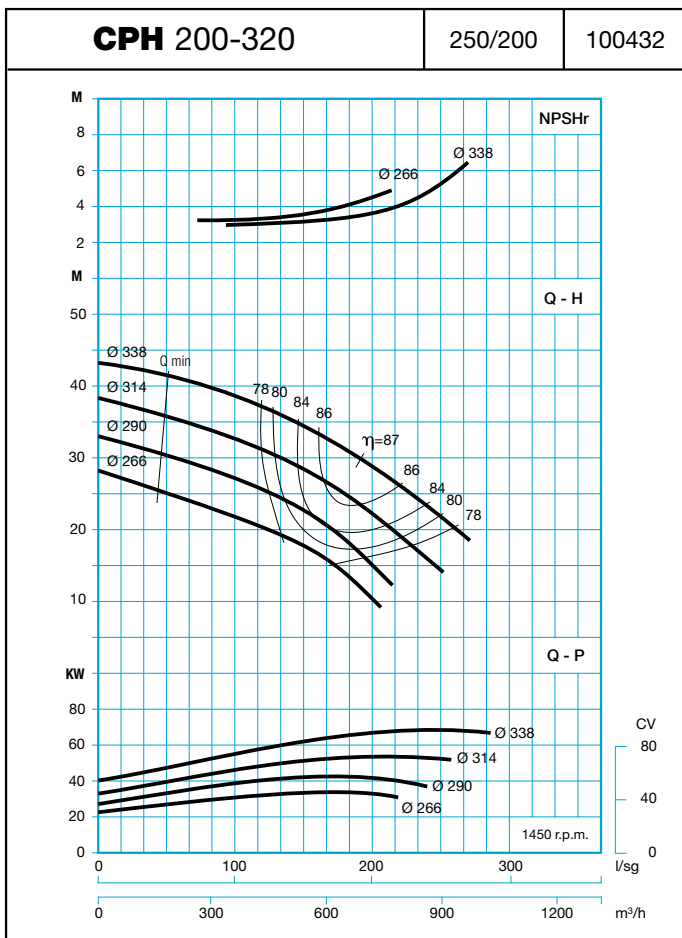

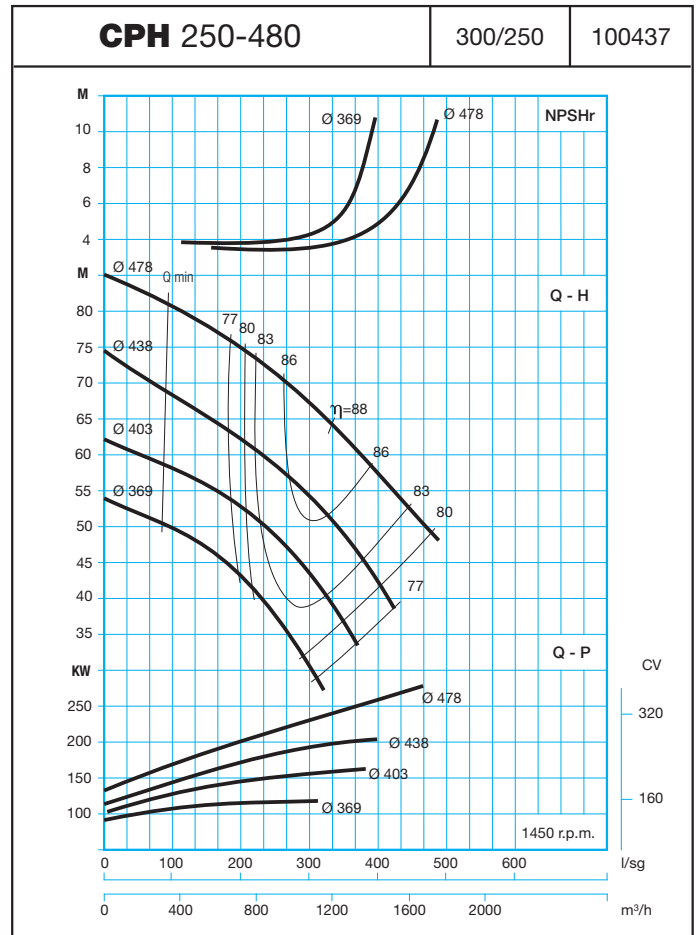
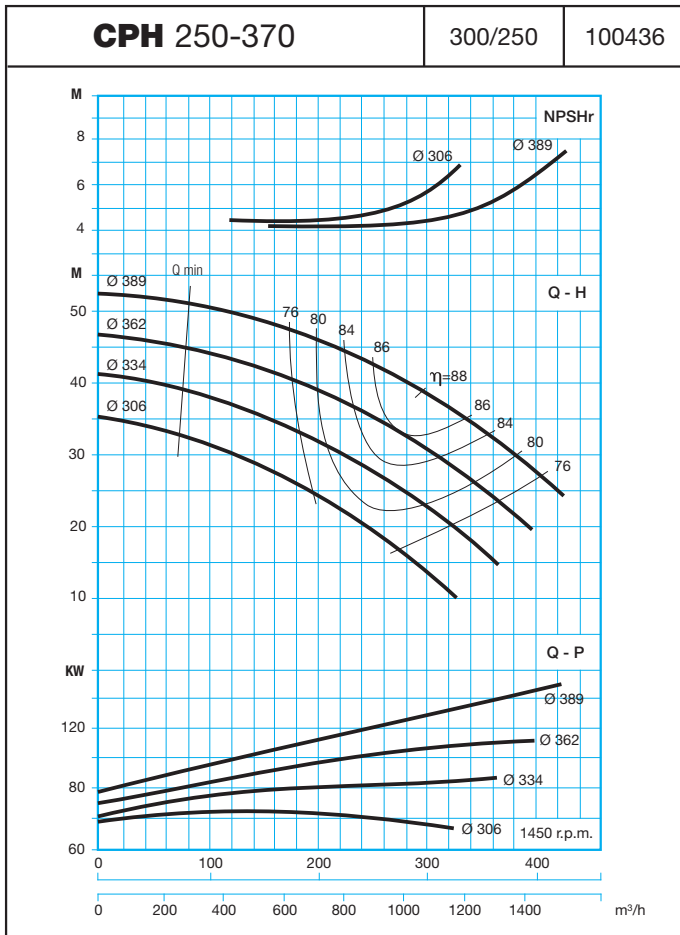

50Hz / 1450 RPM

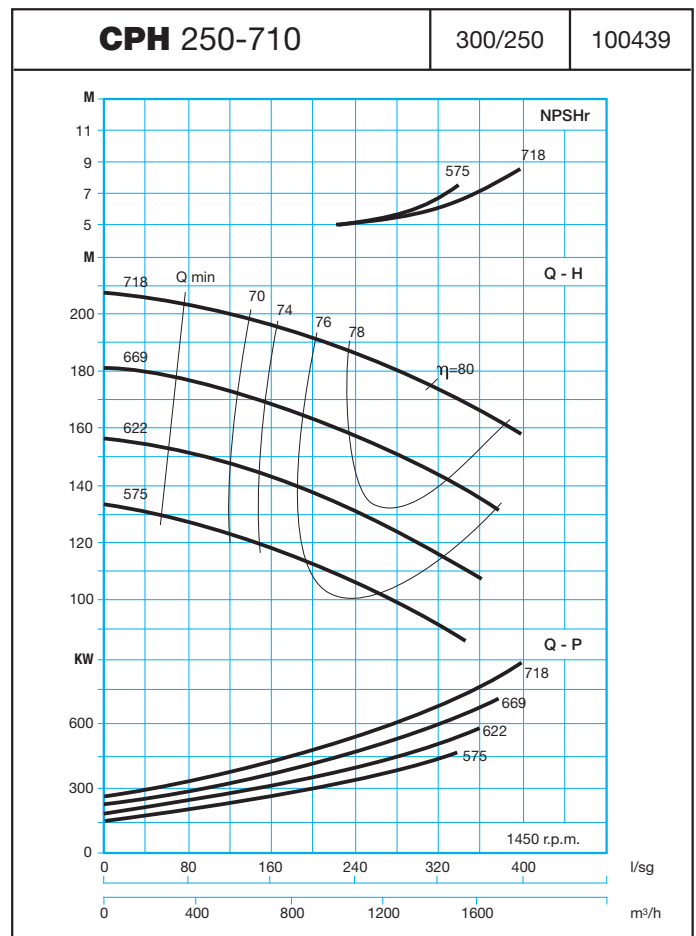
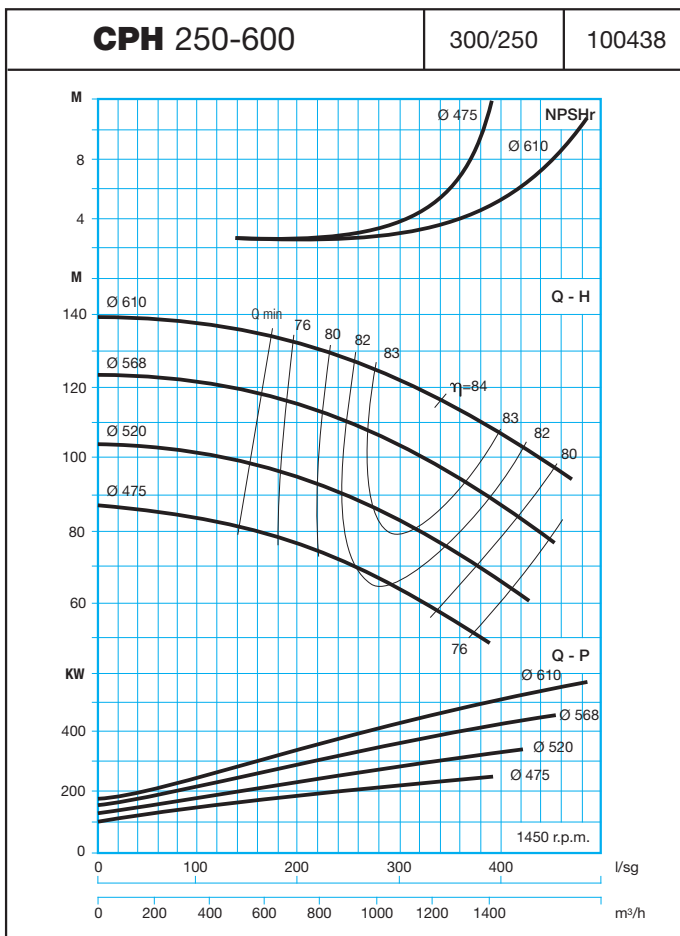

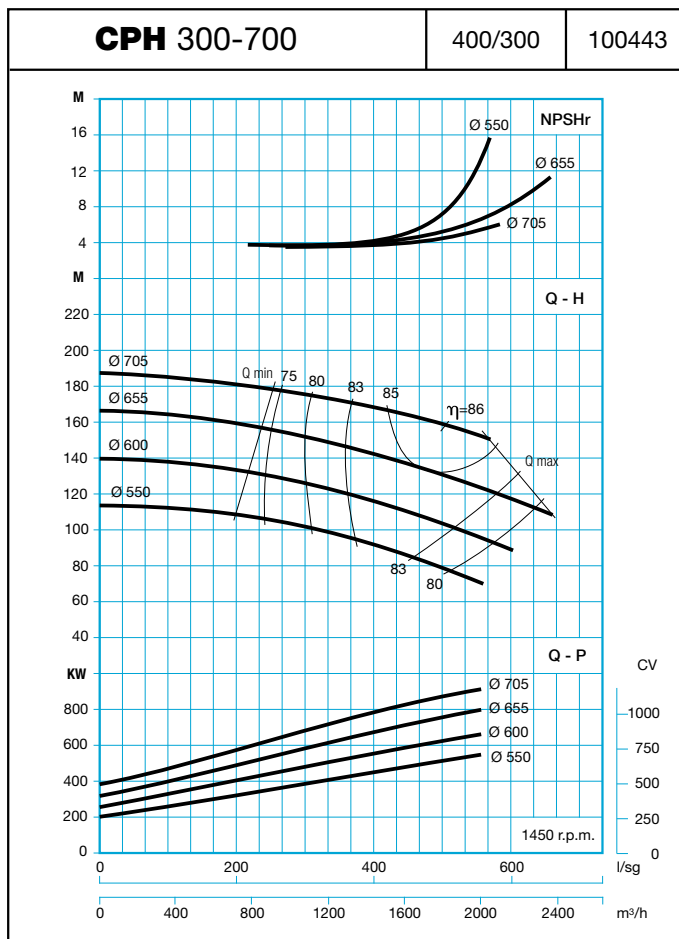
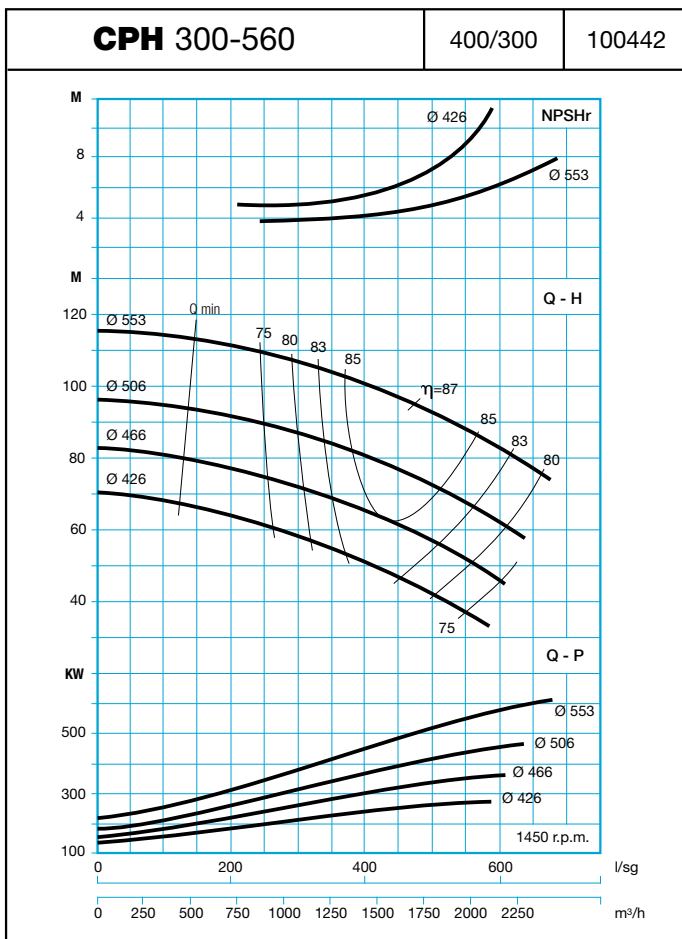
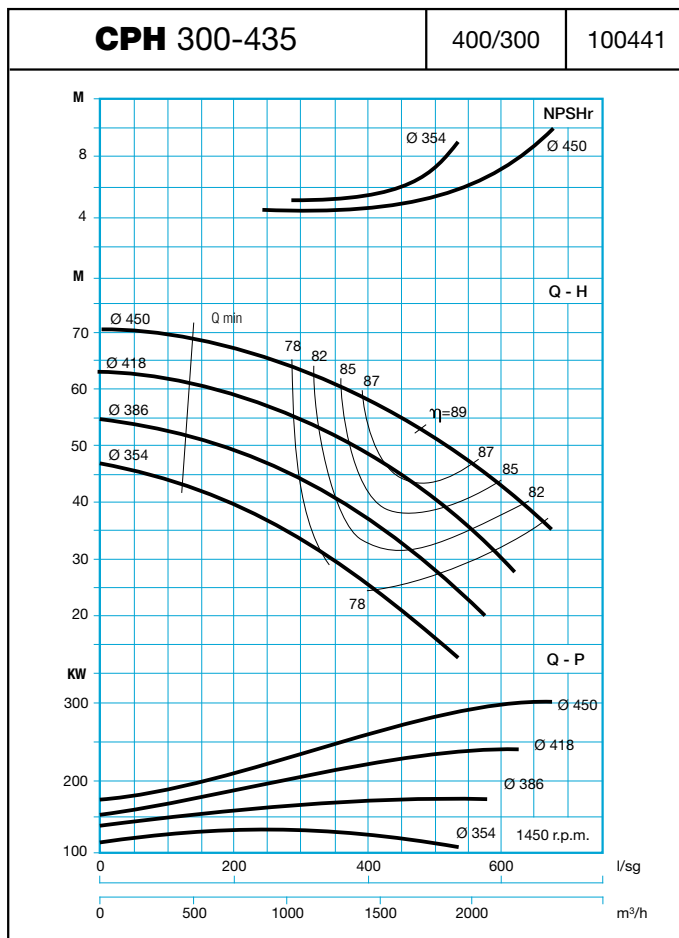
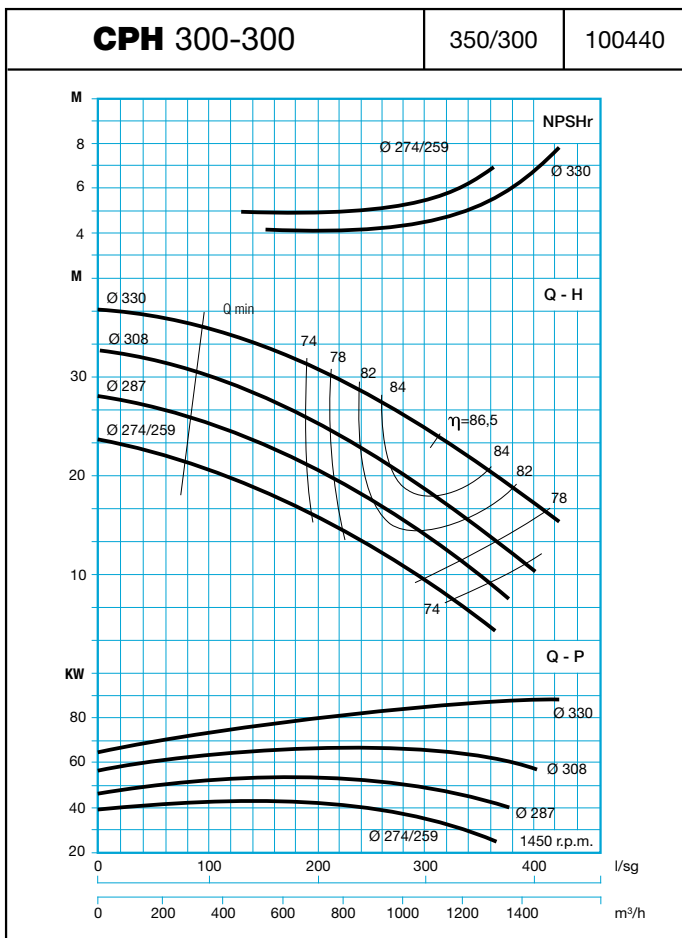

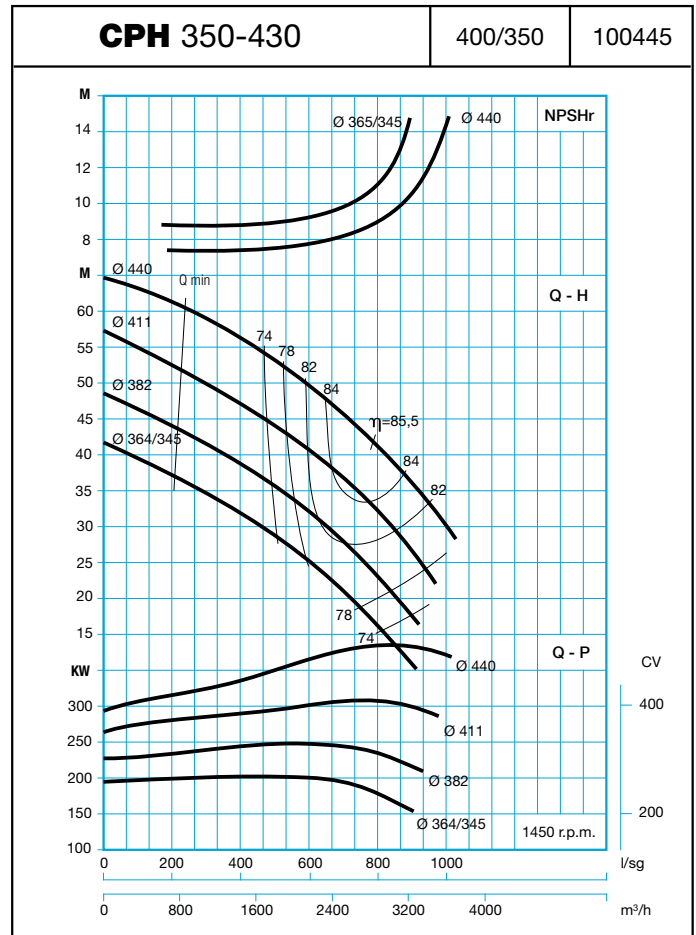
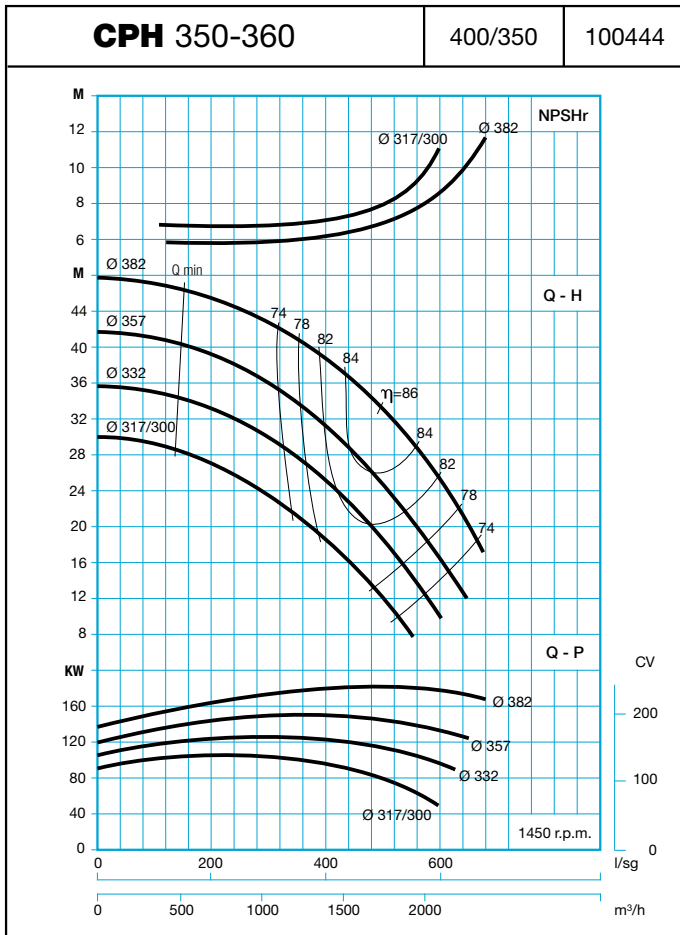

50Hz / 1450 RPM

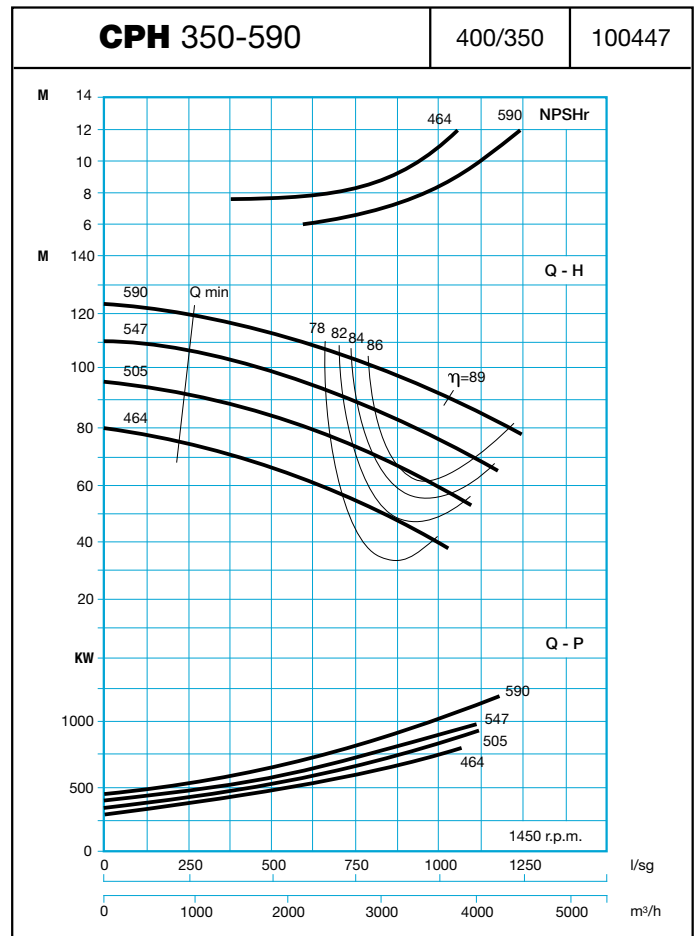
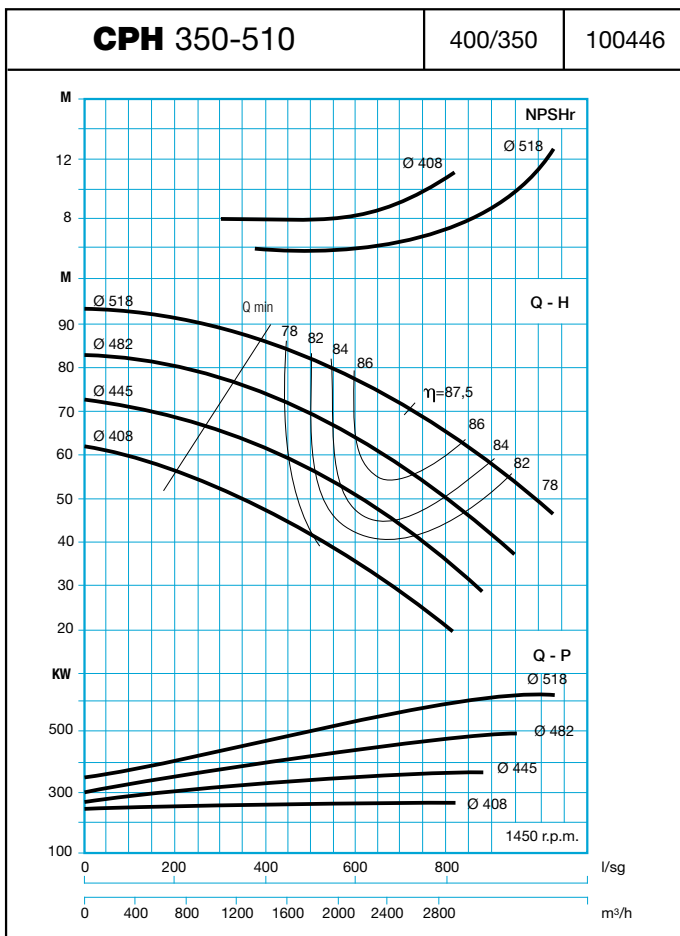

50Hz / 1450 RPM

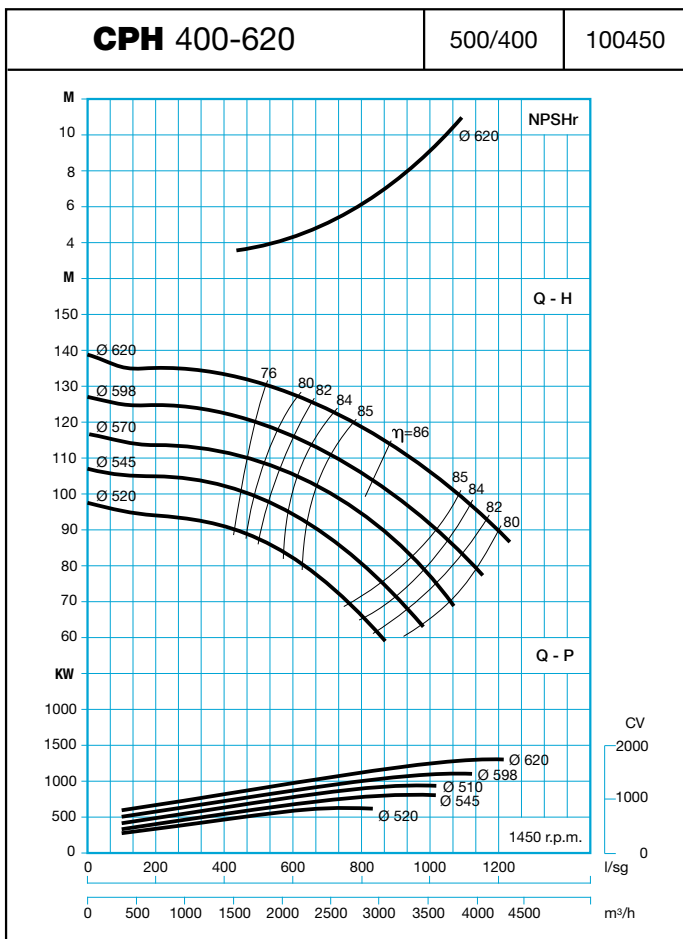
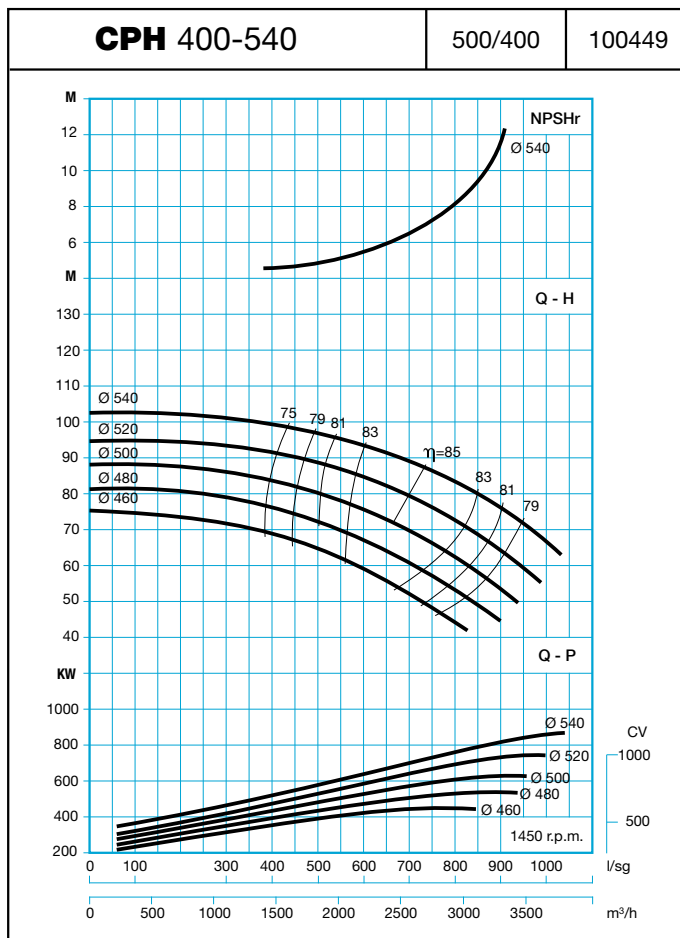
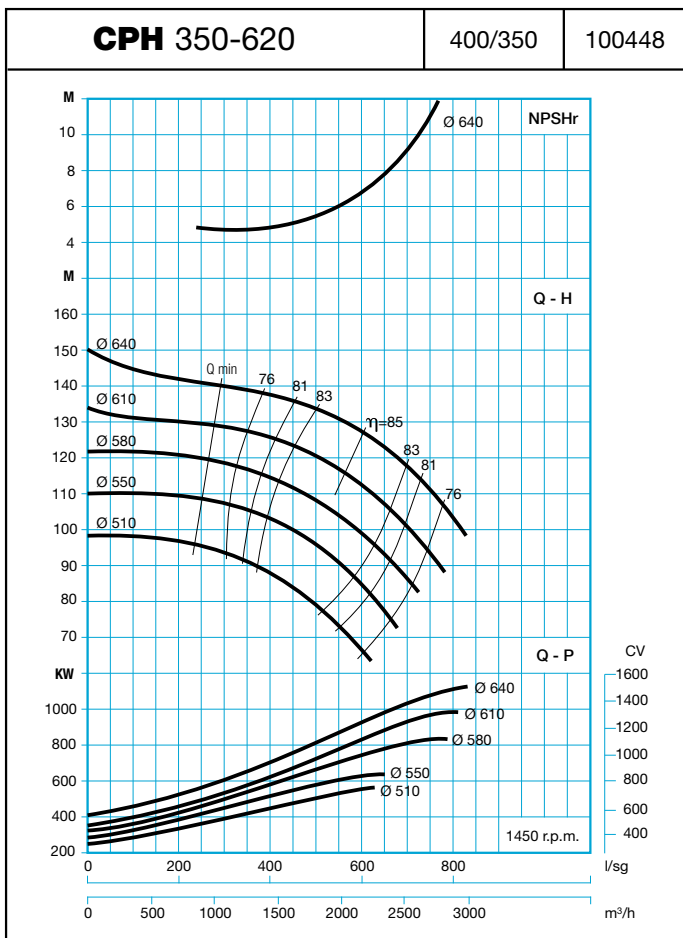

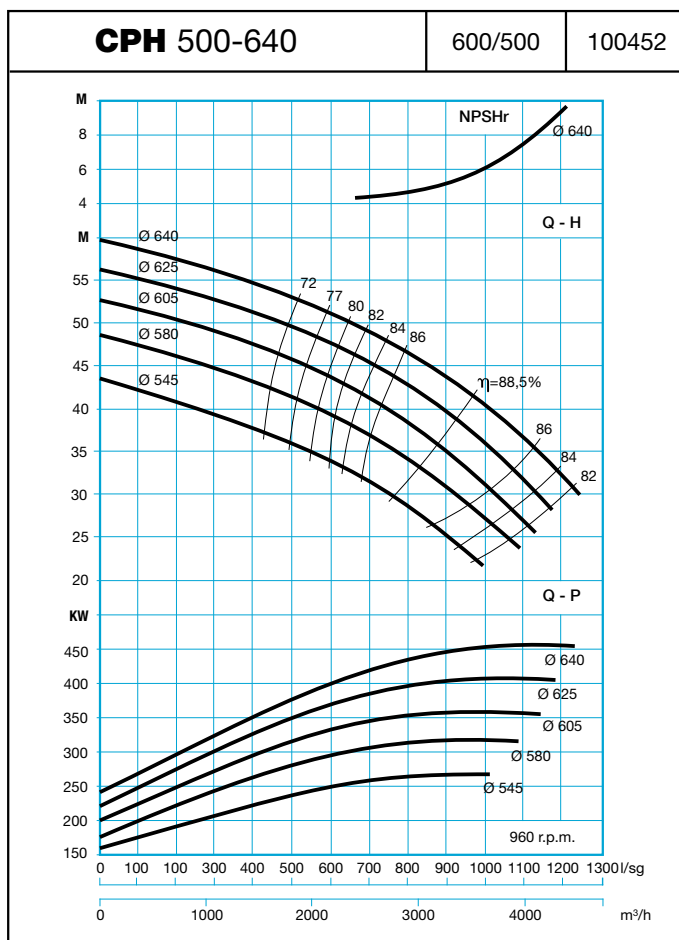
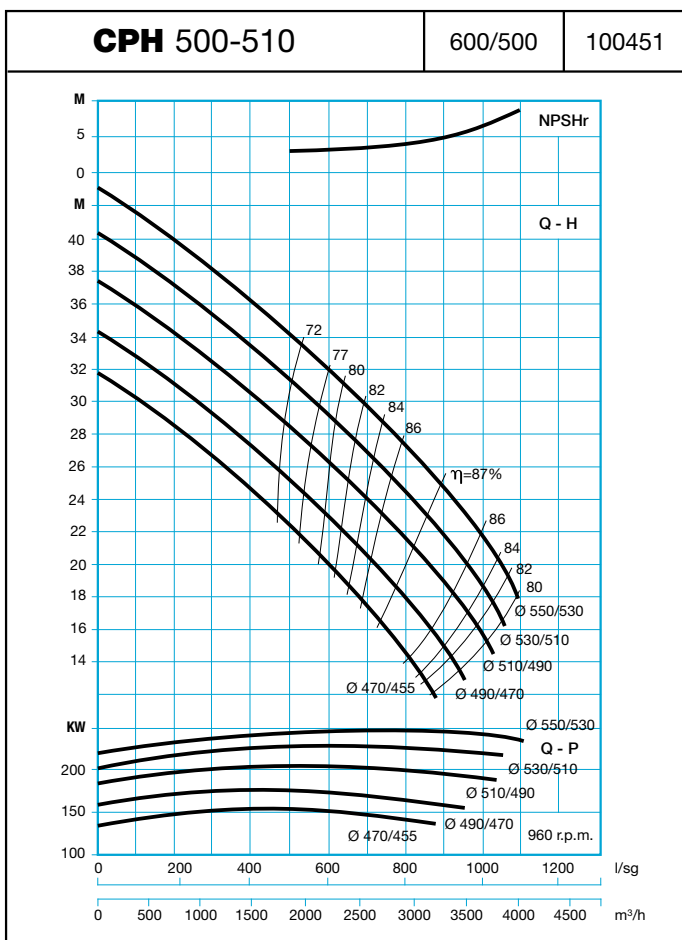

50Hz / 960 RPM

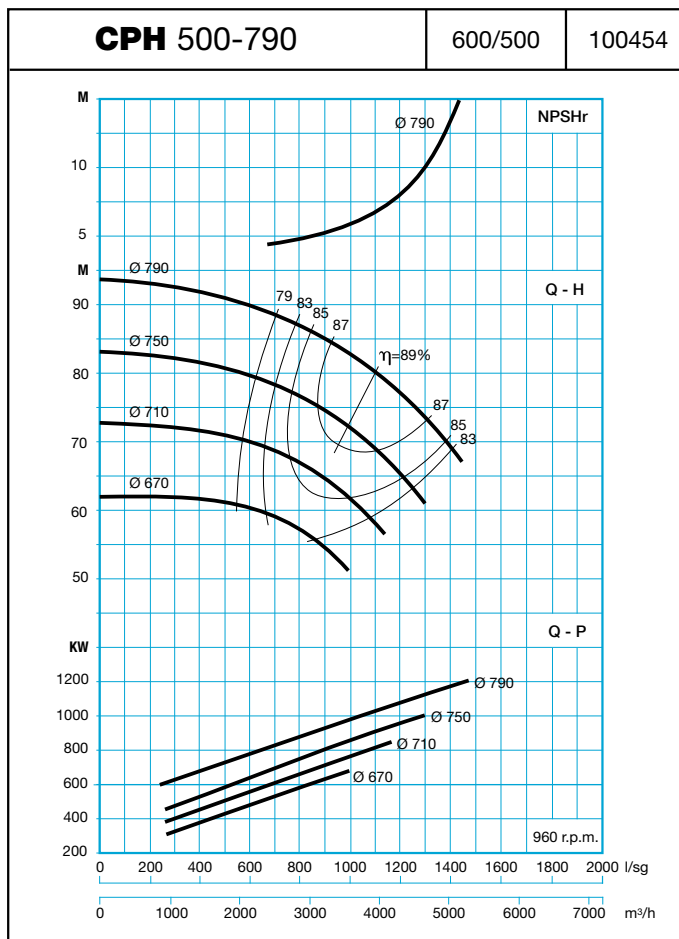
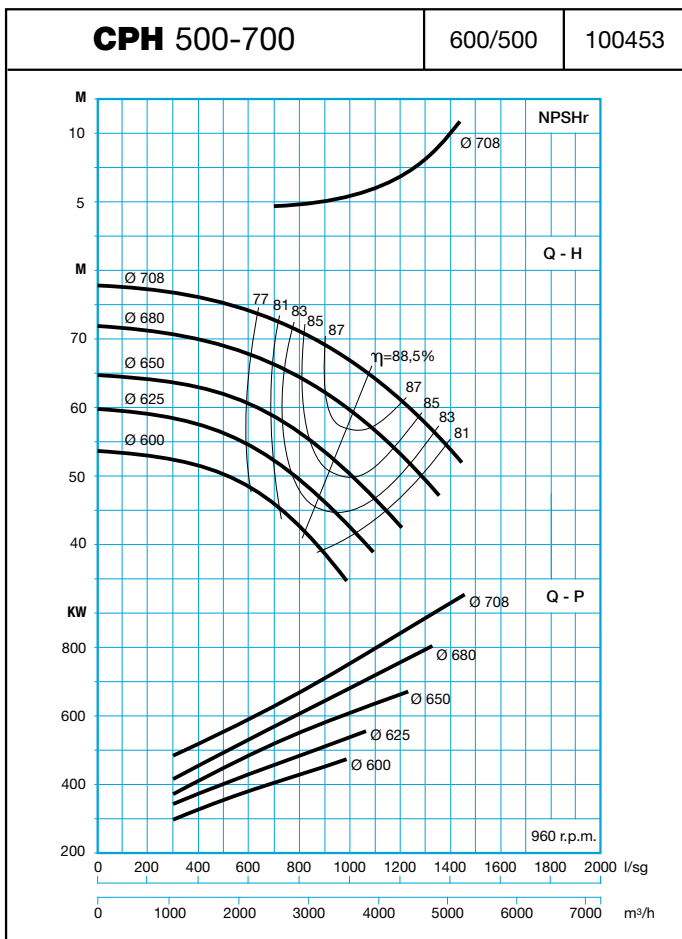

50Hz / 960 RPM

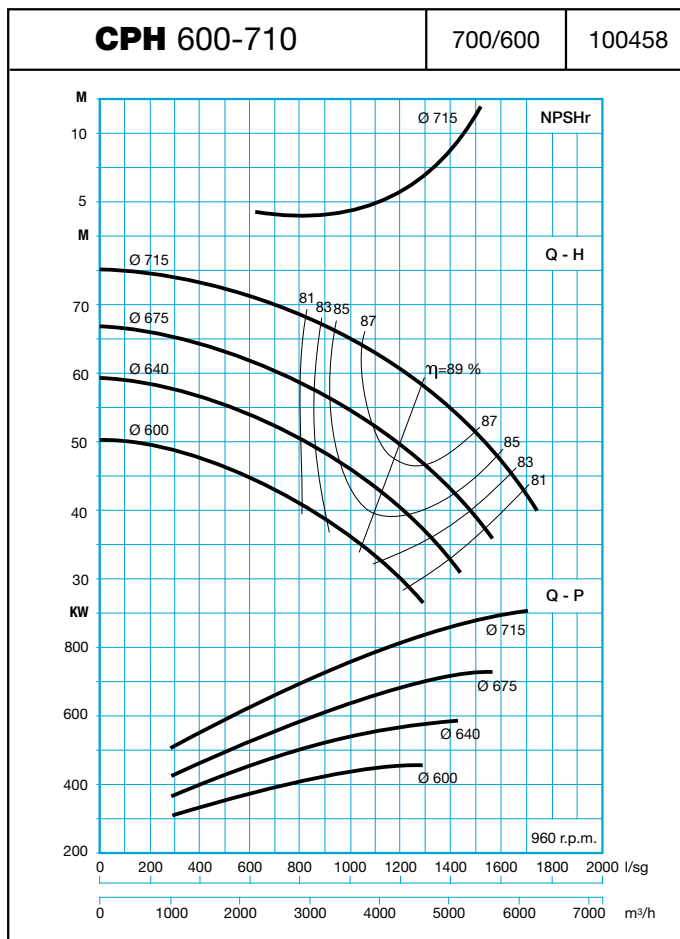
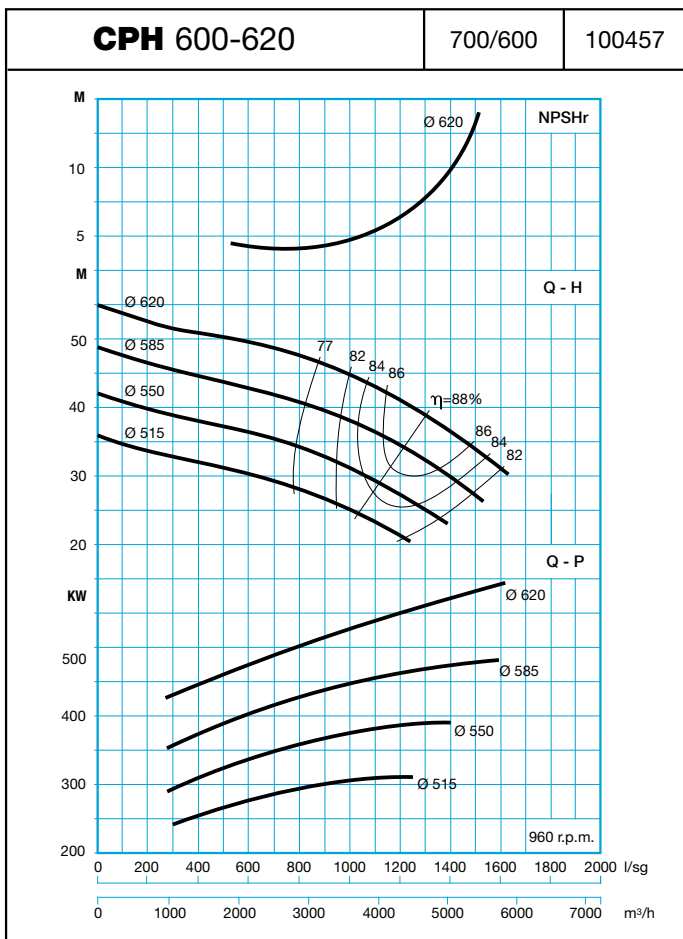
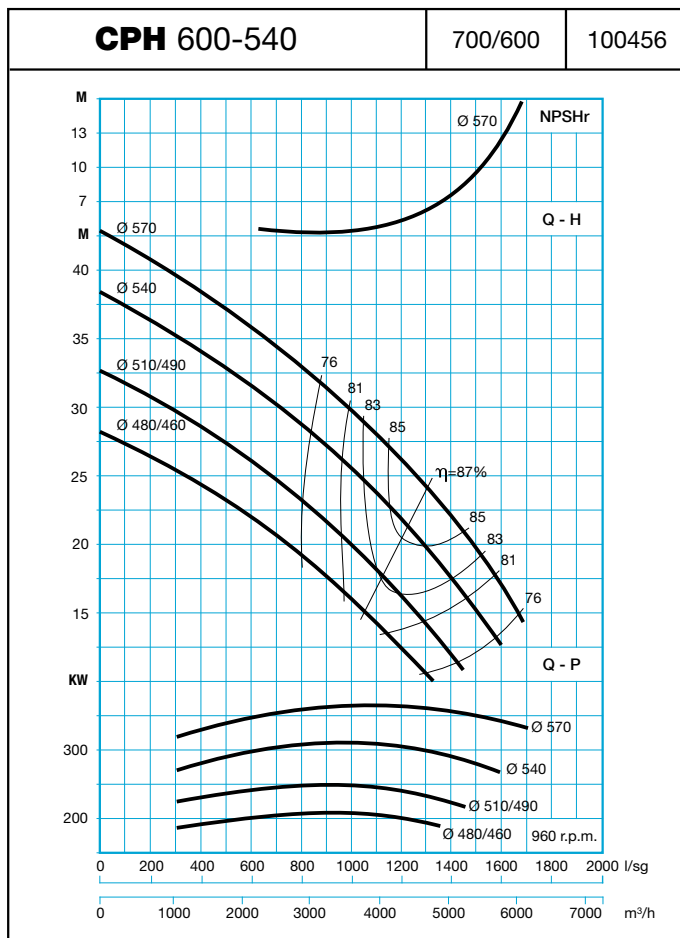
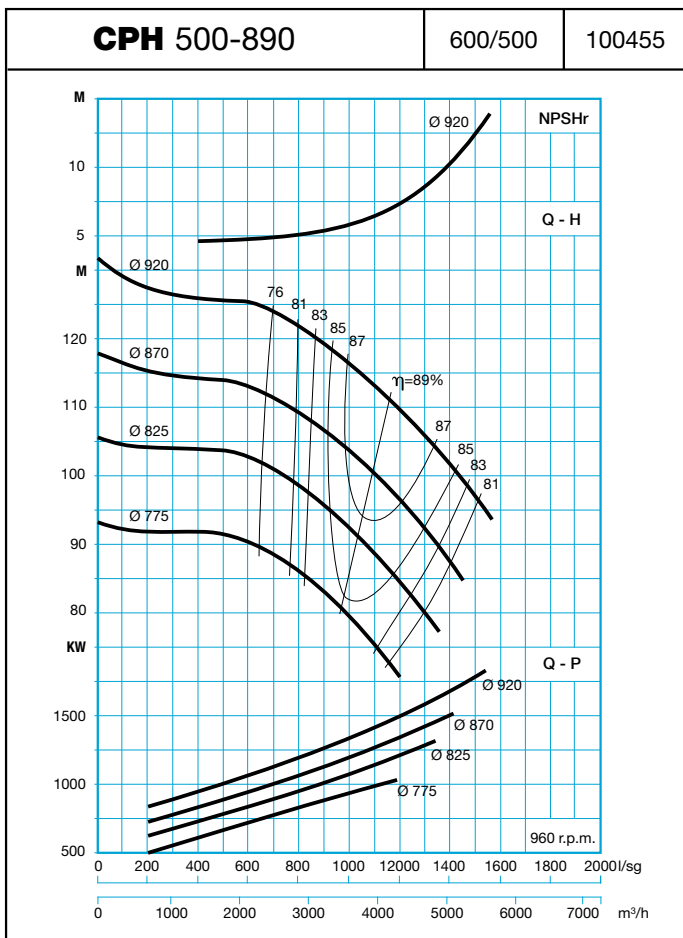

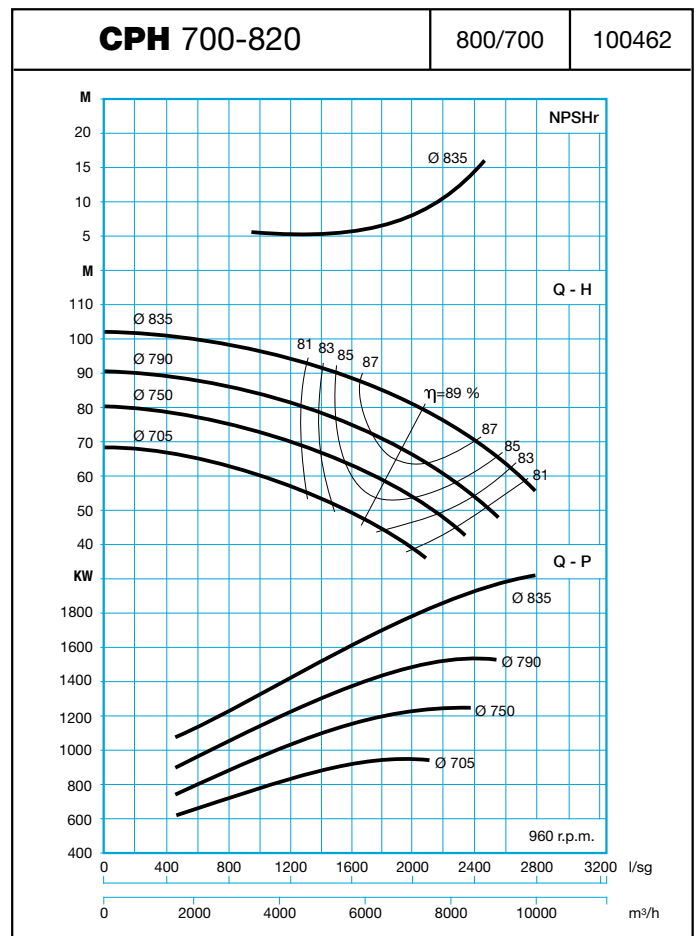
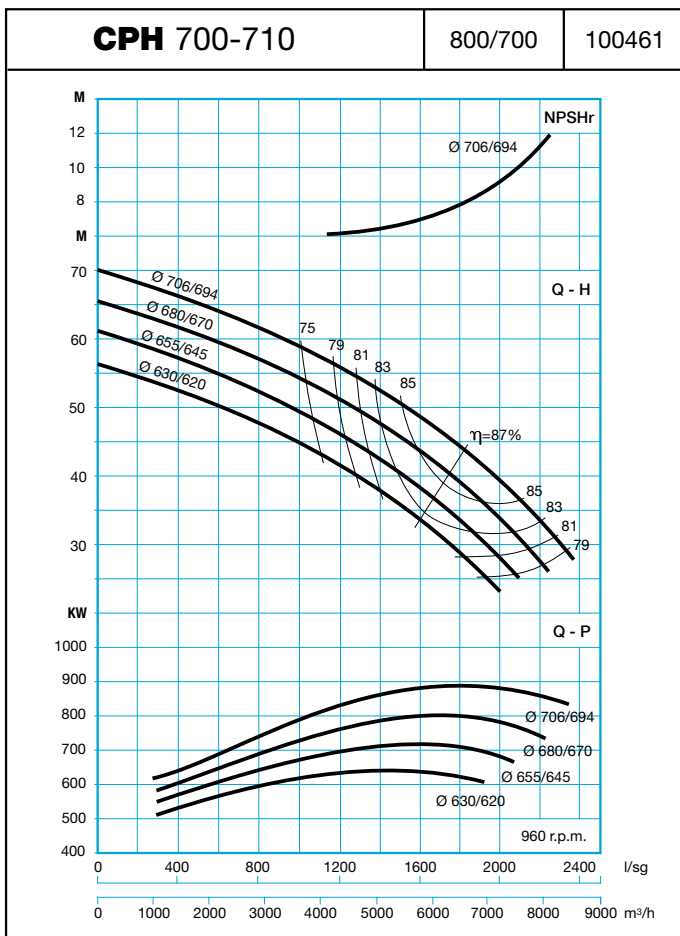
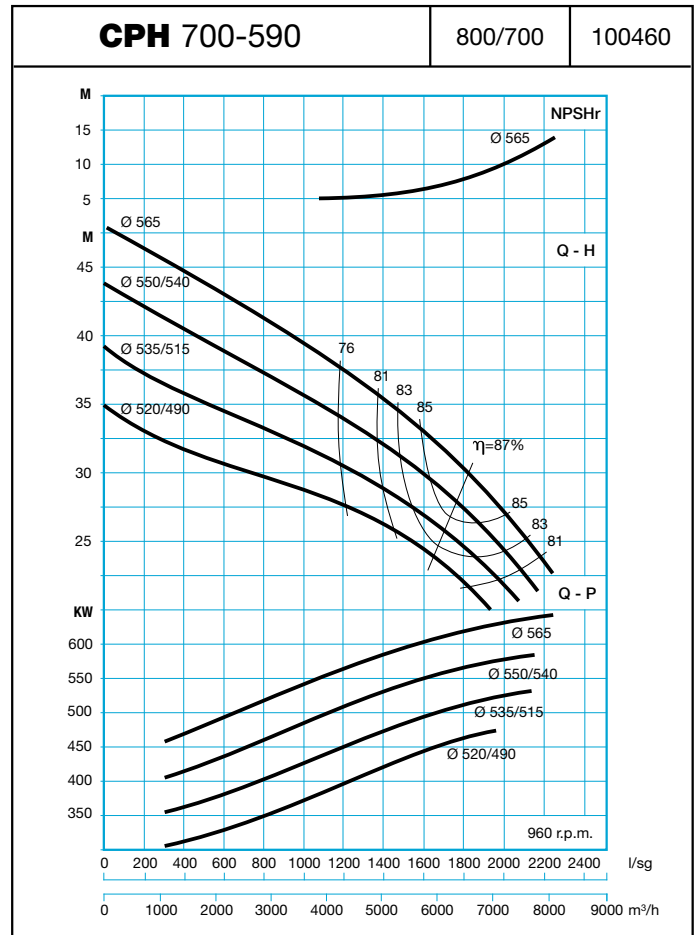
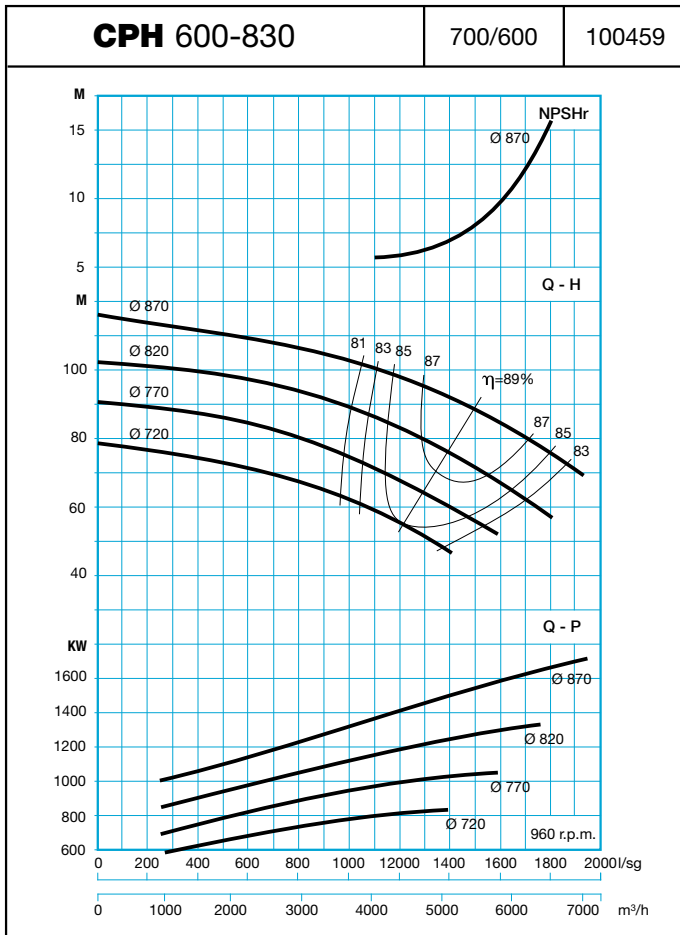

50Hz / 960 RPM

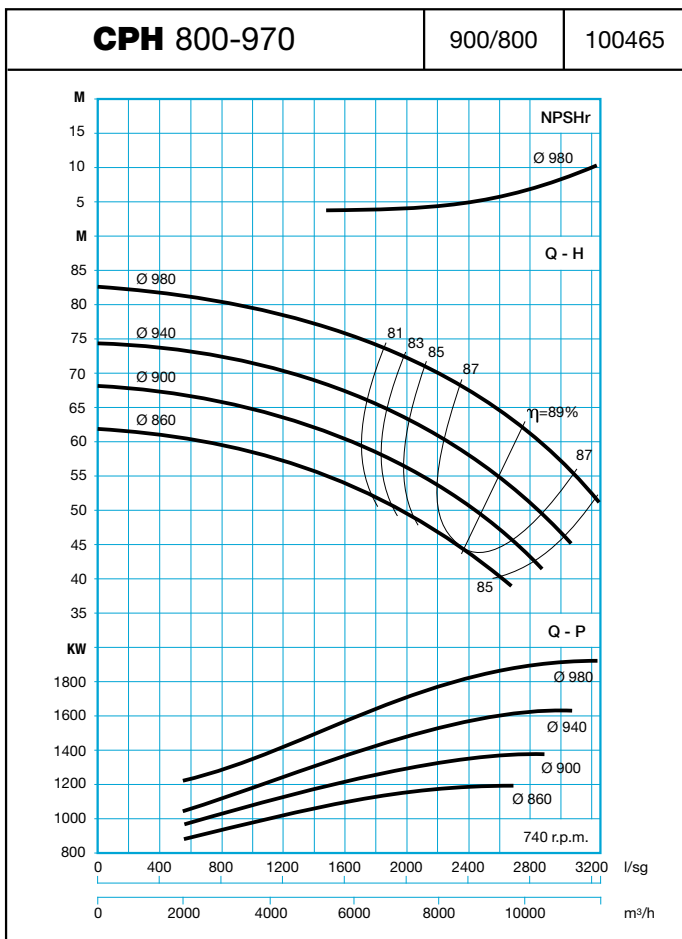
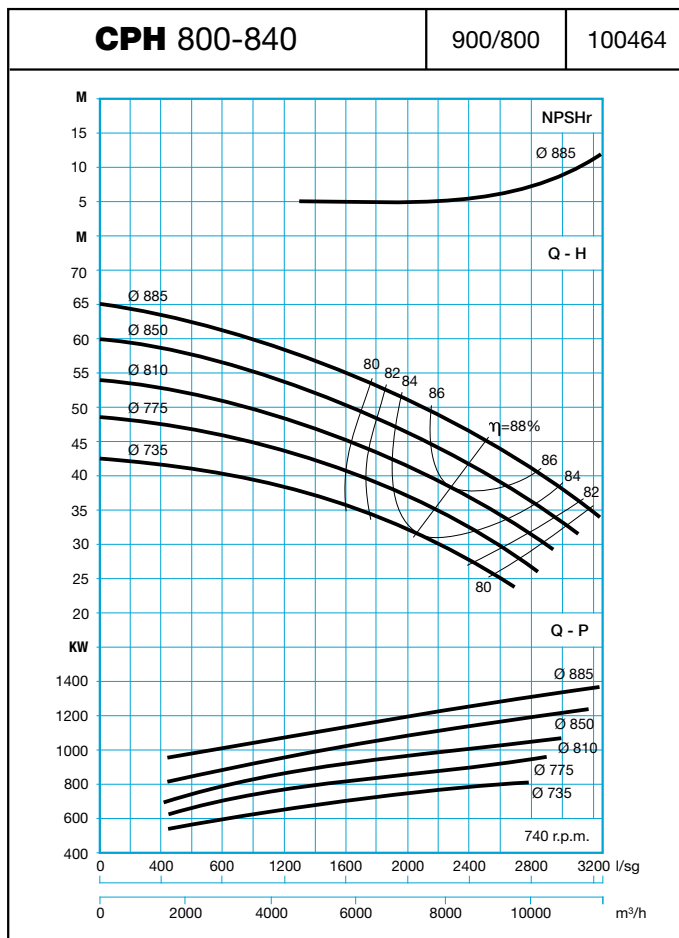
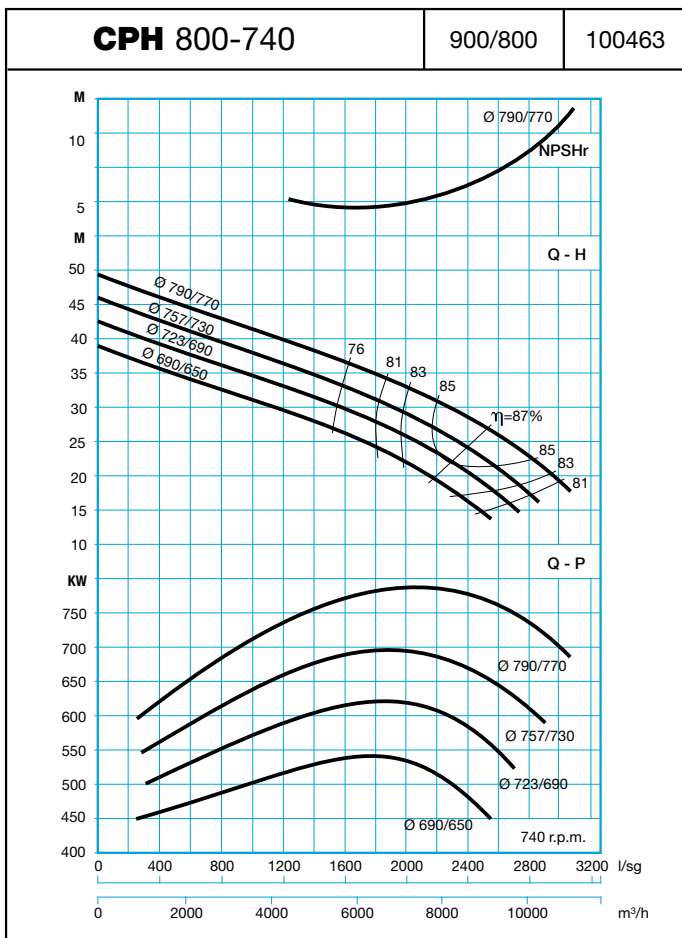

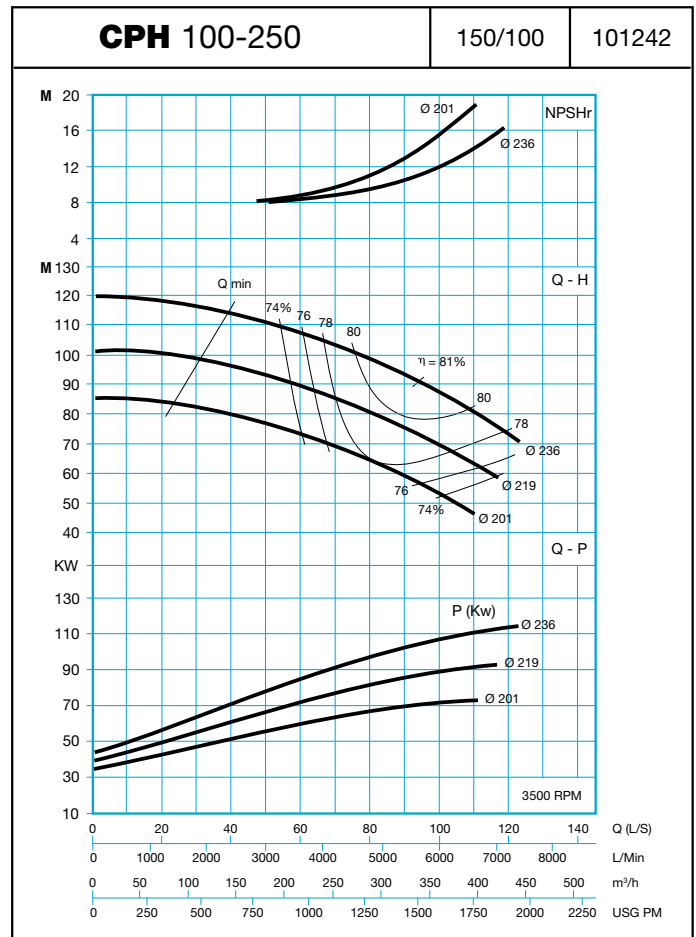
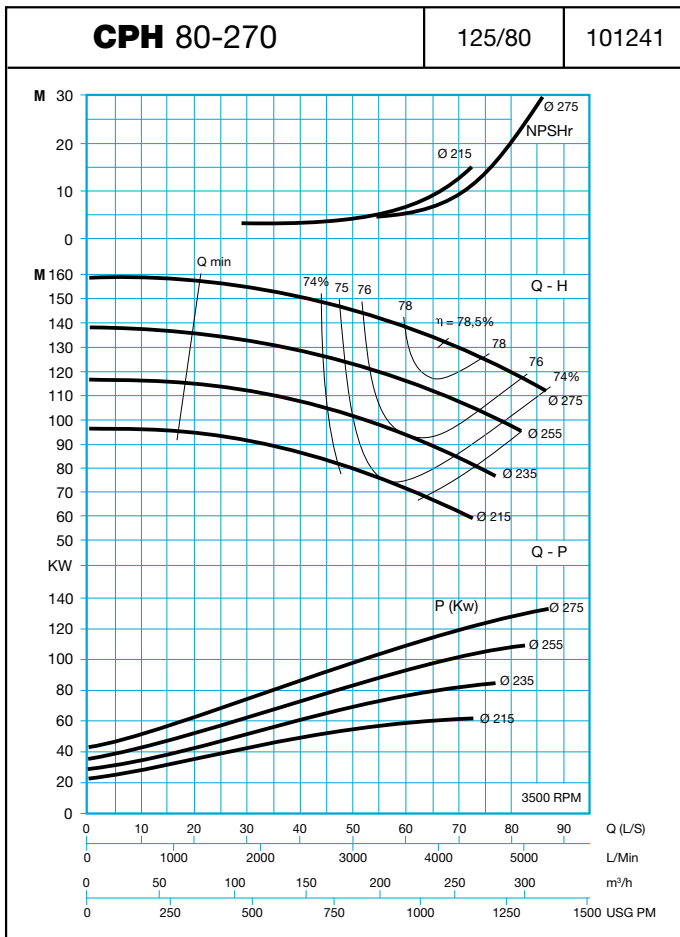
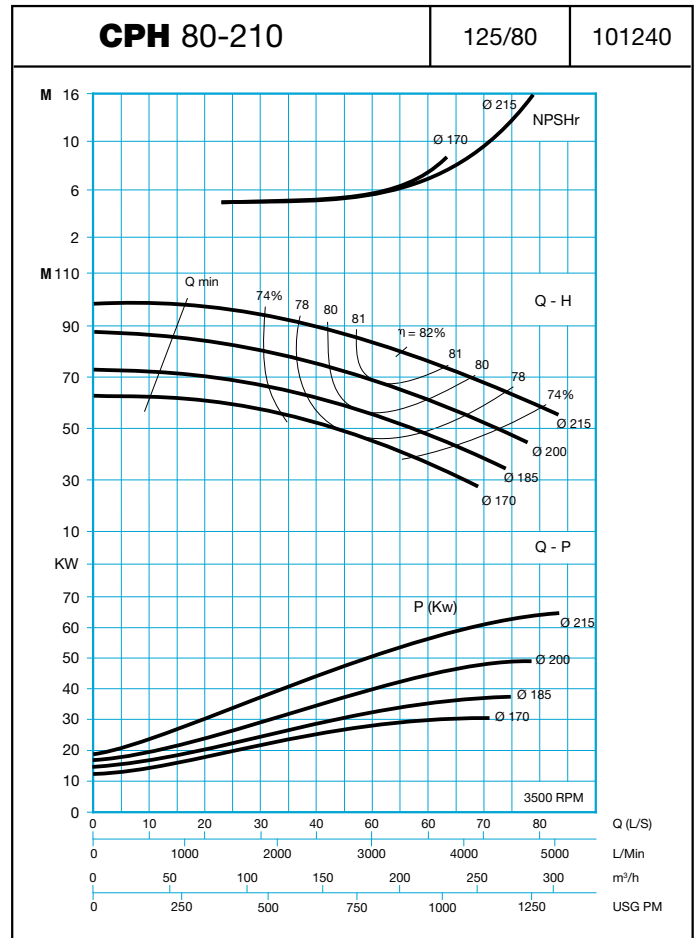
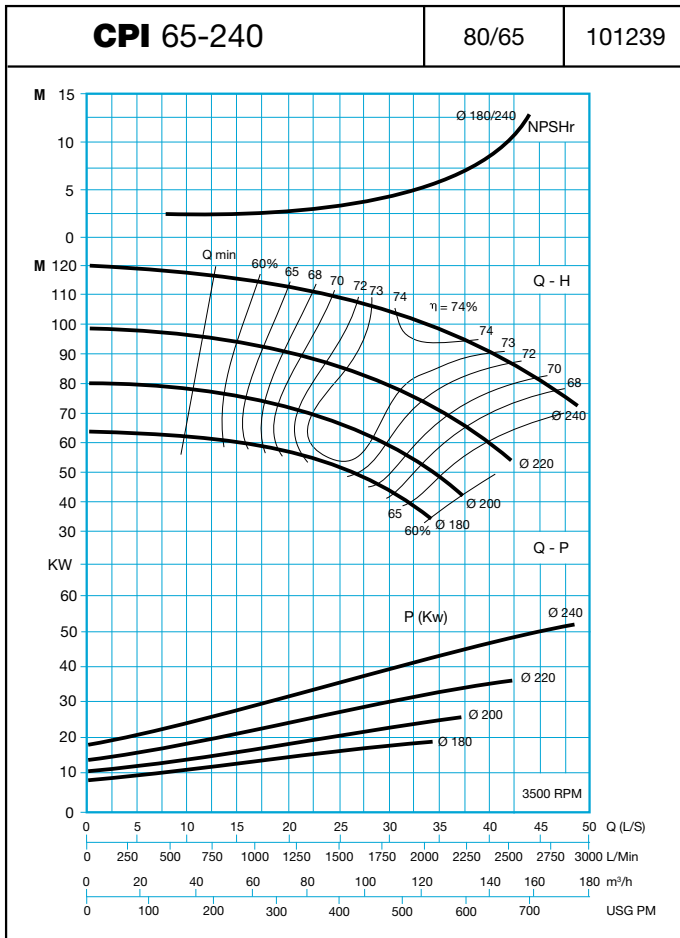

60Hz / 3500 RPM

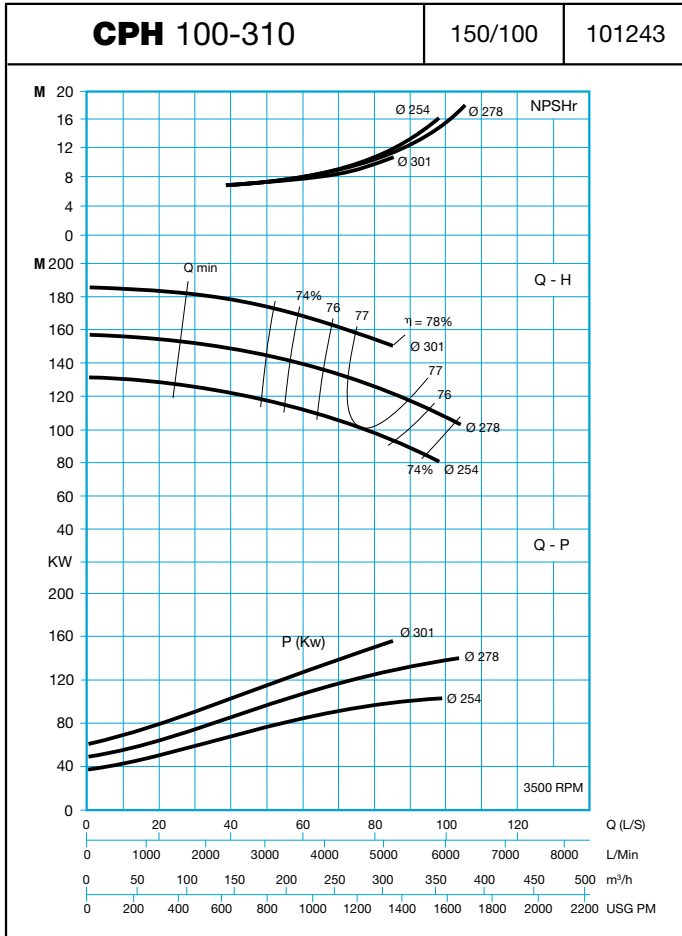

3500 RPM / 1750 RPM

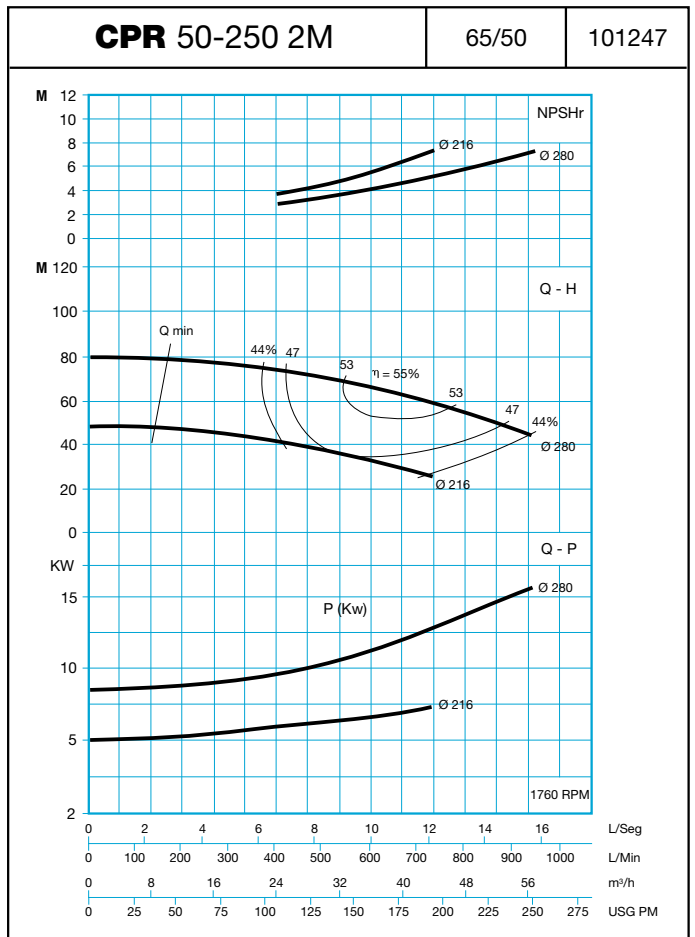
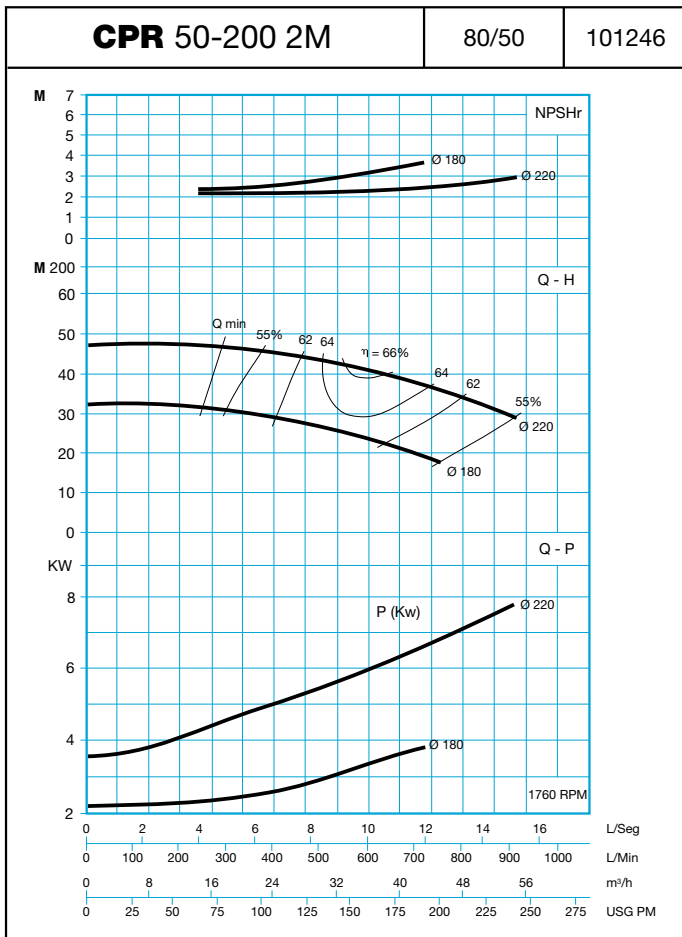

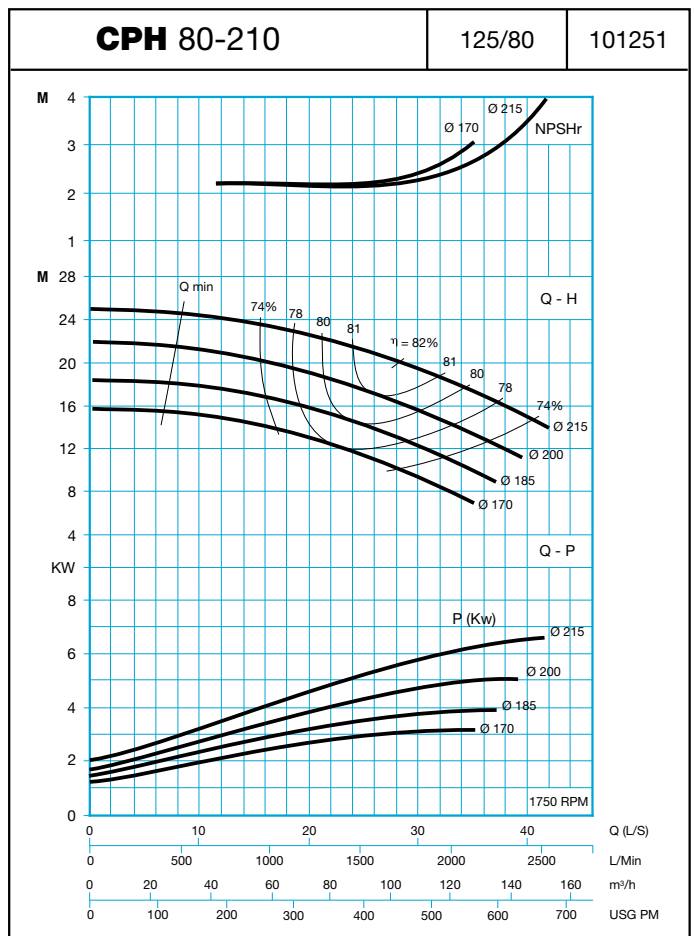
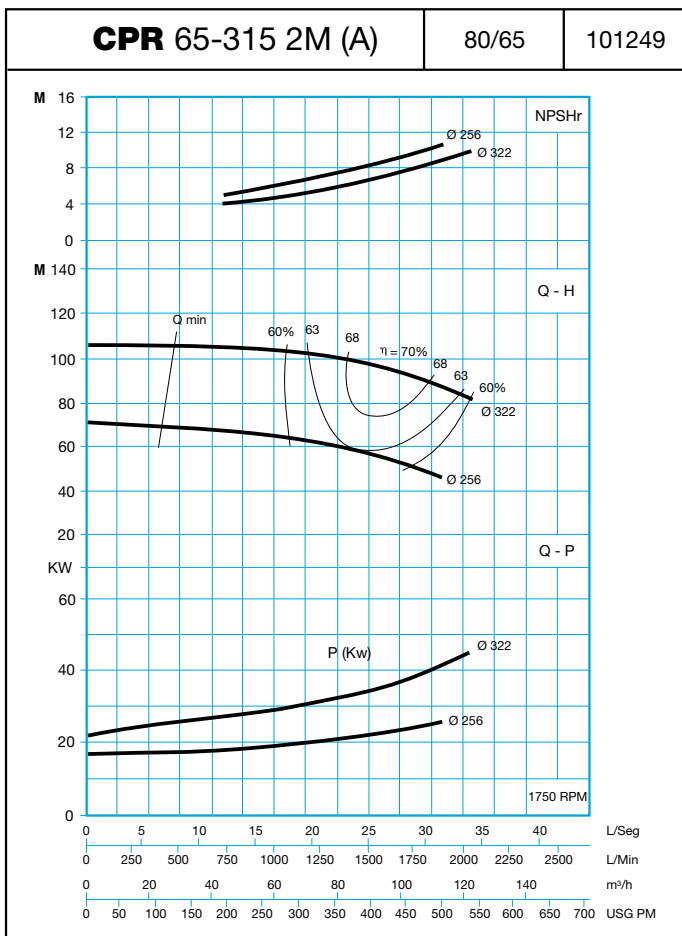
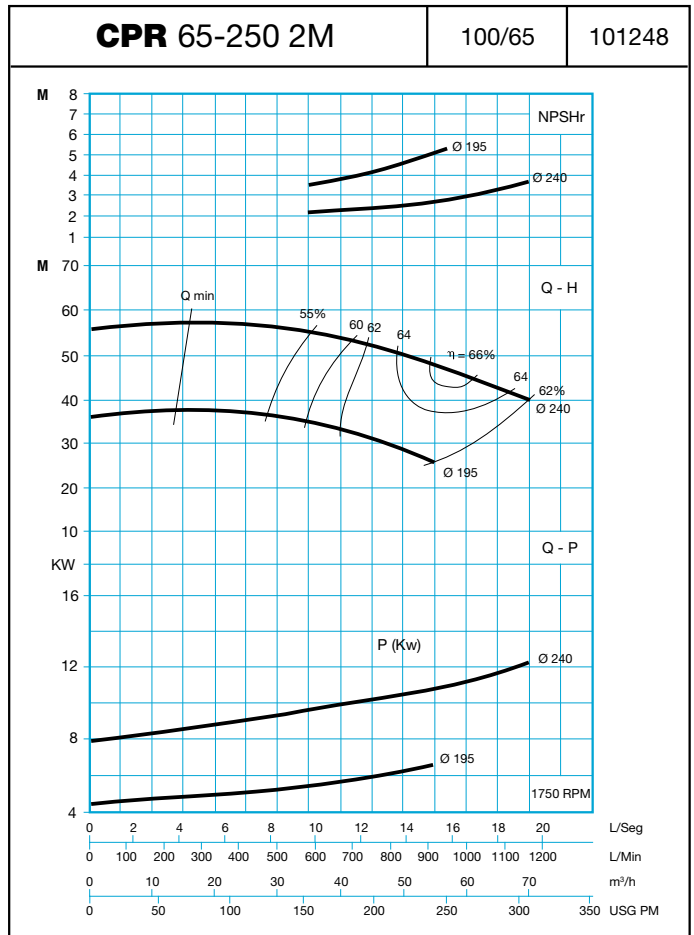
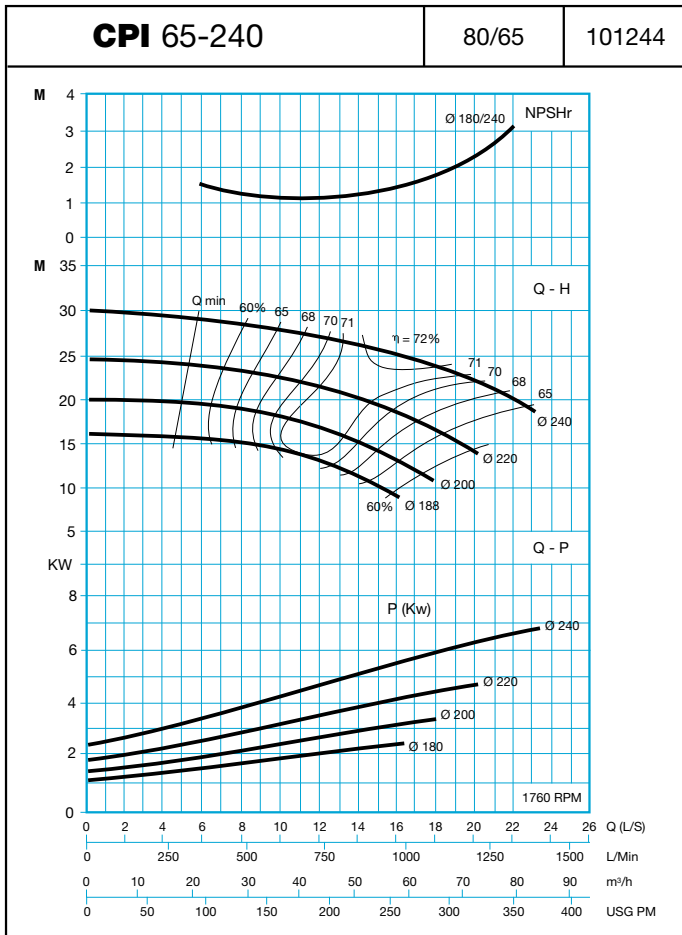

60Hz / 1750 RPM

60Hz / 1750 RPM

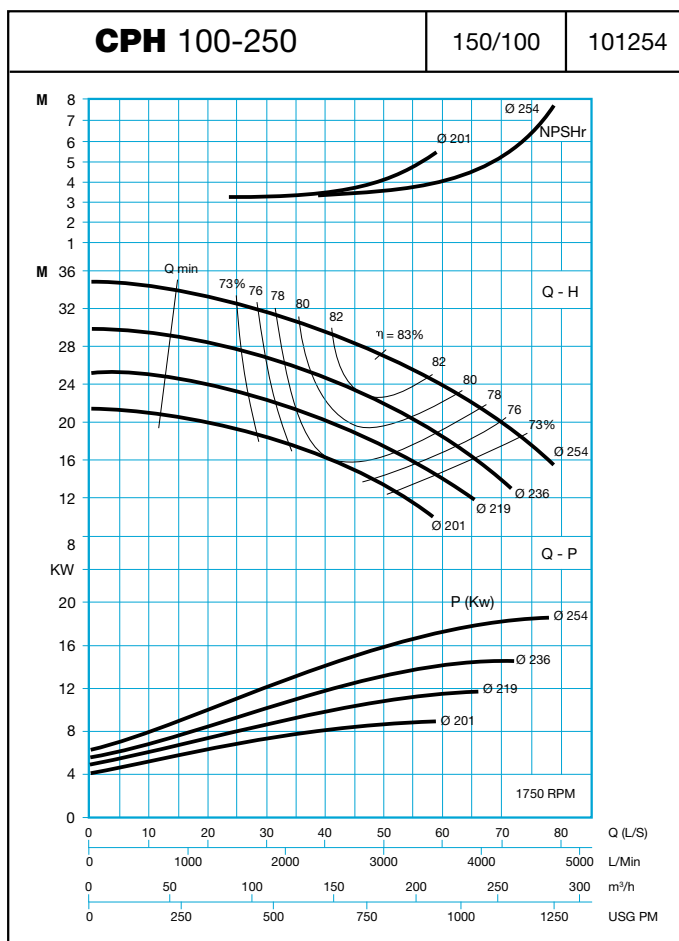
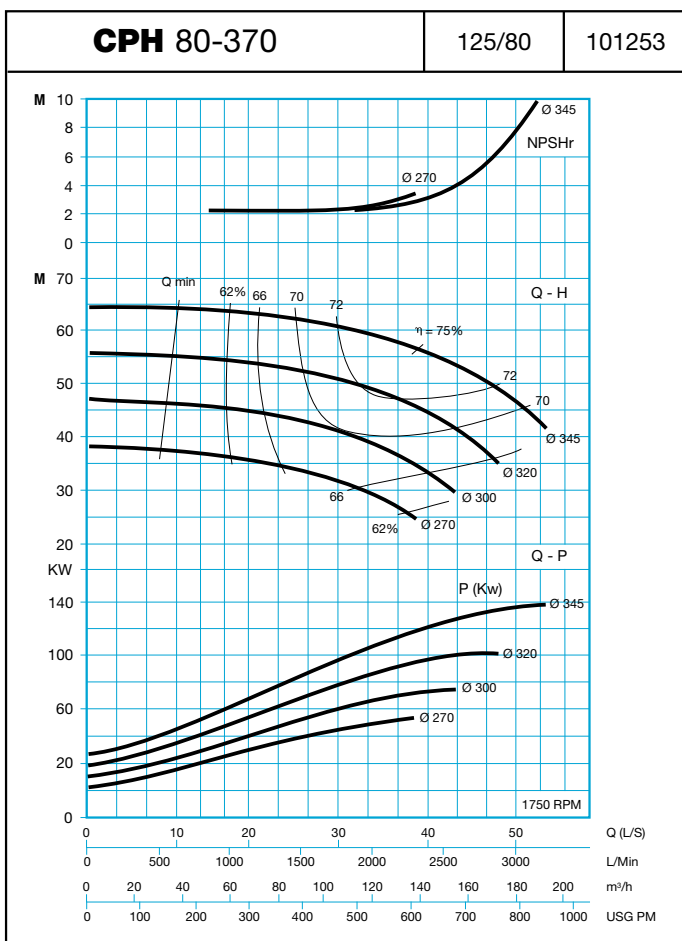
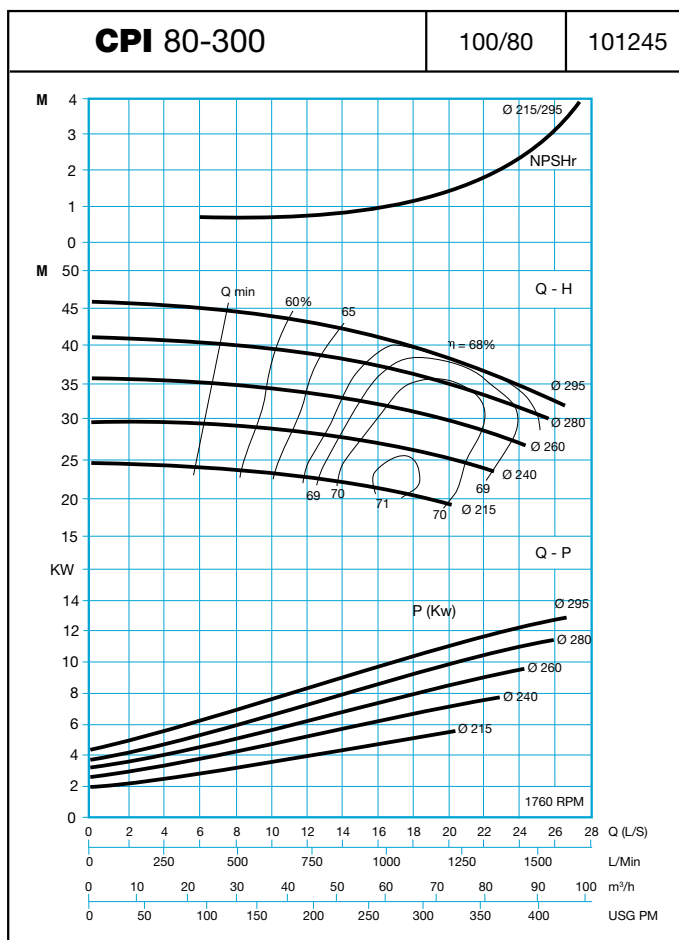
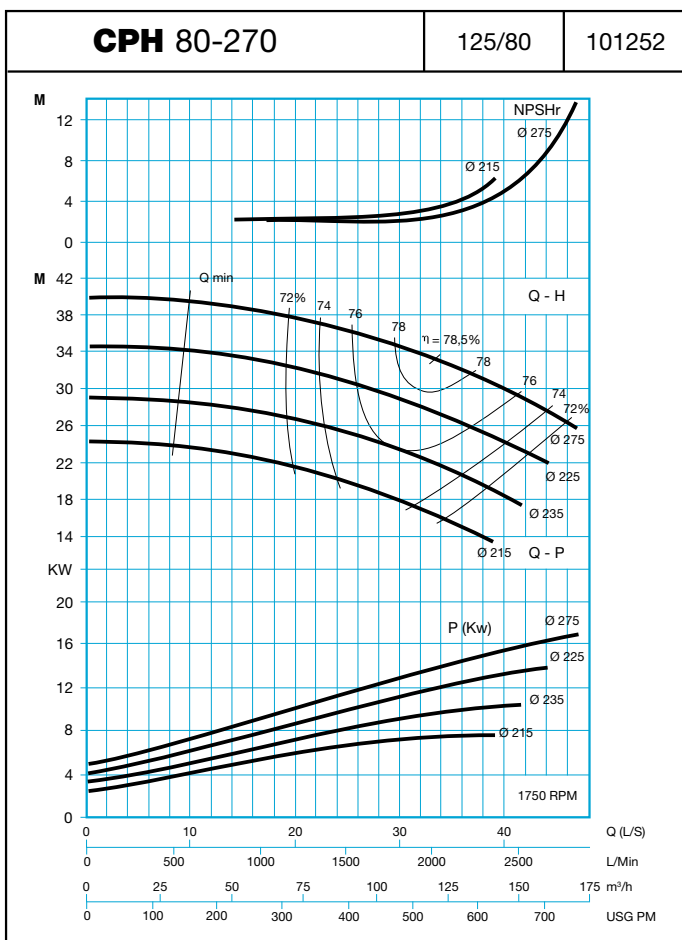

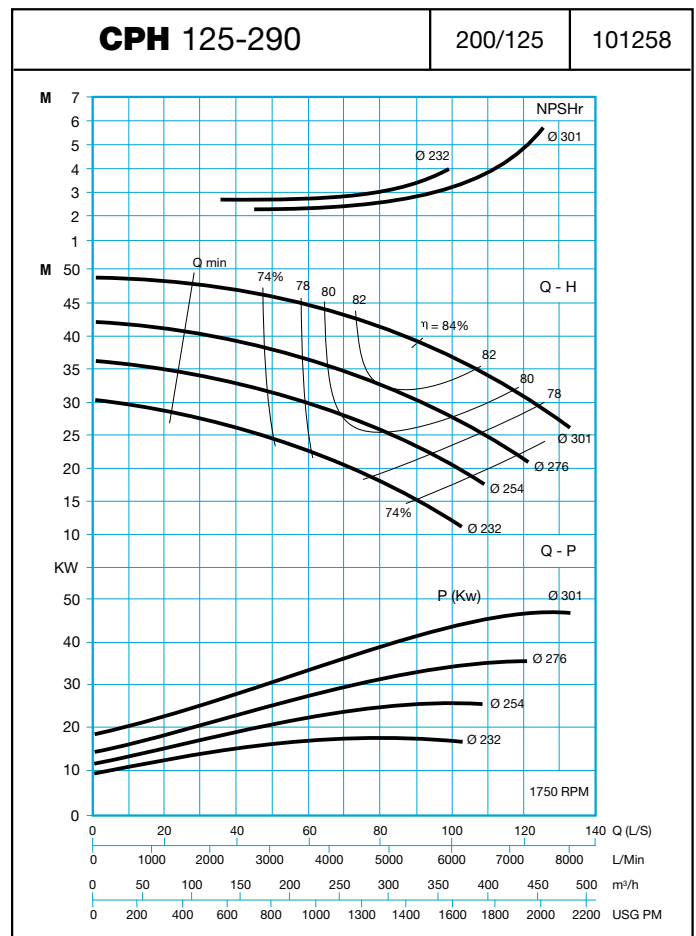
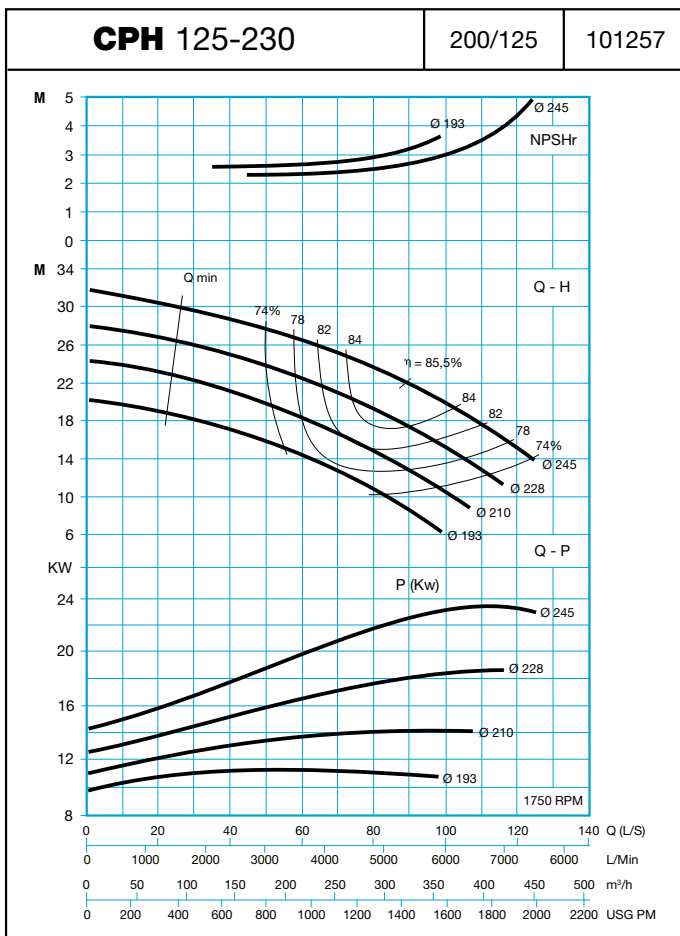
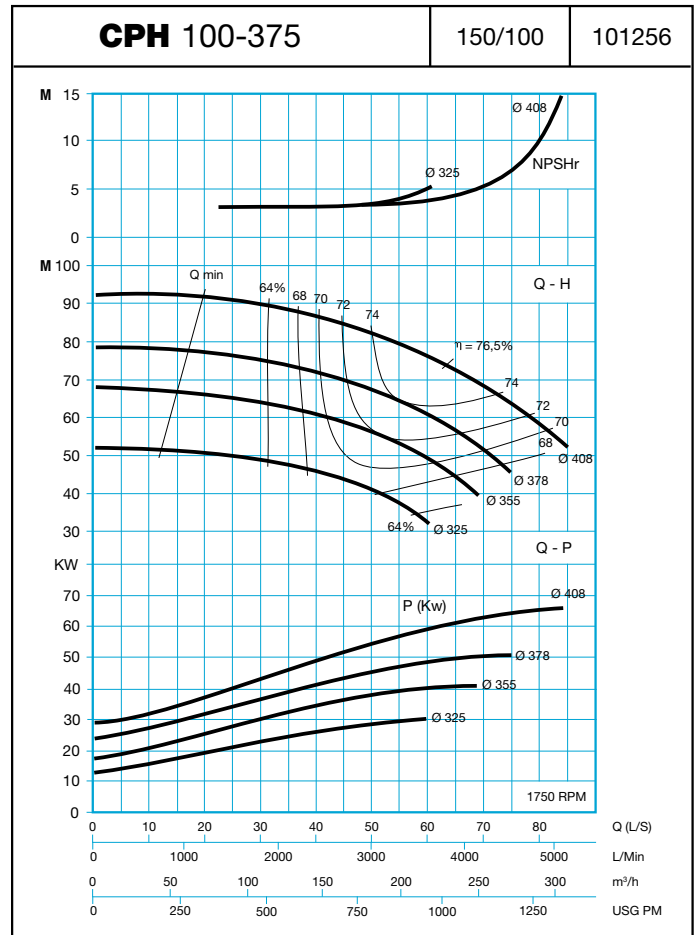
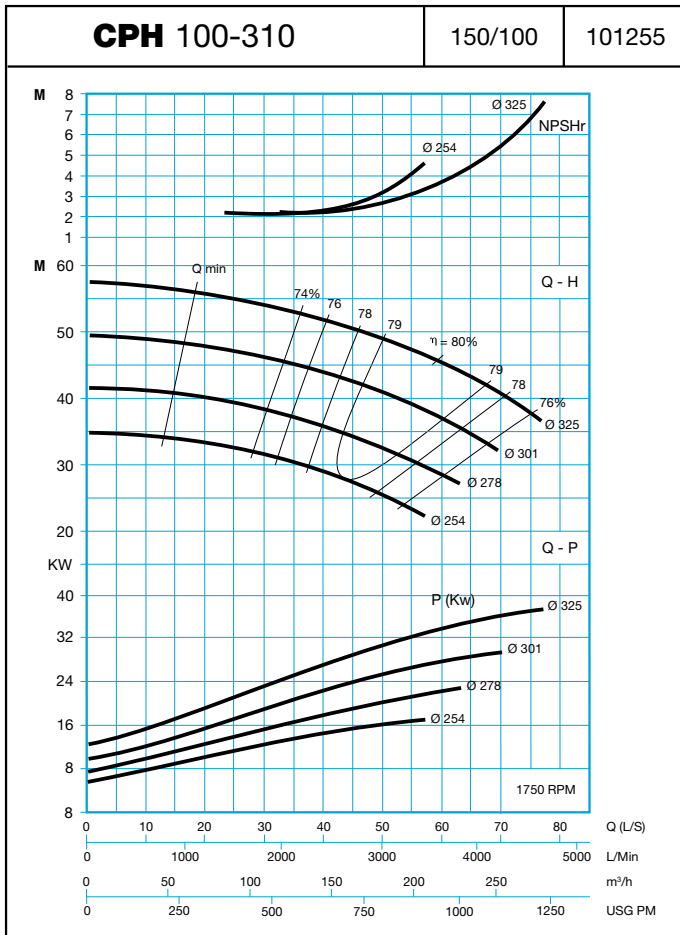

60Hz / 1750 RPM

CPH 125-365

200/125

101259

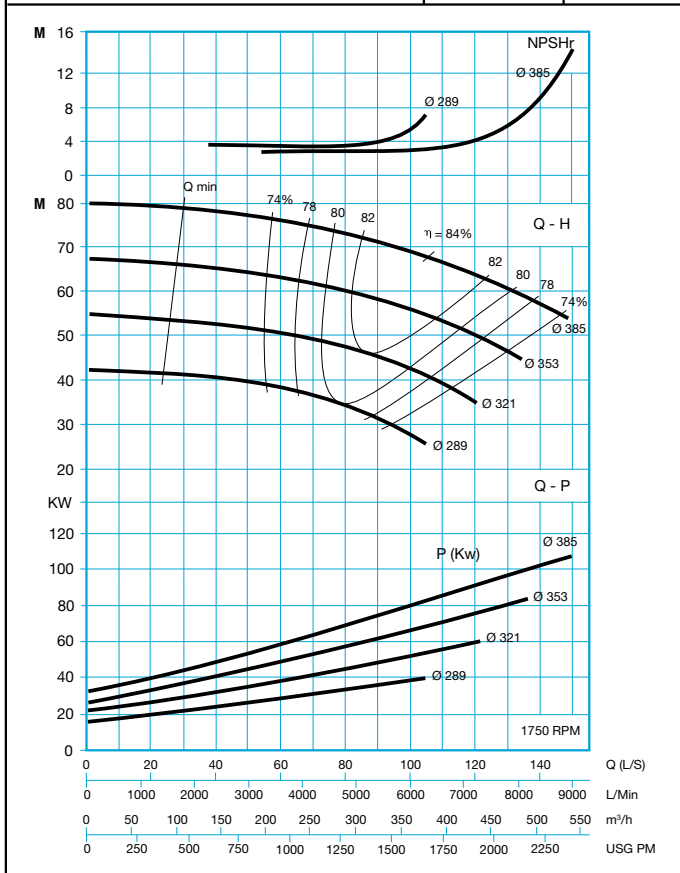

CPR 125-400 2M

150/125

101250

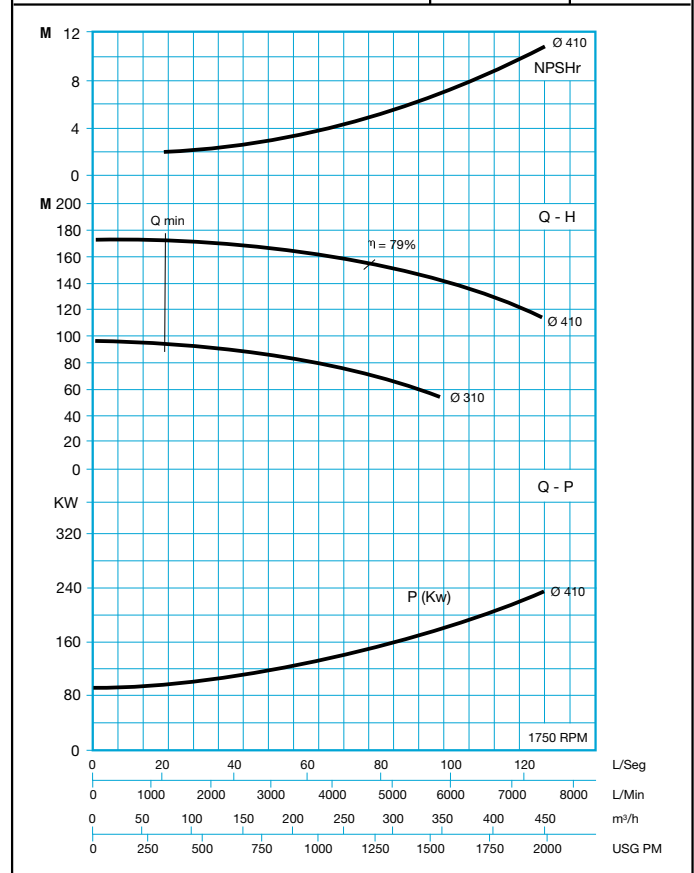

CPH 125-500

200/125

101260

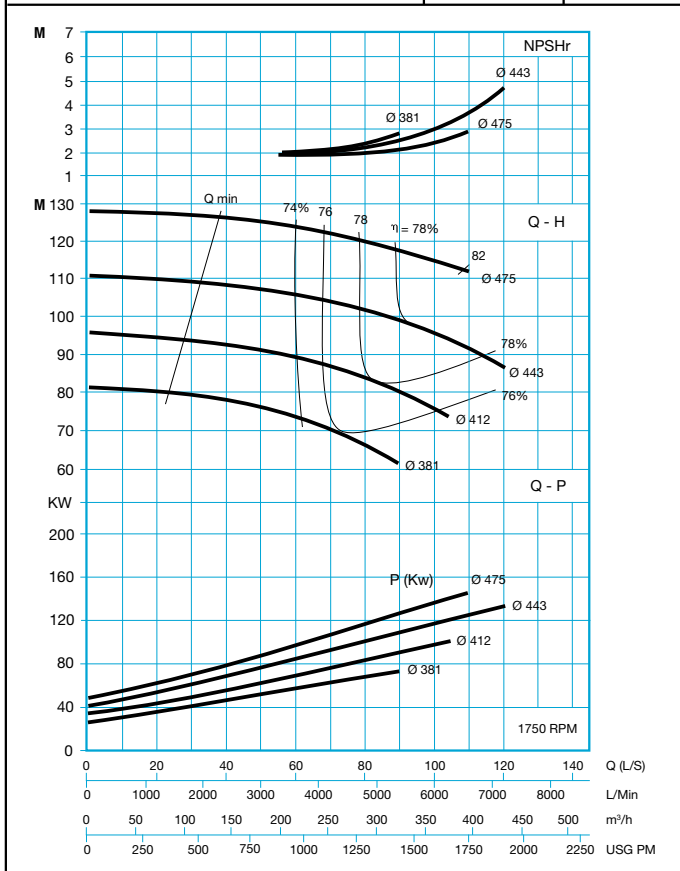

CPH 150-290

200/150

101261

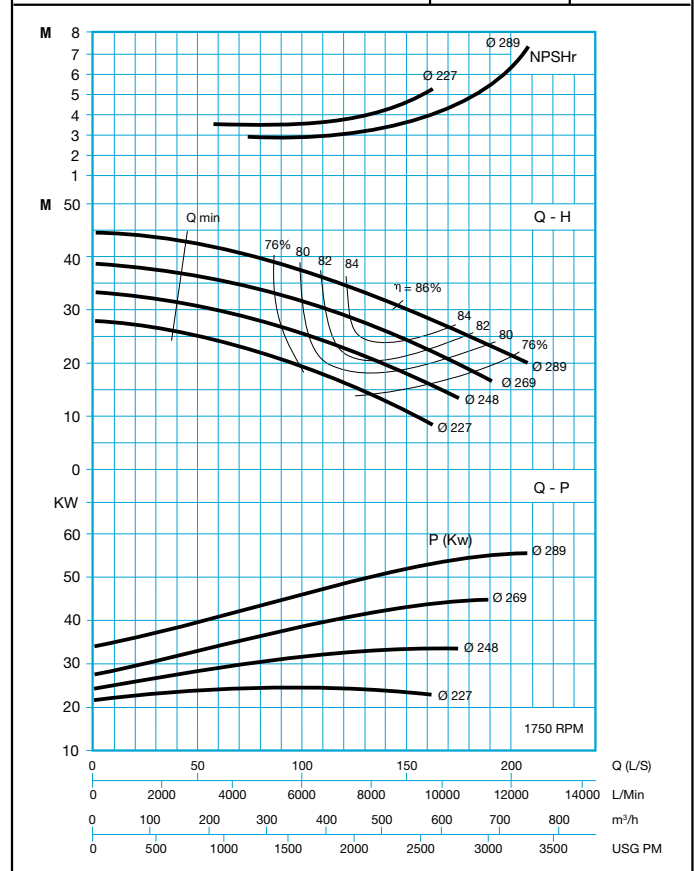

60Hz / 1750 RPM

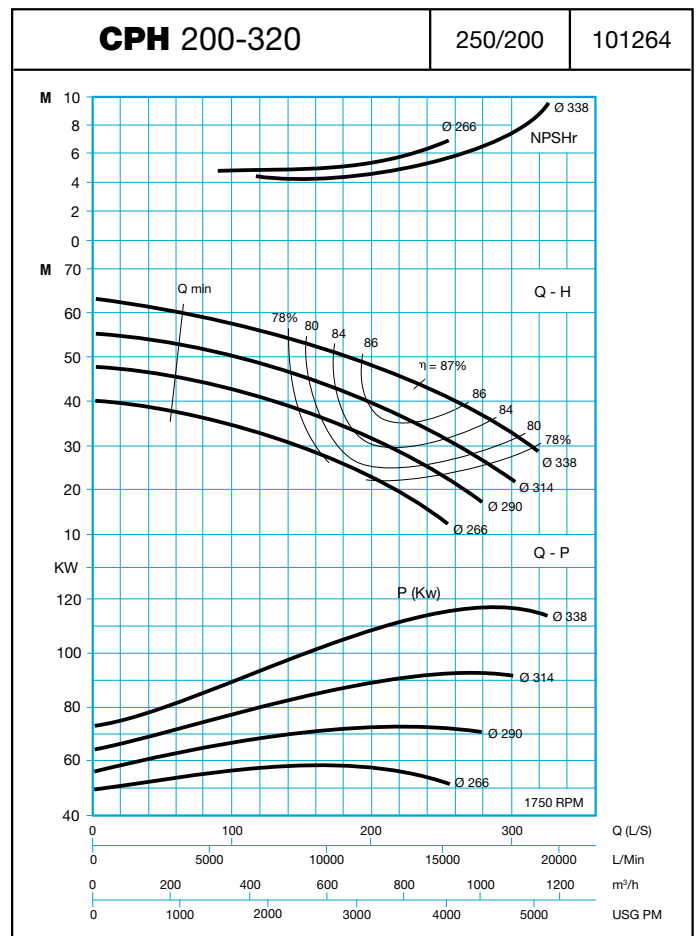
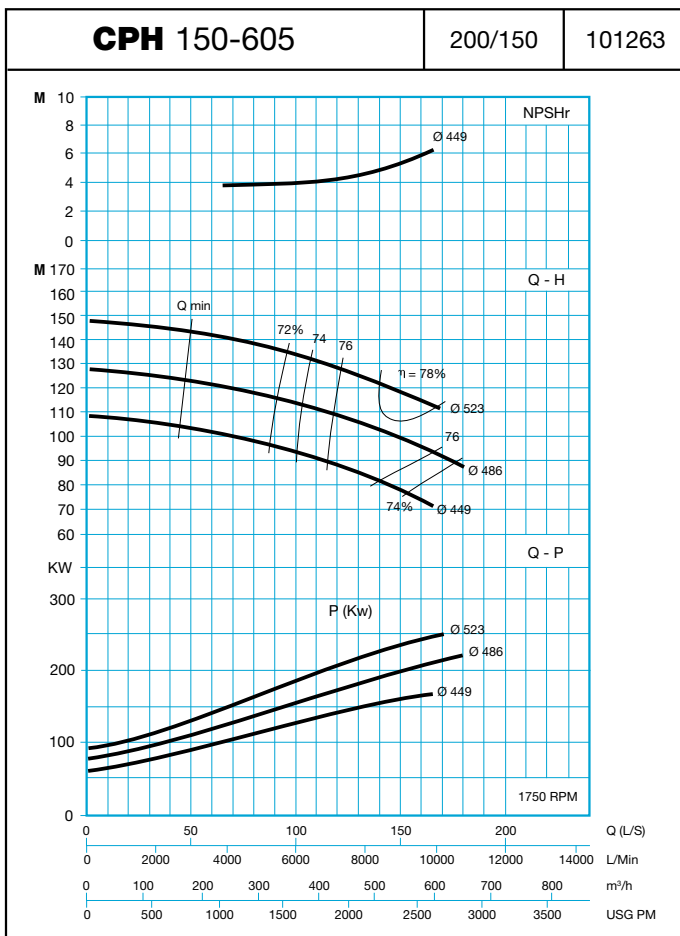
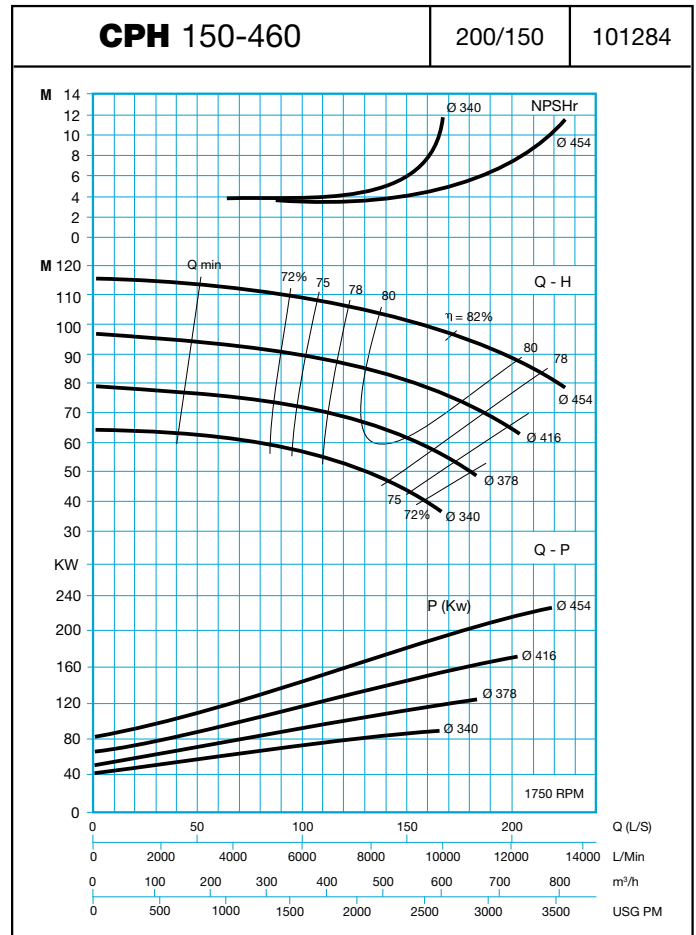
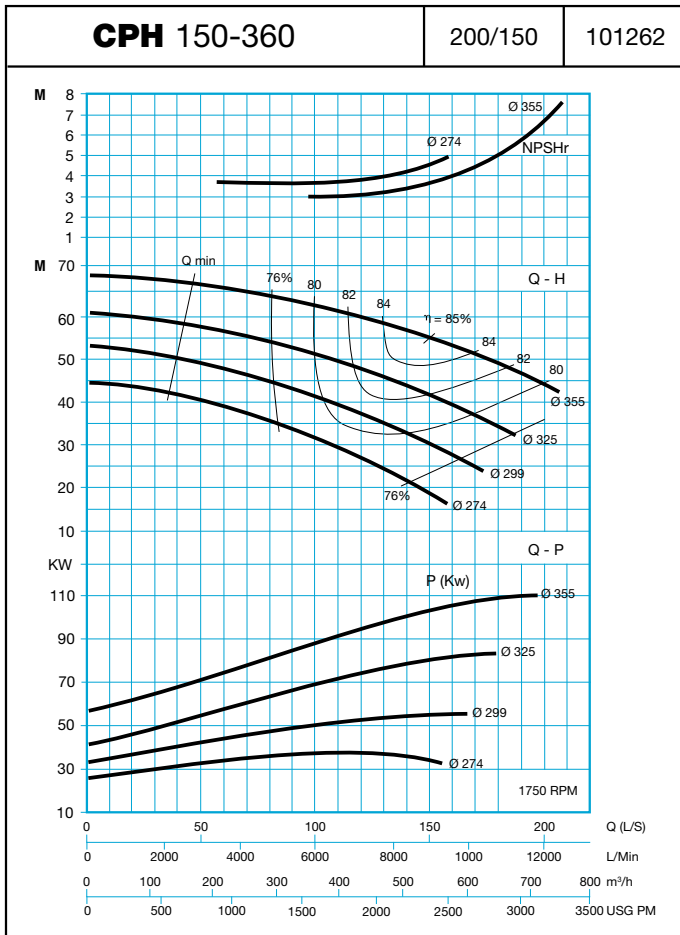

60Hz / 1750 RPM

CPH 200-420

250/200

101265

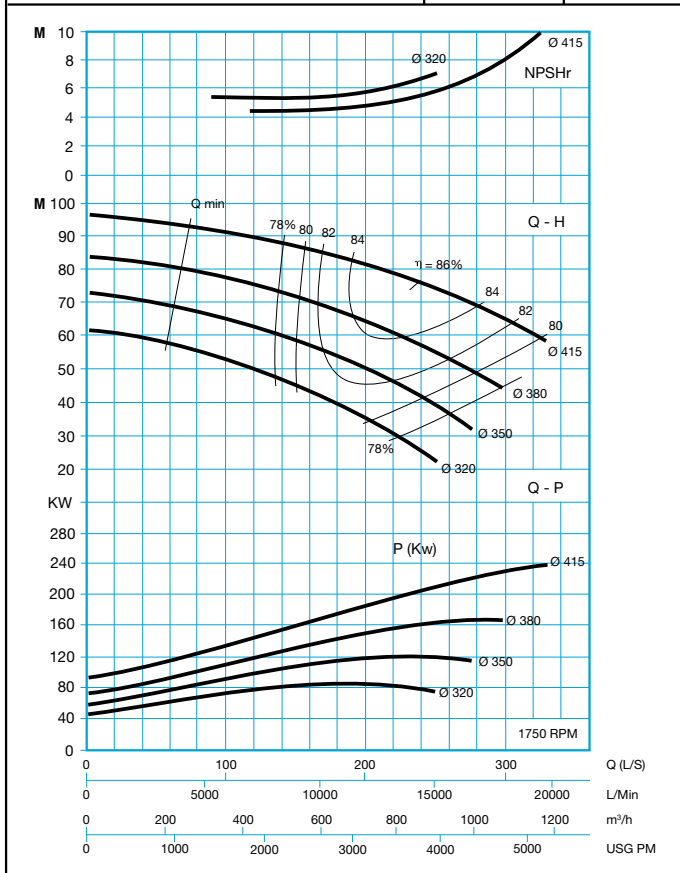

CPH 200-520

250/200

101266

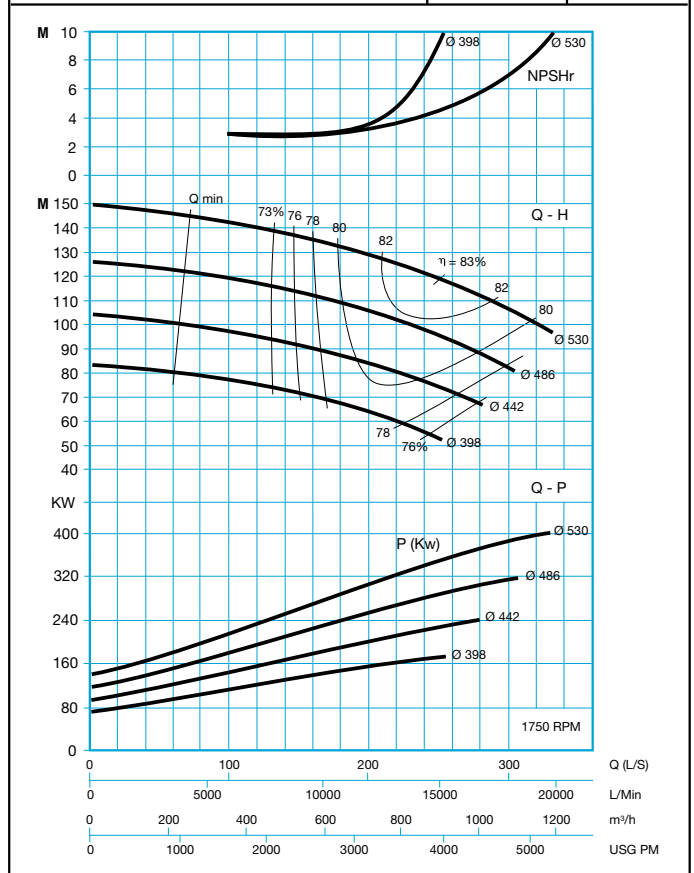

CPH 200-670

250/260

101267

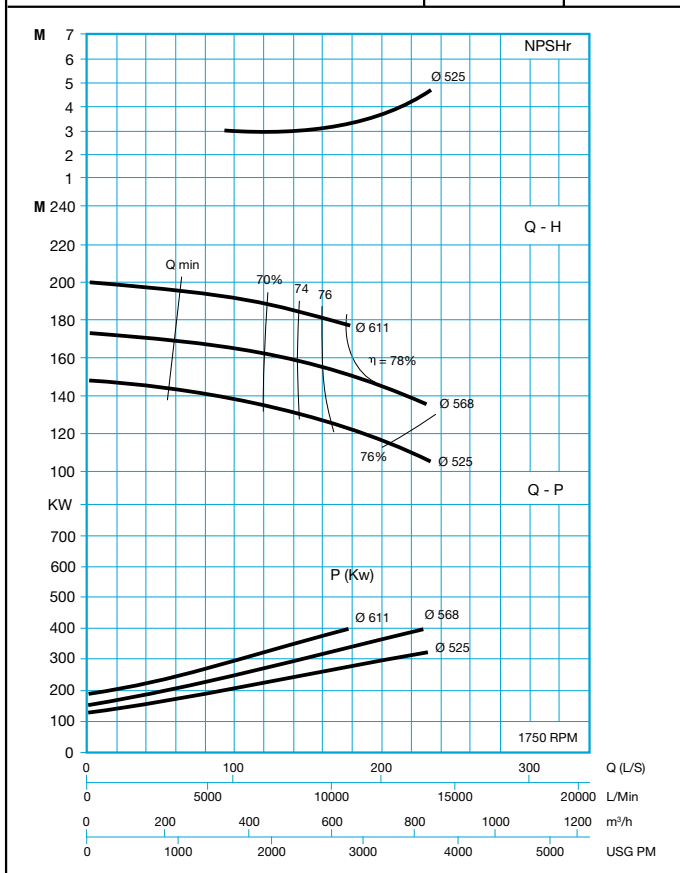

CPH 250-370

300/250

101268

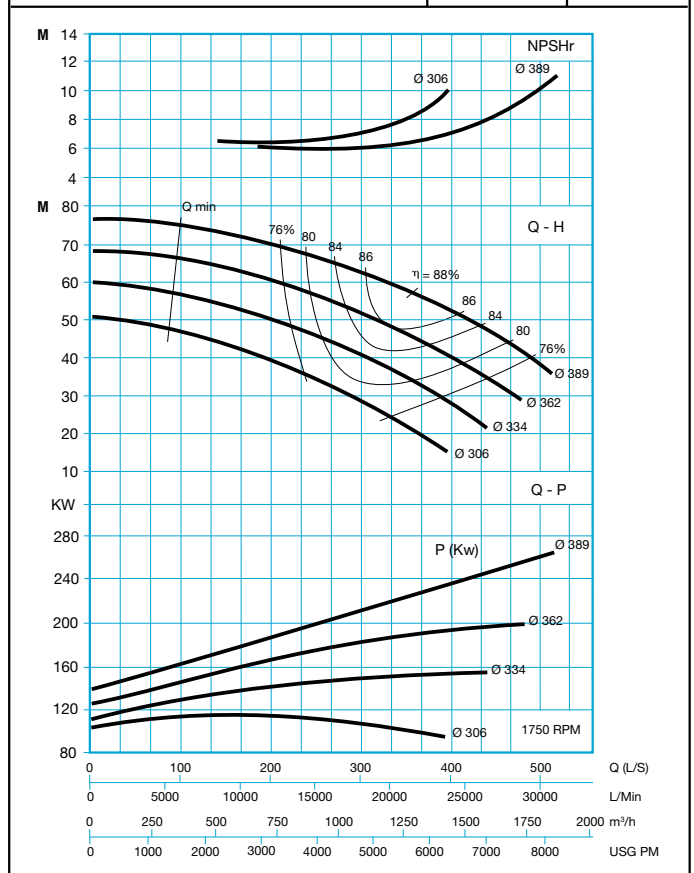

60Hz / 1750 RPM

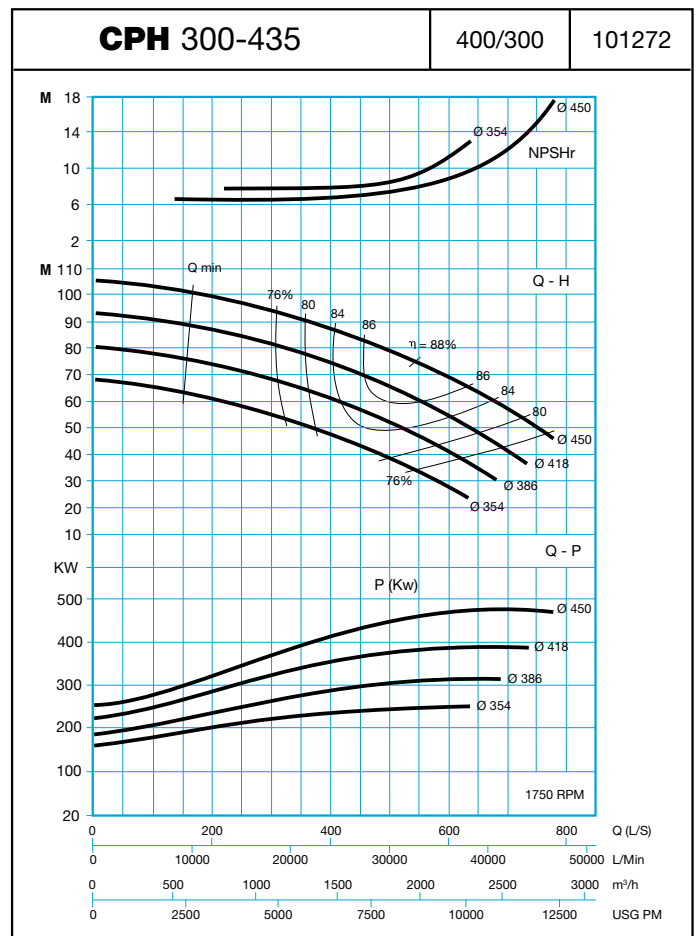
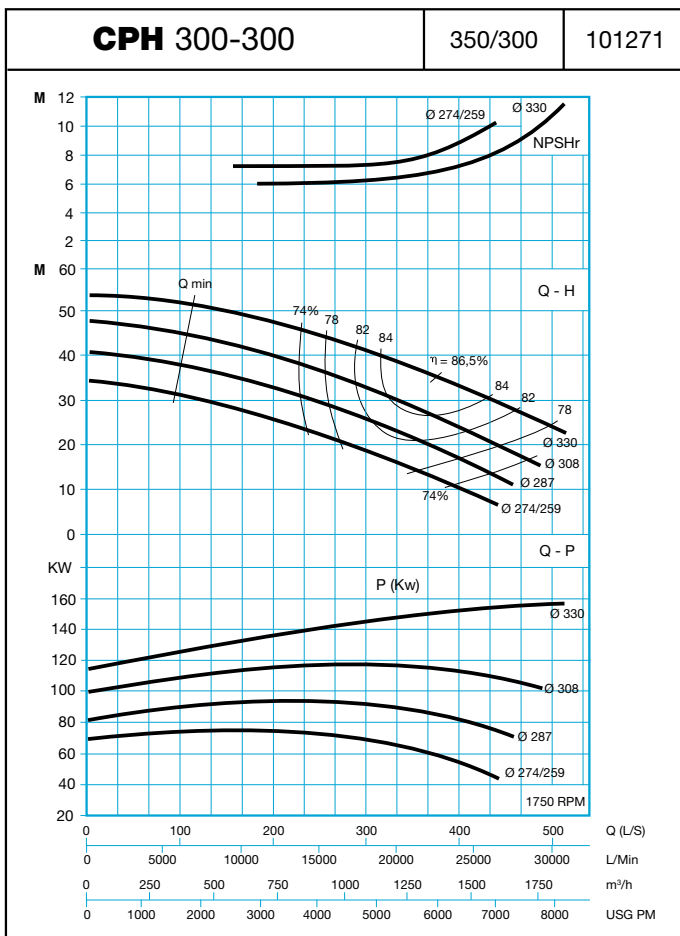
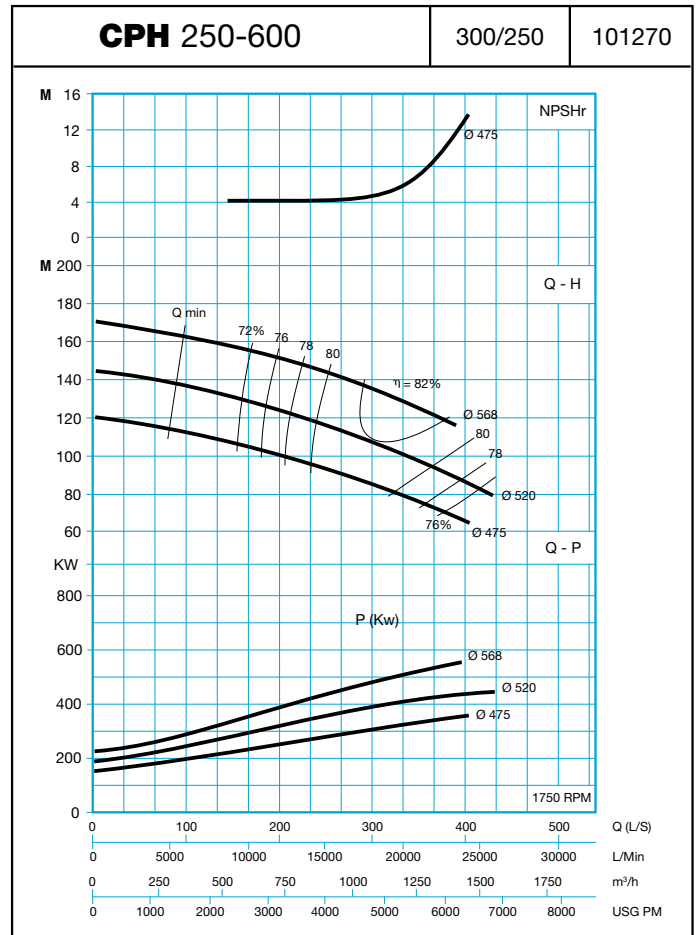
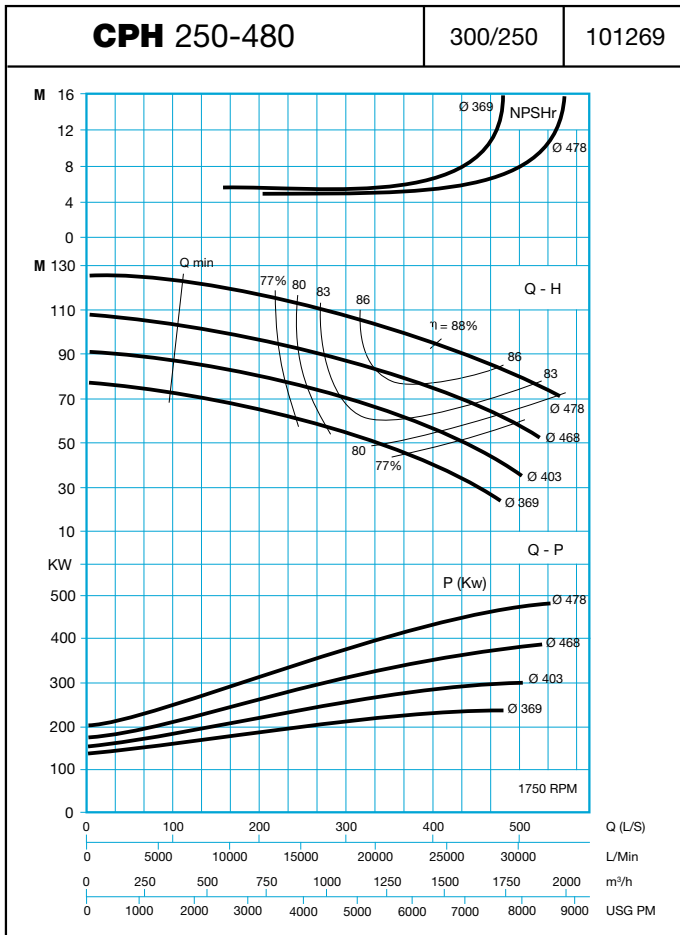

60Hz / 1750 RPM

CPH 300-560

400/300

101273

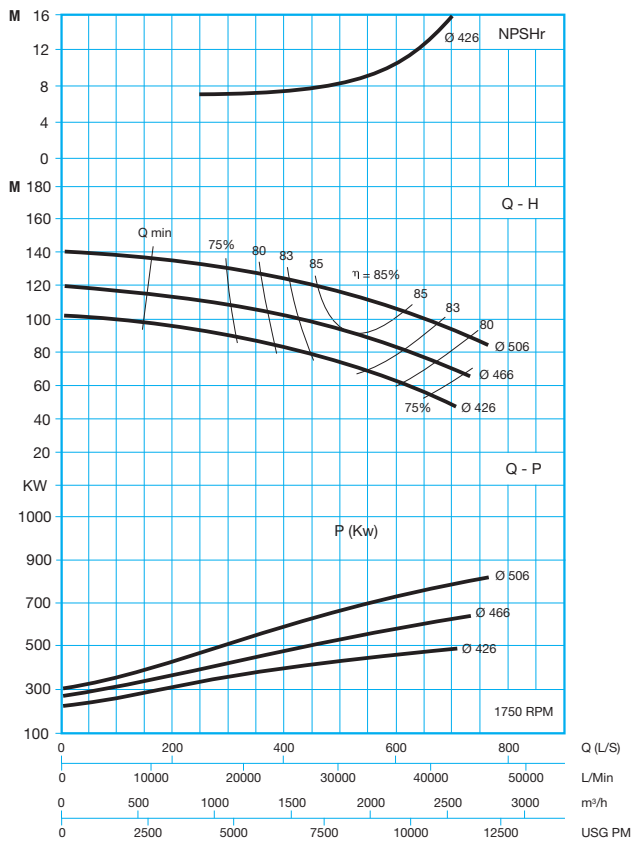

CPH 300-700

400/300

101274

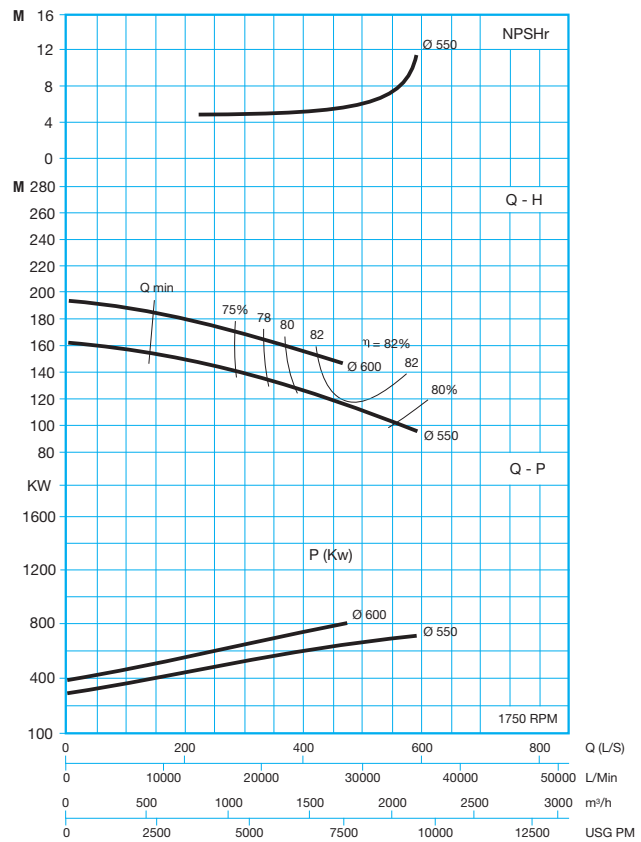

CPH 350-360

400/350

101275

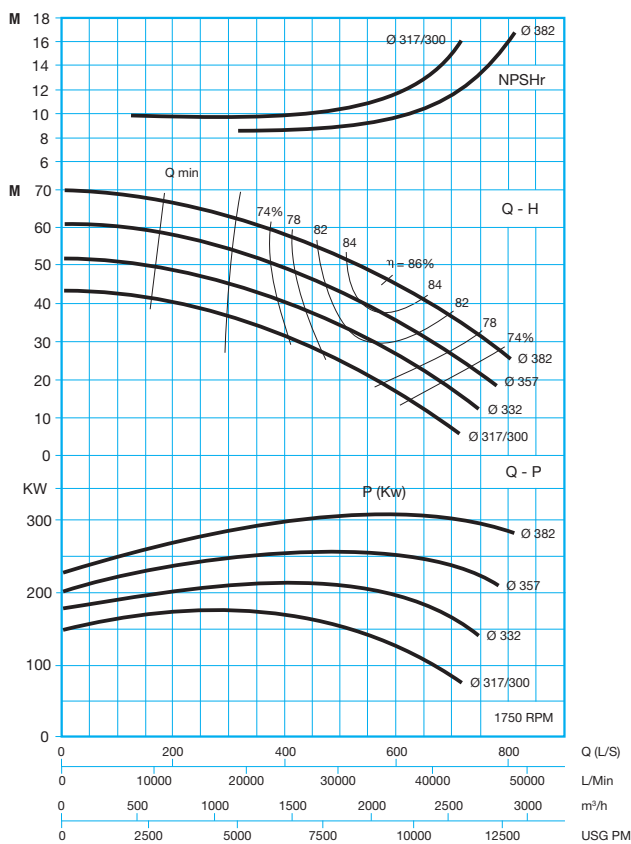

60Hz / 1750 RPM

Límites de funcionamiento / **Operational Limits** / Limites de Fonctionnement

Tipo / Type	Velocidad Speed Vitesse	Hierro fundido Cast Iron Fonte GG25 Kg/cm ²		Hierro fundido Cast Iron Fonte GG40 Kg/cm ²		Bronce Bronze Rg5 Kg/cm ²		Acero Inox. St. Steel Acier Inox. AISI 304-316 Kg/cm ²		Inercia Inertia (1)	Rodamientos Bearings Roulements	Vertical	Empaquetadura Packing Garniture
	Máx RPM	Pt	Pp	Pt	Pp	Pt	Pp	Pt	Pp	Kg · m ²			
CPI 65-240	3600	16	25	24	37,5	16	25	24	37,5	0,035	6306	V	10x10x145 / 11 pcs
CPI 80-300	3000	16	25	24	37,5	16	25	24	37,5	0,051	6306	V	10x10x145 / 11 pcs
CPR 50-200 / 2M	1800	12,5	25	18,7	37,5	12,5	25	18,7	37,5	0,04	6307	-	10x10x207 / 10 pcs
CPR 50-250 / 2M	1800	5,5	11	8,2	16,5	5,5	11	8,2	16,5	0,055	6306	-	10x10x145 / 11 pcs
CPR 65-250 / 2M	3000	14	28	21	42	14	28	21	42	0,1	6309/6408	-	10x10x207 / 10 pcs
CPR 65-315 / 2M	1800	7	14	10,5	21	7	14	10,5	21	0,17	6306	-	10x10x145 / 11 pcs
CPR 80-315 / 2M	1500	9	18	13,5	27	9	18	13,5	27	0,26	6307	-	10x10x207 / 10 pcs
CPR 100-315 / 2M	1500	10	20	15	30	10	20	15	30	0,355	6307/3307	-	10x10x207 / 11 pcs
CPR 125-400 / 2M	1800	12	24	18	36	12	24	18	36	0,56	6309/3309	-	12,5x12,5x290 / 11 pcs
CPR 150-400 / 2M	1600	13	26	19,6	39	13	26	19,6	39	0,81	N311/7310BG	-	12,5x12,5x290 / 11 pcs
CPH 80-210	3500	16	25	24	37,5	16	25	24	37,5	0,019	6308	V	10x10x204 / 10 pcs
CPH 80-270	3500	16	25	24	37,5	16	25	24	37,5	0,033	6308	V	10x10x204 / 10 pcs
CPH 80-370	1800	16	25	24	37,5	16	25	24	37,5	0,026	6308	V	10x10x204 / 10 pcs
CPH 100-250	3500	16	25	24	37,5	16	25	24	37,5	0,045	6308	V	10x10x204 / 10 pcs
CPH 100-310	3500	25	40	37,5	60	25	40	37,5	60	0,089	6308	V	10x10x204 / 10 pcs
CPH 100-375	1800	16	25	24	37,5	16	25	24	37,5	0,23	6308	V	10x10x204 / 10 pcs
CPH 125-230	1800	16	25	24	37,5	16	25	24	37,5	0,016	6309	V	12x12x227,5 / 10 pcs
CPH 125-290	1800	25	40	37,5	60	25	40	37,5	60	0,118	6309	V	12x12x227,5 / 10 pcs
CPH 125-365	1800	16	25	24	37,5	16	25	24	37,5	0,258	6309	V	12x12x227,5 / 10 pcs
CPH 125-500	1800	16	25	24	37,5	16	25	24	37,5	0,674	6309	V	12x12x227,5 / 10 pcs
CPH 150-290	1800	16	25	24	37,5	16	25	24	37,5	0,163	6309	V	12x12x227,5 / 10 pcs
CPH 150-360	1800	16	25	24	37,5	16	25	24	37,5	0,184	6309	V	12x12x227,5 / 10 pcs
CPH 150-460	1800	16	25	24	37,5	16	25	24	37,5	0,433	6311	V	12x12x259 / 10 pcs
CPH 150-605	1800	25	40	37,5	60	25	40	37,5	60	0,995	6311	V	12x12x259 / 10 pcs
CPH 200-320	1800	16	25	24	37,5	16	25	24	37,5	0,425	6311	V	12x12x259 / 10 pcs
CPH 200-420	1800	16	25	24	37,5	16	25	24	37,5	0,571	6311	V	12x12x259 / 10 pcs
CPH 200-520	1800	16	25	24	37,5	16	25	24	37,5	1,631	6313	V	13x13x309 / 10 pcs
CPH 200-670	1800	25	40	37,5	60	25	40	37,5	60	3,574	6313	V	13x13x309 / 10 pcs
CPH 250-370	1800	16	25	24	37,5	16	25	24	37,5	0,728	6313	V	13x13x309 / 10 pcs
CPH 250-480	1800	16	25	24	37,5	16	25	24	37,5	0,933	6315	V	16x16x340,5 / 10 pcs
CPH 250-600	1800	25	40	37,5	60	25	40	37,5	60	2,193	6315	V	18x18x340,5 / 10 pcs
CPH 250-710	1600	25	40	37,5	60	25	40	37,5	60	2,811	6315	V	18x18x340,5 / 10 pcs
CPH 300-300	1800	16	25	24	37,5	16	25	24	37,5	0,563	6313	V	13x13x309 / 10 pcs
CPH 300-435	1800	16	25	24	37,5	16	25	24	37,5	1,774	6315	V	18x18x340 / 10 pcs
CPH 300-560	1800	16	25	24	37,5	16	25	24	37,5	2,392	6317	V	18x18x340 / 10 pcs
CPH 300-700	1800	25	40	37,5	60	25	40	37,5	60	6,413	6317	V	20x20x408 / 10 pcs
CPH 350-360	1800	16	25	24	37,5	16	25	24	37,5	1,108	6317	V	20x20x408 / 10 pcs
CPH 350-430	1500	16	25	24	37,5	16	25	24	37,5	2,195	6317	V	20x20x408 / 10 pcs
CPH 350-510	1500	16	25	24	37,5	16	25	24	37,5	3,415	6317	V	20x20x408 / 10 pcs
CPH 350-590	1500	16	25	24	37,5	16	25	24	37,5	3,933	6317	V	20x20x408 / 10 pcs
CPH 350-620	1500	25	40	37,5	60	25	40	37,5	60	4,573	NUP320/6320	-	20x20x471 / 10 pcs
CPH 400-540	1500	16	25	24	37,5	16	25	24	37,5	4,862	NUP320/6320	-	20x20x471 / 10 pcs
CPH 400-620	1500	25	40	37,5	60	25	40	37,5	60	5,21	NUP320/6320	-	20x20x471 / 10 pcs
CPH 500-510	1200	16	25	24	37,5	16	25	24	37,5	6,07	NUP317/6317	-	20x20x408 / 10 pcs
CPH 500-640	1200	16	25	24	37,5	16	25	24	37,5	7,541	NUP320/6320	-	20x20x471 / 10 pcs
CPH 500-700	1200	16	25	24	37,5	16	25	24	37,5	9,413	NUP322/6322	-	20x20x502,5 / 10 pcs
CPH 500-790	1200	16	25	24	37,5	16	25	24	37,5	9,754	-	-	20x20x502,5 / 10 pcs
CPH 500-890	1200	16	25	24	37,5	16	25	24	37,5	10,23	-	-	20x20x502,5 / 10 pcs
CPH 600-540	1200	16	25	24	37,5	16	25	24	37,5	9,275	NUP317/6317	-	20x20x424 / 10 pcs

Pp: Presión máxima hidroestática / **Hydrostatic pressure test** / Pression essais hydrostatiques

Pt: Máxima presión de trabajo / **Maximum working pressure** / Pression maximum de travail

(1): Impulsor de hierro fundido GG25 / **Impeller in cast iron GG25** / Roue en fonte GG25

V: Opcional construcción vertical / **Vertical construction request** / Construction vertical sur demande

Dimensiones / Dimensions CPR-2M

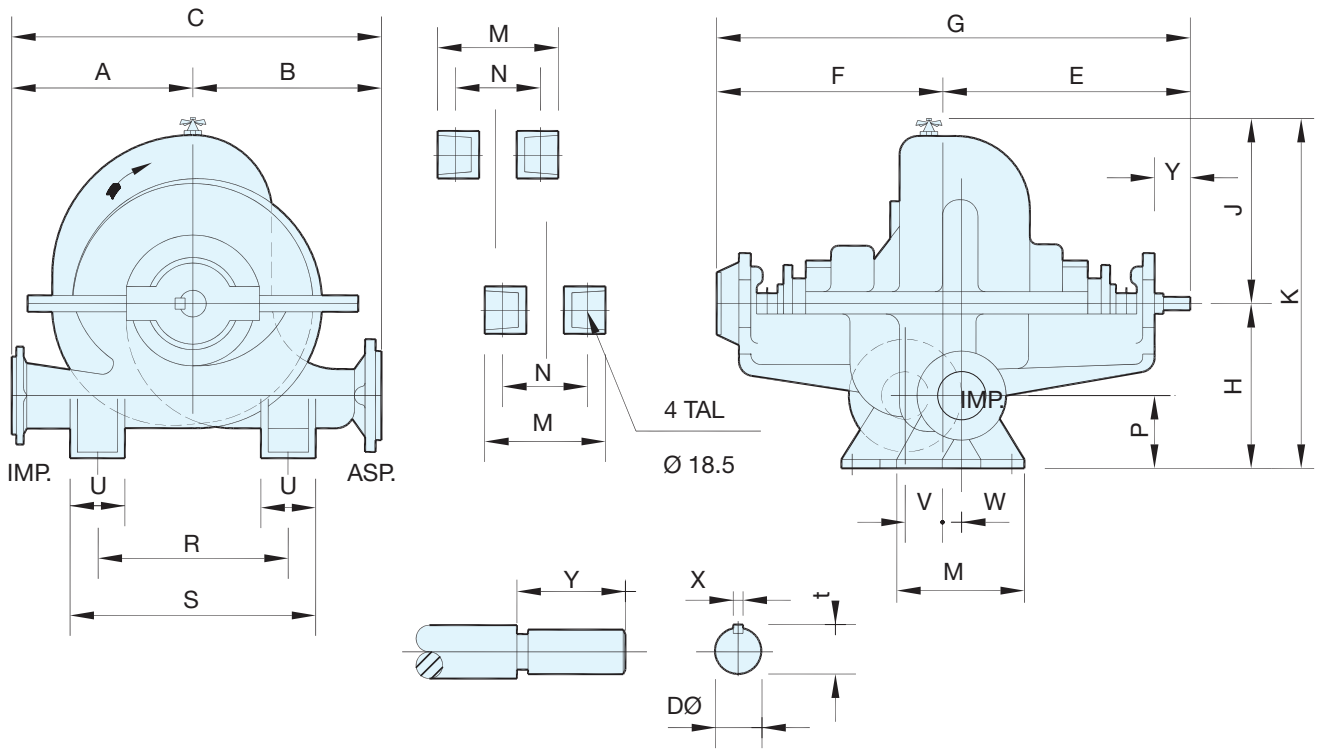

Rotación horaria visto desde acoplamiento / Direction of rotation clockwise from coupling end / Sens rotation horaire vu cote accouplement

Tipo / Type	Ø SUC Ø ASP	Ø DEL Ø IMP	A	B	C	E	F	G	H	J	K	M	N
CPR 50-200/2M	80	50	225	225	450	400	232	732	230	217	200	160	120
CPR 50-250/2M	65	50	225	250	475	374	316	690	245	230	475	160	120
CPR 65-250/2M	100	65	250	250	500	435	367	802	260	252	512	200	150
CPR 65-315/2M(A)	80	65	275	275	550	378	349	766	285	265	550	200	150
CPR 65-315/2M(B)	80	65	275	275	550	378	349	766	285	265	550	200	150
CPR 80-315/2M	100	80	265	300	565	431	358	789	290	305	595	200	160
CPR 100-315/2M	125	100	340	350	690	540	441	981	350	352	702	260	210
CPR 125-400/2M	150	125	365	375	740	575	479	1054	400	420	820	360	300
CPR 150-400/2M	200	150	400	425	825	630	623	1129	425	495	920	360	300

Tipo / Type	Ø SUC Ø ASP	Ø DEL Ø IMP	P	R	S	U	V	W	X	Y	t	D	KG
CPR 50-200/2M	80	50	105	245	325	80	65	30	8	70	33	30	118
CPR 50-250/2M	65	50	95	245	325	80	65	25	8	60	28	25	120
CPR 65-250/2M	100	65	115	270	350	80	65	33	10	72	42	38	164
CPR 65-315/2M(A)	80	65	105	310	390	80	70	30	8	60	28	25	180
CPR 65-315/2M(B)	80	65	105	310	390	80	70	30	8	60	28	25	177
CPR 80-315/2M	100	80	120	300	400	100	80	33	10	75	36	32	215
CPR 100-315/2M	125	100	140	400	520	120	110	34	10	99	36	32	325
CPR 125-400/2M	150	125	150	400	520	120	100	40	12	80	46	42	478
CPR 150-400/2M	200	150	175	505	625	120	150	45	14	120	54	50	612

Dimensiones / Dimensions CPI / CPH

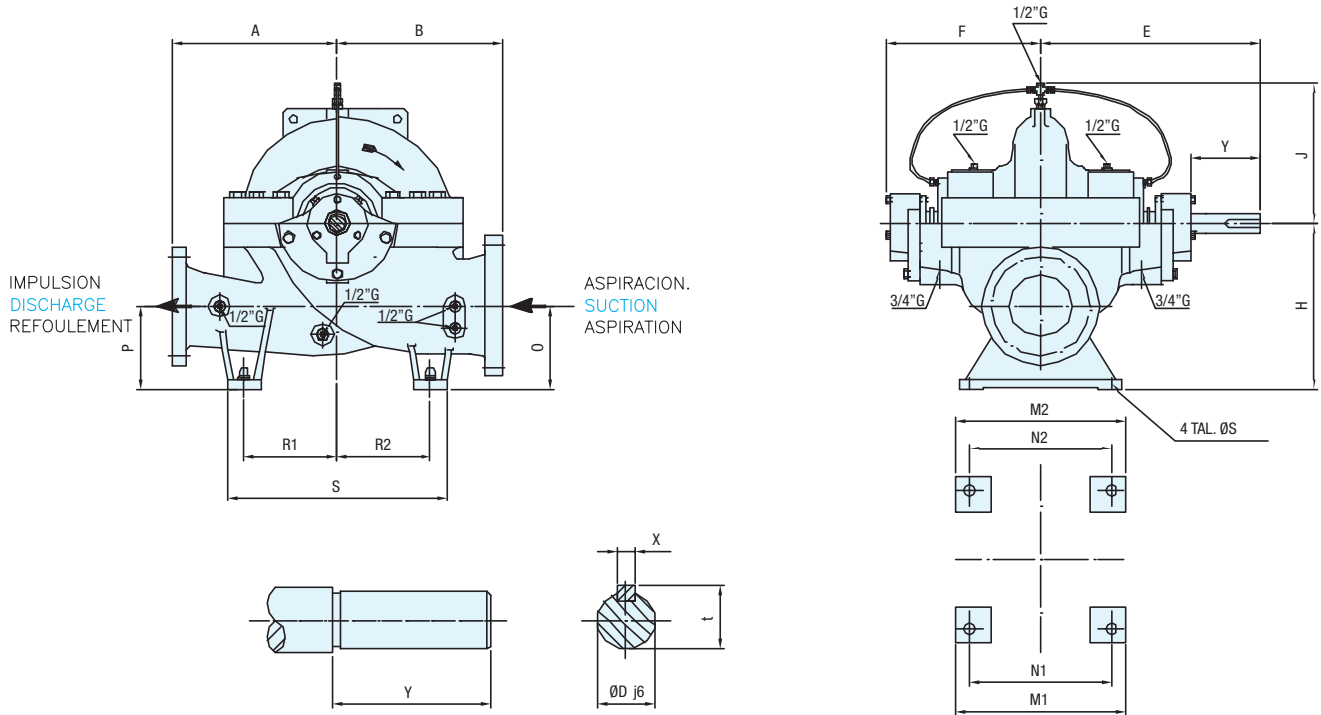

Rotación horaria visto desde acoplamiento / Direction of rotation clockwise from coupling end / Sens rotation horaire vu cote accouplement

Tipo / Type	Ø ASP Ø SUC	PN	Ø IPM Ø DEL	PN	A	B	E	F	H	J	M1	M2	N1	N2	O	P	R1	R2	S	X	Y	t	DØ	SØ	Kg
CPI 65-240	80	16	65	16	225	280	314	246	250	254	300	300	240	240	120	120	145	145	350	8	70	28	25	23	120
CPI 80-300	100	16	80	16	275	290	314	246	280	274	300	300	240	240	130	130	145	145	350	8	70	28	25	23	150
CPH 80-210	125	16	80	16	300	300	385	306	315	240	320	320	270	270	175	175	170	170	410	12	80	43	40	17,5	185
CPH 80-270	125	16	80	16	300	300	385	306	315	240	320	320	270	270	175	175	170	170	410	12	80	43	40	17,5	195
CPH 80-370	125	16	80	16	330	330	385	306	315	445	320	320	270	270	175	175	170	170	410	12	80	43	40	17,5	205
CPH 100-250	150	16	100	16	330	330	385	306	355	405	320	320	270	270	185	185	200	200	470	12	80	43	40	23	210
CPH 100-310	150	16	100	16	330	330	385	306	355	405	320	320	270	270	185	185	200	200	470	12	80	43	40	23	225
CPH 100-375	150	16	100	16	370	370	385	306	355	405	320	320	270	270	185	185	200	200	470	12	80	43	40	23	245
CPH 125-230	200	16	125	16	370	370	515,5	377	400	425	390	390	340	340	200	200	225	225	530	14	110	48	45	23	250
CPH 125-290	200	16	125	16	370	370	515,5	377	400	425	390	390	340	340	200	200	225	225	530	14	110	48	45	23	275
CPH 125-365	200	16	125	16	370	370	515,5	377	400	425	390	390	340	340	200	200	225	225	530	14	110	48	45	23	300
CPH 125-500	200	16	125	16	450	450	517	377	400	425	390	390	340	340	200	200	280	280	630	14	110	48	45	22	335
CPH 150-290	200	16	150	16	400	400	515,5	376	400	650	390	390	340	340	200	200	225	225	530	14	110	48	45	23	350
CPH 150-360	200	16	150	16	400	400	515,5	376	400	650	390	390	340	340	200	200	225	225	530	14	110	48	45	23	360
CPH 150-460	200	16	150	16	450	450	591	431	400	650	480	480	430	430	200	200	280	280	630	16	125	58,5	55	23	436
CPH 150-605	200	25	150	25	500	600	591	431	500	550	480	480	430	430	200	200	350	350	770	16	125	58,5	55	23	646
CPH 200-320	250	16	200	16	450	450	591	425	500	365	480	480	430	430	260	260	280	280	630	16	125	58,5	55	23	450
CPH 200-420	250	16	200	16	500	500	591	425	500	365	480	480	430	430	260	260	280	280	630	16	125	58,5	55	23	520
CPH 200-520	250	16	200	16	500	600	655	476	560	680	480	480	430	430	260	260	350	350	770	18	125	69	65	23	840
CPH 200-670	250	25	200	25	550	650	655	476	600	640	480	480	400	400	250	250	350	350	800	18	125	69	65	27	990
CPH 250-370	300	16	250	10	500	500	655	472	600	460	480	480	400	400	300	300	350	350	800	18	125	69	65	23	665
CPH 250-480	300	16	250	16	550	550	730,5	523	600	365	600	600	520	520	300	300	350	350	800	20	140	79,5	75	27	830
CPH 250-600	300	25	250	25	550	650	730,5	523	630	435	600	600	520	520	280	280	350	350	800	20	140	79,5	75	22	1215
CPH 250-710	300	25	250	25	650	700	793	580	710	580	600	600	520	520	280	280	450	450	1020	22	180	90	85	22	1960
CPH 300-300	350	16	300	10	500	550	645,5	472	630	800	480	480	400	400	330	330	350	350	800	18	125	69	65	22	830
CPH 300-435	400	16	300	10	550	650	731	523	670	760	600	600	520	520	320	320	350	350	800	20	140	79,5	75	27	1425
CPH 300-560	400	16	300	16	650	700	810,5	605	710	720	600	600	520	520	360	360	475	475	1050	22	170	90	85	27	1425
CPH 300-700	400	25	300	25	650	750	810,5	605	750	680	600	600	520	520	350	350	475	475	1050	22	170	90	85	27	1690
CPH 350-360	400	16	350	10	550	650	730,5	523	670	435	600	600	520	520	320	320	350	350	800	20	140	79,5	75	27	865
CPH 350-430	450	16	350	10	650	750	810,5	605	750	485	600	600	520	520	350	350	475	475	1050	22	170	90	85	27	1285
CPH 350-510	400	16	350	10	650	700	810,5	605	750	480	600	600	520	520	350	350	475	475	1050	22	170	90	85	27	1395
CPH 350-590	500	16	350	16	650	731	822	670	760	499	680	930	560	810	350	350	385	445	1050	25	170	100	95	39	1977
CPH 350-620	400	25	350	25	670	740	910,5	728	775	525	680	930	560	810	315	315	385	445	1050	25	170	100	95	39	2120
CPH 400-540	500	16	400	16	665	743	891	741	807	515	768	996	628	876	347	347	415	497	1012	25	170	100	95	41	2467
CPH 400-620	500	16	400	16	700	800	955,5	788	850	575	840	1090	720	970	360	360	455	555	1245	25	170	100	95	48	3400
CPH 500-510	600	16	500	16	750	850	1026	830	900	600	940	1240	820	1120	425	425	250	400	1050	20	140	79,5	75	42	2600
CPH 500-640	600	16	500	16	800	850	1116	888	920	595	940	1240	820	1120	425	425	450	450	1120	25	170	100	95	41	2301
CPH 500-700	600	16	500	16	850	1050	1086	906	1000	685	940	1340	820	1220	450	380	500	600	1320	28	180	111	105	41	2967
CPH 500-790	600	16	500	16	850	1050	1141	906	1000	732	940	1340	820	1220	450	380	500	600	1320	28	210	116	110	42	3725
CPH 500-890	600	16	500	16	950	1050	1210	953	1100	950	990	1240	910	1120	450	450	710	810	1520	36	250	143	135	46	4976
CPH 600-540	700	16	600	16	900	1100	1081	880	1100	670	950	1250	800	1100	490	490	550	650	1500	22	140	85	80	42	2725

Sección / Sectional view / Section

CPH-V

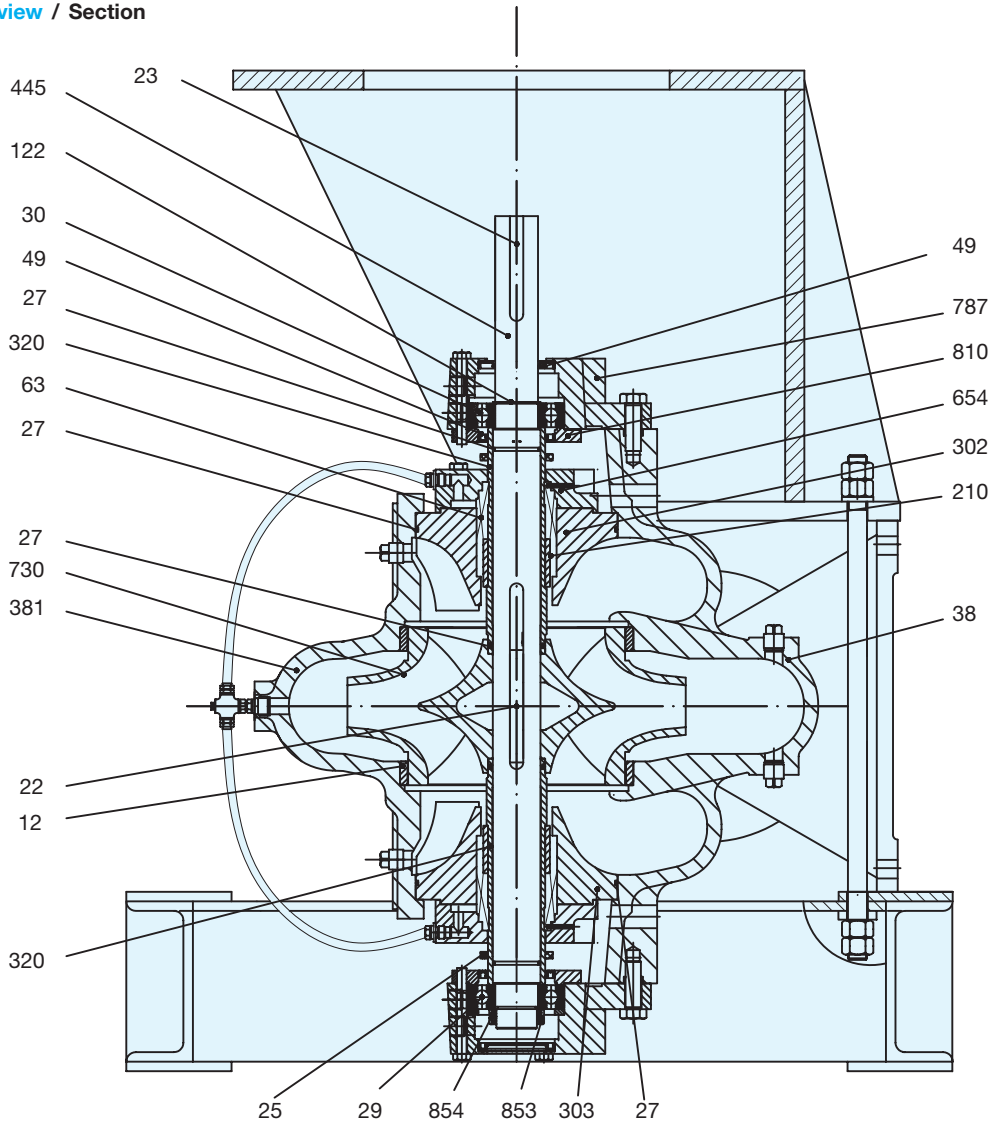

CPH

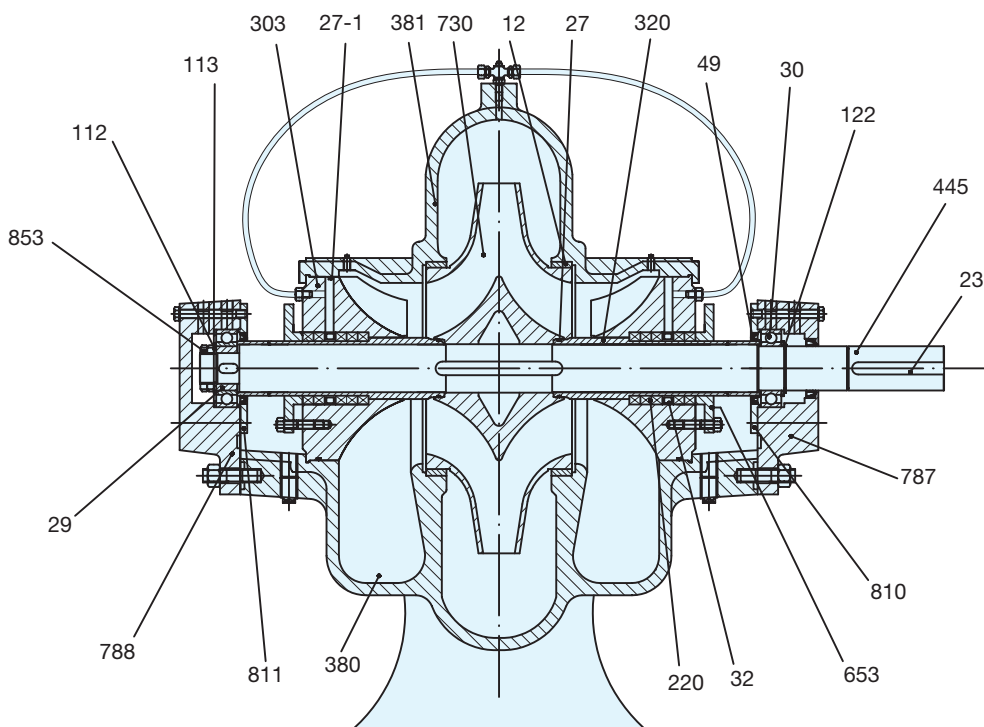

Sección / Sectional view / Section

CPR 2M

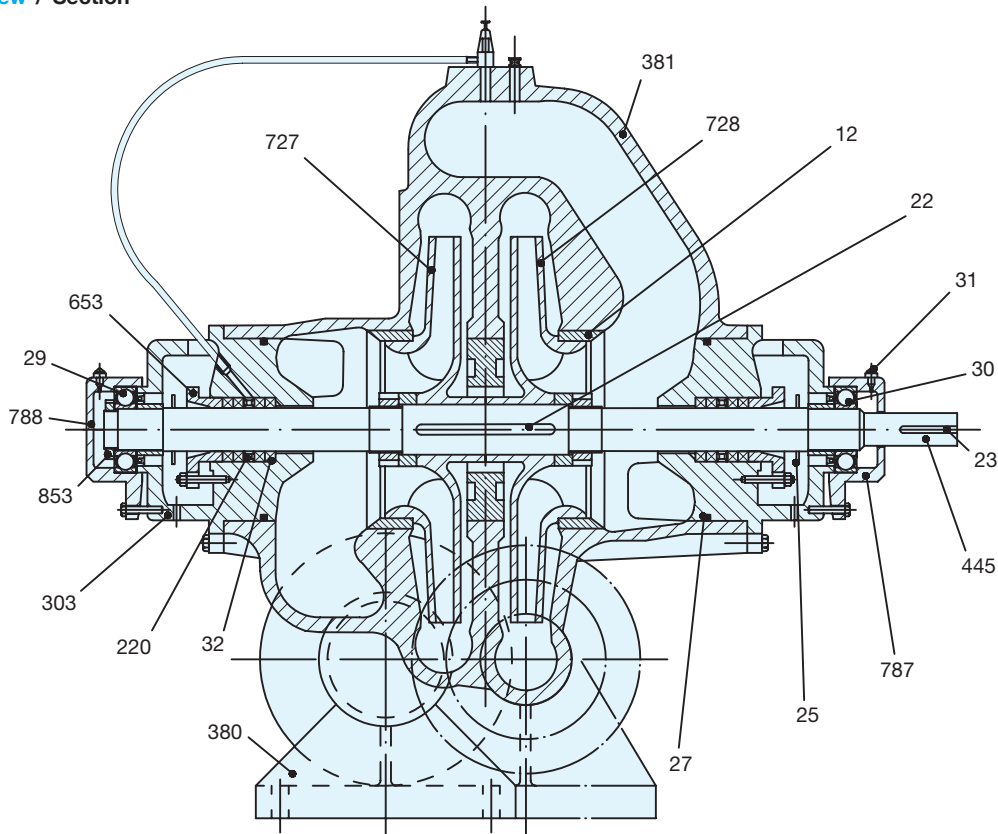

Nº	Denominación	Nº	Denomination	Nº	Denomination
* 12	Aro de cierre	12	Wear ring	12	Bague d'usure
22	Chaveta rodete	22	Impeller key	22	Clavette roue
23	Chaveta acoplamiento	23	Coupling key	23	Clavette accouplement
25	Deflector	25	Deflector	25	Deflecteur
* 27	Juego juntas	27	O'rings set	27	Jeu de jointif
* 29	Rodamiento posterior	29	Ball bearing N.D.E.	29	Roulement posterior
* 30	Rodamiento anterior	30	Ball bearing D.E.	30	Roulement anterior
31	Engrasador de bola	31	Nipple grease	31	Graisser
* 32	Empaquetadura	32	Packing	32	Garniture
49	Retén de aceite (juego)	49	Oil seal (set)	49	Joint a l'evre
63	Cierre mecánico	63	Mechanical seal	63	Garniture mecanique
112	Arandela	112	Washer	112	Rondelle
113	Arandela	113	Washer	113	Rondelle
122	Anillo elástico	122	—	122	—
210	Casquillo cierre mecánico	210	Mechanical seal front sleeve	210	Chemise
220	Aro refrigeración	220	Lantern ring	220	Bague lanterne
302	Caja prensa anterior	302	Packing box DE	302	Boite garniture anterior
303	Caja prensa posterior	303	Packing box N.D.E.	303	Boite garniture posterior
* 320	Casquillo prensa	320	Shaft sleeve	320	Chemise d'arbre
380	Cuerpo inferior	380	Bottom half casing	380	Corps inferieur
381	Cuerpo superior	381	Top half casing	381	Corps superieur
445	Eje de bomba	445	Pump shaft	445	Arbre de pompe
653	Prensa estopas	653	Packing gland	653	Press etoupe
654	Tapa cierre mecánico	654	Mechanical seal cover	654	Couvercle garniture mecanique
727	Rodete I etapa	727	Impeller I stage	727	Roue I etage
728	Rodete II etapa	728	Impeller II stage	728	Roue II etage
730	Rodete doble aspiración	730	Impeller	730	Roue double aspiration
787	Sop. rto. anterior (grasa)	787	Bearing housing D.E. (grease)	787	Corps palier ant. (graisse)
788	Sop. rto. posterior (grasa)	788	Bearing housing N.D.E. (grease)	788	Corps palier post. (graisse)
810	Tapa rto. anterior (grasa)	810	Bearing cover D.E. (grease)	810	Couvercle anterior (graisse)
811	Tapa rto. posterior (grasa)	811	Bearing cover N.D.E. (grease)	811	Couvercle posterior (graisse)
* 853	Tuerca izquierda	853	Left nut	853	Ecrou gauche
* 854	Tuerca fijación casquillo inferior	854	Lower sleeve locking nut	854	Ecrou blocage douille inferieure

* Repuestos recomendados / Recommended spares / Pièces de rechange conseillées

Materiales de fabricación / **Materials of construction** / Matériaux de construction

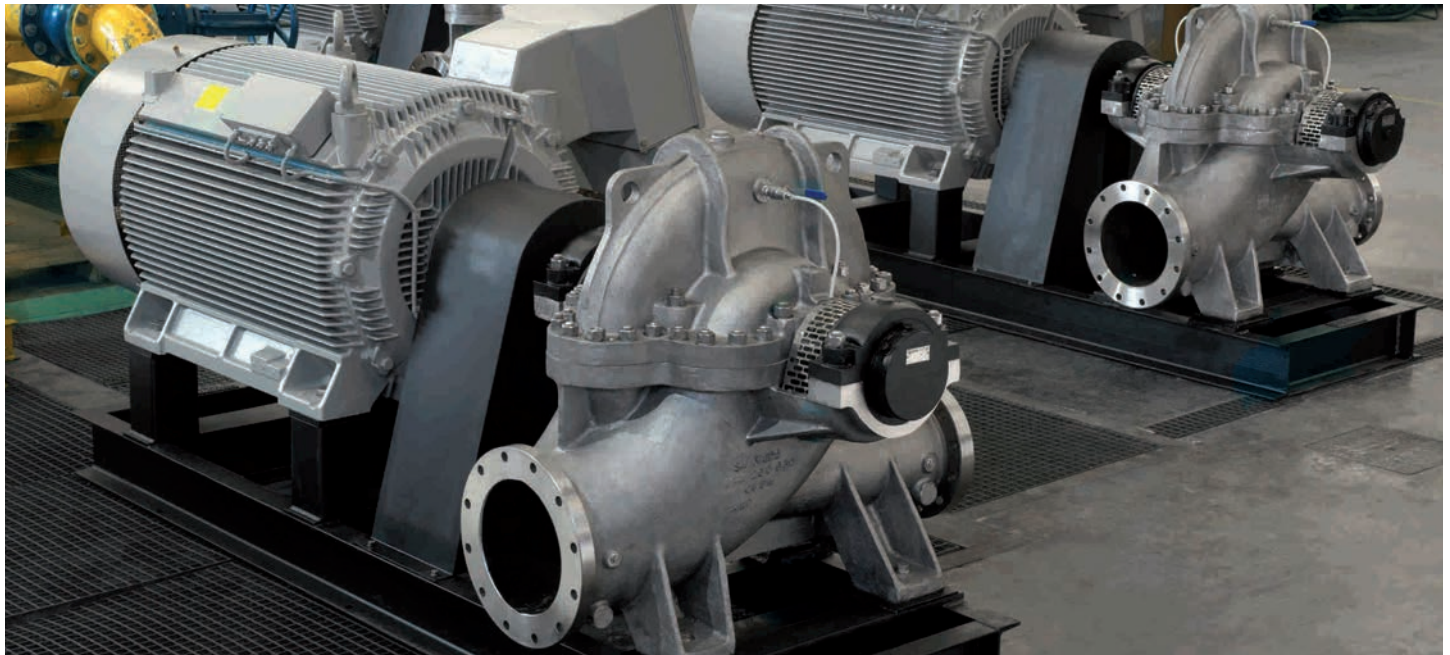

REF.	Componente / Component	Standard	IDEAL Tipo / Type					
			A	B	C	D 1	E 1	G 1 / F 1
			CI/CI/SS/GP	CI/BR/SS/GP	CI/SS304/SS/GP	SS304/SS304/SS/MS	SS316/SS316/SS/MS	(SUPER) / DUPLEX
380	Cuerpos superior e inferior de bomba	DIN	GG25 0.6025	GG25 0.6025	GG25 0.6025	G X6 CrNi19-10 1.4308	G X5 CrNiMo19-11-2 1.4408	(SUPER) / DUPLEX
381	Upper and bottom pump casings	ISO-EN	EN G.JL 250	EN G.JL 250	EN G.JL 250	G X5 CrNi19-10	G X5 CrNiMo19-11-2	
	Corps supérieur et inférieur de pompe	ASTM / AISI	A 278 Cl.30	A 278 Cl.30	A 278 Cl.30	A- 351-43-744 CF8/AISI 304	A-351-743-744 CF8M/AISI 316	
12	Aros cierre cuerpo de bomba	DIN	G CuSn10	G CuSn10	G CuSn10	G X5 CrNi19-10 1.4308	X10 CrNiMoTi 18-10	(SUPER) / DUPLEX
	Pump casing wear rings	ISO-EN				G X5 CrNi19-10		
	Bague d'usure corps de pompe	ASTM / AISI	B 143/61 1A-1B	B 143/61 1A-1B	B 143/61 1A-1B	A- 351-43-744 CF8/AISI 304	A-167 Tipo 316/AISI 316	
727	Rodete	DIN	GG25 0.6025	G CuSn10	G X5 CrNi19-10 1.4308	G X5 CrNi19-10 1.4308	G X5 CrNiMo19-11-2 1.4408	(SUPER) / DUPLEX
728	Impeller	ISO-EN	EN G.JL 250		G X5 CrNi19-10	G X5 CrNi19-10	G X5 CrNiMo19-11-2	
730	Roue	ASTM / AISI	A 278 Cl.30	B 143/61 1A-1B	A- 351-43-744 CF8/AISI 304	A- 351-43-744 CF8/AISI 304	A-351-743-744 CF8M/AISI 316	
445	Eje de bomba	DIN	X20 Cr13 1.4021	X20 Cr13 1.4021	X20 Cr13 1.4021	X20 Cr13 1.4021	X10 CrNiMoTi 18-10	(SUPER) / DUPLEX
	Pump shaft	ISO-EN	X20 Cr13	X20 Cr13	X20 Cr13	X20 Cr13	X 6 CrNiMoTi 17-12-2	
	Arbre de pompe	ASTM / AISI	A 276 Tipo 420/AISI 420	A 276 Tipo 420/AISI 420	A 276 Tipo 420/AISI 420	A 276 Tipo 420/ AISI 420	A-167 Tipo 316/AISI 316 Ti	
320	Casquillo prensa	DIN	X5 CrNi 18-9 1.4301	X5 CrNi 18-9 1.4301	X5 CrNi 18-9 1.4301	X10 CrNiMoTi 18-10	X10 CrNiMoTi 18-10	(SUPER) / DUPLEX
	Shaft sleeve	ISO-EN				X 6 CrNiMoTi 17-12-2	X 6 CrNiMoTi 17-12-2	
	Chemise d'arbre	ASTM / AISI	AISI 304	AISI 304	AISI 304	A-167 Tipo 316/AISI 316 Ti	A-167 Tipo 316/AISI 316 Ti	
302	Caja prensa anterior/posterior	DIN	GG25 0.6025	GG25 0.6025	GG25 0.6025	G X5 CrNi19-10 1.4308	G X5 CrNiMo19-11-2 1.4408	(SUPER) / DUPLEX
303	Packing box DE/NDE	ISO-EN	EN G.JL 250	EN G.JL 250	EN G.JL 250	G X5 CrNi19-10	G X5 CrNiMo19-11-2	
	Boite garniture anterior/posterior	ASTM / AISI	A 278 Cl.30	A 278 Cl.30	A 278 Cl.30	A- 351-43-744 CF8/AISI 304	A-351-743-744 CF8M/AISI 316	
787	Soporte rodamientos anterior/posterior	DIN	GG25 0.6025	GG25 0.6025	GG25 0.6025	GG25 0.6025	GG25 0.6025	(SUPER) / DUPLEX
788	Bearing housing DE/NDE	ISO-EN	EN G.JL 250	EN G.JL 250	EN G.JL 250	EN G.JL 250	EN G.JL 250	
	Corps palieur anterior/posterior	ASTM / AISI	A 278 Cl.30	A 278 Cl.30	A 278 Cl.30	A 278 Cl.30	A 278 Cl.30	
810	Tapa rodamiento anterior/posterior	DIN	GG25 0.6025	GG25 0.6025	GG25 0.6025	GG25 0.6025	GG25 0.6025	(SUPER) / DUPLEX
811	Bearing housing cover DE/NDE	ISO-EN	EN G.JL 250	EN G.JL 250	EN G.JL 250	EN G.JL 250	EN G.JL 250	
	Couvercle palieur anterior/posterior	ASTM / AISI	A 278 Cl.30	A 278 Cl.30	A 278 Cl.30	A 278 Cl.30	A 278 Cl.30	
	Estanqueidad		Prensa estopas	Prensa estopas	Prensa estopas	Cierre mecánico	Cierre mecánico	Cierre mecánico
	Shaft sealing		Packing gland	Packing gland	Packing gland	Mechanical seal	Mechanical seal	Mechanical seal
	Etanchéité		Presse-étoupe	Presse-étoupe	Presse-étoupe	Garniture mécanique	Garniture mécanique	Garniture mécanique
	Tomillería		Acero Cadmiado	Acero Cadmiado	Acero Cadmiado	Acero inoxidable AISI 304	Acero inoxidable AISI 316	(Super) Duplex
	Nuts and bolts		Cadmium plated steel	Cadmium plated steel	Cadmium plated steel	Stainless steel AISI 304	Stainless steel AISI 316	(Super) Duplex
	Visserie		Acier Cadmié	Acier Cadmié	Acier Cadmié	Acier inox AISI 304	Acier inox AISI 316	(Super) Duplex
			A+Cierre mecánico=A1	B+Cierre mecánico=B1	C+Cierre mecánico=C1		Cierre mecánico burgmann	
			A+Mechanical seal=A1	B+Mechanical seal=B1	C+Mechanical seal=C1		Mechanical seal burgmann	
			A+Gran. mecanique=A1	B+Gran. mecanique=B1	C+Gran. mecanique=C1		Gran. mecanique burgmann	



BOMBAS IDEAL, S.A. se reserva el derecho de variar datos y dimensiones de este catálogo sin previo aviso.
BOMBAS IDEAL, S.A. reserved the right to alter performance, specifications at any time without prior notice.
BOMBAS IDEAL, S.A. se reserve le droit de varier les renseignements et dimensions de ce catalogue sans préavis.

BOMBAS IDEAL, S.A.

Polígono Industrial Mediterráneo. Calle Cid, 8
Tel.: 34 961 402 143 - 902 203 400 - FAX: 34 96 140 21 31
Massalfassar - Valencia (Spain)
www.bombasideal.com

