



More durable and long lasting.

Fully automated motorized sliding barrier.

SLB220 series is an innovative pedestrian control technology that designed to achieve best balance of quality, performance and affordability.

SLB220 series provide a combination of reliable mechanical as well as electronic restriction for unauthorized visitor while still maintain a welcoming atmosphere. High door panel design prohibit attempt to climb over. Access control and time attendance reader can be integrated into sliding barrier.

SLB220 series is ideal indoor solution for lift lobby of commercial, industrial or government building. Elegant arc design and detailed hair line polishing effectively elleviate prestigious feeling of your building entrance.



SLB220

Features:

1 Minimum maintenance

Uses brushless DC motor eliminate the need of changing carbon brush thus reducing maintenance work. Key internal parts is treated with anti-rust and anti-septic to ensure long term reliability.

2 Higher security

Sliding barrier design with high door panel to prevent unauthorized visitor from gaining access by climbing over or crawling under the gate.

3 Elegant design

Premium stainless steel and glass panel material with elegant arc design effectively help create an welcoming and elegant prestigious atmosphere at building entrance to impress your visitors.

4 Anti tailgating

High performance IR sensor is used to detect tail-gating, illegal passing attempt and pass through direction to ensure maximum security at front gate. Door panel will be closed if tailgating is detected.

5 Emergency recovery

During power failure, door panel will open automatically to allow free pass through. In the event of emergency such as fire alarm, sliding barrier can be manually trigger to open permanently to allow fast evacuation.

Technical specification:

Description	Parameters
Power Input	AC220 ±10% V, 50Hz
Working Voltage	DC 24V
Motor	Brushless DC Servo Motor
Power consumption	100 W
Working Temperature	-20°C - 60°C
Humidity	≤90%, No Condensation
Open Signal	Passive signals (Dry contact signals)
Communication	RS485
Pass Rate	≤30 person / min
Passage Width	550 mm
Wing Panel	10mm thick tempered glass
IR sensor	14 pair of IR sensors
Housing Material	304 Stainless Steel

Dimension:

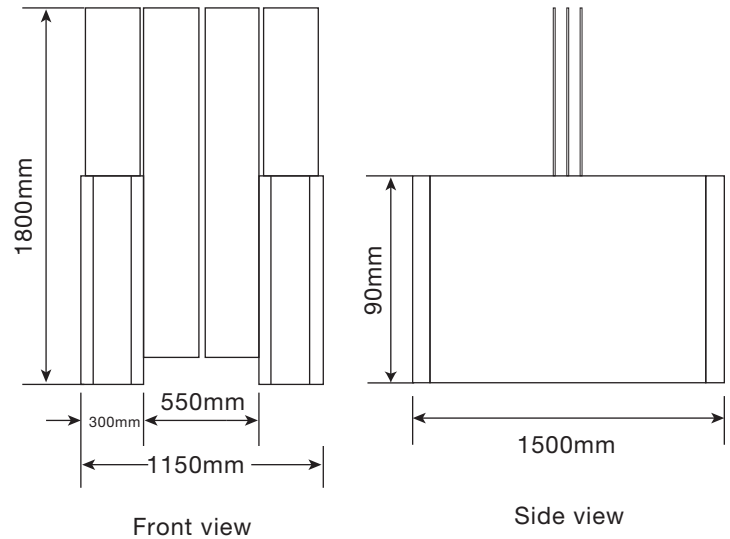

Accessories:



Push Button

Ordering info:

Model No	Description
SLB221	Single door panel
SLB222	Dual door panel



“ Entrance is the first level of protection in building security. MAG offer complete gate automation system to secure your entrance.... ”

Authorised Dealer:

All specification, drawing and product info are subject to change without prior notice.