

仕上加工用 刃先交換式ボールエンドミル

Indexable Ball End Mill for Finishing

アルファ ボールプレシジョン F **ABPF**

Ball Precision F ABPF



株式会社 **MOLDINO**
MOLDINO Tool Engineering, Ltd.

New Product News | No.0902-20 | 2023-6

S字の切れ味! 強ねじれ刃形による美しい加工面 コーナでもびびりにくい 高精度加工用インサート

High cutting performance by S-shaped cutting edge!
High helix edge shape provides a beautiful cutting surface.
Insert for high-accuracy machining suppresses chatter even in corners.

より強靱に

Tougher and Stronger

モジュラーミルタイプ エア穴付きを6アイテム 追加発売しました!

Introducing 6 Modular Mill Type with Air hole items!



HD7010	ATH10E	PN15M PN08M	ATH80D	TH303
グラファイト アルミニウム合金 Cast aluminum alloys	鋳鉄 Cast irons	炭素鋼 合金鋼 Alloy steels	ステンレス鋼 Stainless steels	プリハードン鋼 Pre-hardened steels
			焼入れ鋼 45~55HRC	焼入れ鋼 55~62HRC
			Hardened steels 45-55HRC	Hardened steels 55-62HRC

加工用途
Applications

金型製作
Mold making

部品加工
Parts processing

特長 01 取付けR精度±0.01mm

Features

Set up R accuracy : ±0.01mm

- ボール部先端から外周まで、高いR精度を示します。
・ High accuracy is exhibited from the ball tip to the outer circumference.

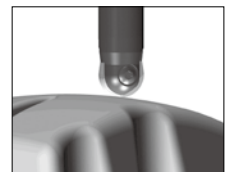

特長 02 優れた切れ味、きれいな仕上げ面

Features

Excellent cutting performance and beautiful cutting surface finish.

- 強ねじれ刃形による切削抵抗低減により優れた仕上げ面粗さが得られます。
・ High helix edge shape suppresses growth of cutting force.

特長 03 新材種により長寿命

Features

New material for longer life.

- マルチレイヤーコーティングにより長寿命です。
・ Multi-layer coating provides long life.

※切削性能に関する詳細は、P18 をご参照下さい。 ※For details regarding cutting performance, see p.18.

強ねじれ刃形インサートがもたらす効果 An effect by high helix edge shape

従来起きやすかった問題 Typical conventional problem

R寸法に近い形状を加工すると、びびりが生じやすいという問題がありました。切削抵抗が増すことによって、工具は激しく振動します。そのために加工面にびびりマークがついてしまいます。

Chattering happened frequently while cutting R-shape or similar. The more the cutting force, the more the chattering which makes cutting mark on the work surface.



加工時の切削抵抗を緩和 Reduce cutting force

強ねじれ刃形を採用したことで、切削抵抗の急激な上昇を抑えることができました。それにより、加工時のびびりを抑えることができ、仕上げ面性状が向上しました。

High helix edge shape suppresses rapid growth of cutting force. This relieves chattering while cutting and improves cutting surface finish.



- 仕上げ面性状が改善されました。 · Improved cutting surface finish.
- コーナでもびびりにくい。 · Less chattering on corner.

メリット Merit

加工能率と加工精度の向上が見込め、後工程の工数を減らせます。
Improved machining performance and machining accuracy can be expected, reducing work for downstream processes.

品質向上
Improved quality

コスト削減
Cost reduction

時間短縮
Time savings

工具寿命も延長 Improved tool life

切削抵抗を抑制できたことで、摩耗や衝撃からくるチッピングを減らすことができました。それにより、工具寿命も大幅に改善しました。

Less cutting force reduces chipping due to wear and impact, thus tool life is improved.

強ねじれ刃形インサートの使い分け Recommended grades map

被削材硬度を考慮した選択方法

Recommendation of based on hardness of work materials

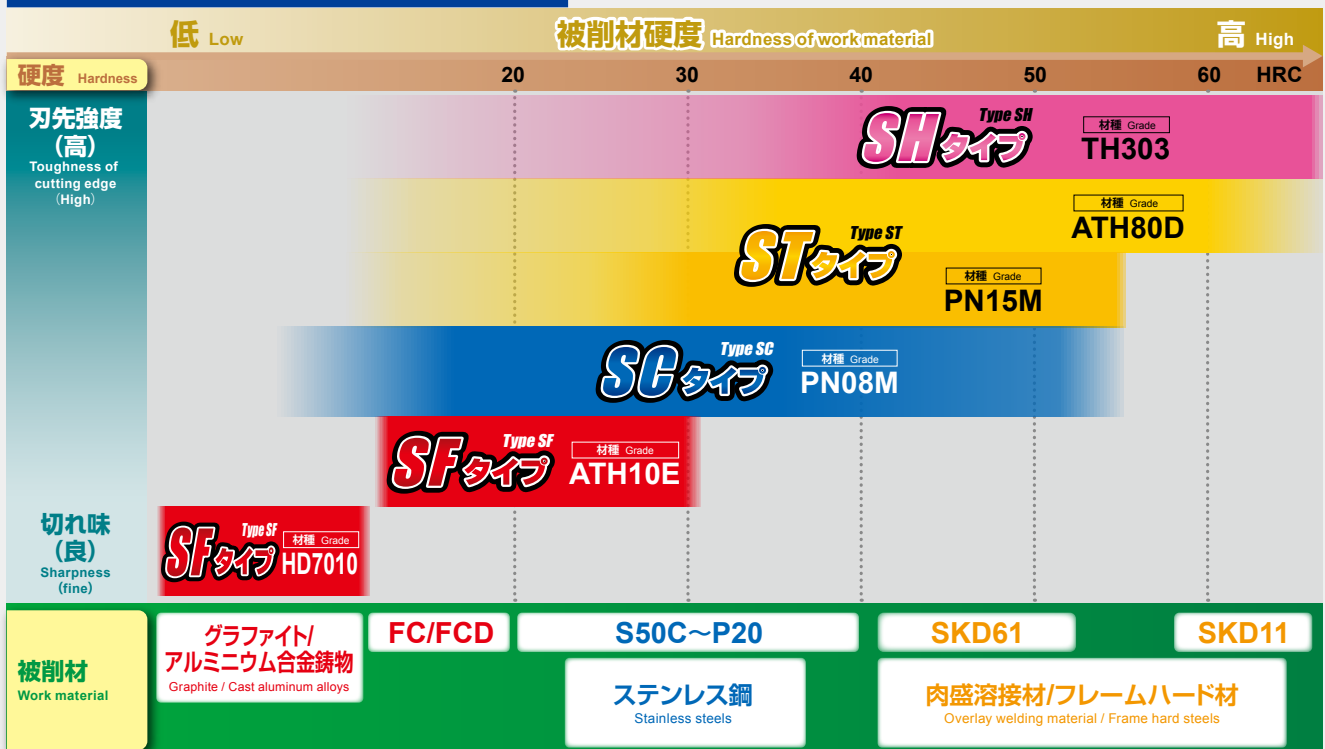

PVD Technology TH3コーティング TH303

TH3 Coating

○ 特長 Features

- TH系コーティングが進化した第3世代の新THコーティング。
- 新しい膜組成と膜構造により耐熱性と耐摩耗性が向上。
- 新マルチレイヤー構造は靱性に優れ、クラックの進行を抑制します。
 - ・ TH Coating has further evolved to the new 3rd-generation TH Coating.
 - ・ New film composition and film structure improves heat resistance and wear resistance.
 - ・ New multi-layer structure provides excellent durability and suppresses crack progression.

○ 得意分野 Strong fields

- 焼入れ鋼(45~65HRC) : SKD11, SKD61, SKH, SUS420系等の高速仕上げ加工。
- プリハードン鋼: P20, P21等の高速仕上げ加工。
- TH303は、耐摩耗性に優れた超微粒超硬合金とTH3コーティングの採用により、特に高硬度材の仕上げ加工において性能を発揮します。
 - ・ High-speed finishing of hardened steels (45 to 65 HRC) such as SKD11, SKD61, SKH, SUS420 types, etc.
 - ・ High-speed finishing of pre-hardened steels such as P20, P21, etc.
 - ・ TH308 uses ultra-fine carbide alloy with excellent wear resistance and TH3 Coating to demonstrate good performance especially for finishing of high-hardness materials.

○ 機能 Characteristics

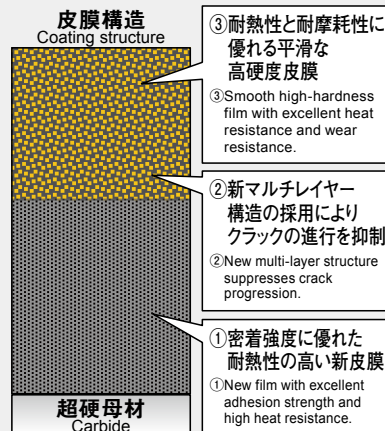

PVD Nano Technology スーパーコーティング PN

Super Coating "Panacea Technology"

○ 特長 Features

- マルチレイヤー構造の採用により、密着強度、皮膜硬度の向上及び耐酸化温度の向上を実現しました。
- 摩擦係数のさらなる改善により切削加工時における発熱が少なく、ドライ加工にも対応できます。
 - ・ Industry's first multi-layer structure provides improved adhesion and membrane hardness as well as improving the oxidation-resistance temperature.
 - ・ PN coating Improve the friction coefficient, reduces generation of heat on cutting.

○ 得意分野 Strong fields

- プラスチック金型などの工具への溶着が起こりやすい材料の切削に対して、良好な切削寿命を示します。炭素鋼、プリハードン鋼、合金鋼、SUS系、SKD61などの切削加工で長寿命です。
- PN08Mは、摩耗性に優れた超微粒子超硬合金素材とPNコーティングの組み合わせにより、プラスチック金型(炭素鋼~プリハードン鋼)の仕上げ加工に性能を発揮します。
- PN15Mは、耐欠損性の高い超微粒子超硬合金素材とPNコーティングの組み合わせにより、工具突出しの長い加工(L/D:5以上)や、削り代が不均一な加工に対して性能を発揮します。
 - ・ Exhibits stable tool life in cutting materials such as plastic injection molds etc. where tool seizure often occurs. Realizes longer tool life in cutting prehardened steels such as carbon steels, alloy steels, stainless steels, hot and cold tool steel, etc.
 - ・ PN08M adopts micro-grain substrate and PN Coating. Improve the cutting performance for plastic injection mold finishing.
 - ・ PN15M adopts micro-grain substrate and PN Coating. Improve the cutting performance for overhang cutting.

○ 機能 Characteristics

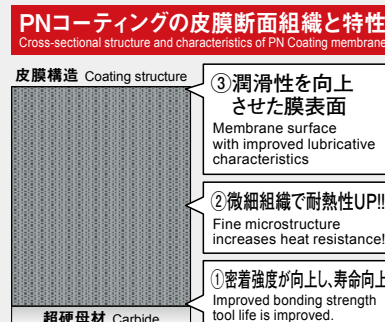

High adhesion Diamond Coating ダイヤモンドコーティング HD

Diamond Coating

○ 機能 Characteristics

- 結晶性のよいダイヤモンドを採用。グラファイトや高Siアルミニウム合金、繊維強化プラスチック(FRP)の切削加工に適します。
- 独自の前処理技術を採用。アンカー効果により密着性向上
- 母材にはダイヤモンドコーティング専用材種を採用
 - ・ Uses diamond with good crystallization. Ideal for cutting of graphite, high-silicon aluminum alloys and fiber-reinforced plastics (FRP).
 - ・ Our exclusive pre-treatment technology is used to provide higher adhesion due to anchor effect.
 - ・ Special material for Diamond Coating is adopted for base metal.

グラファイト加工事例 (HD7010) Machining example of Graphite

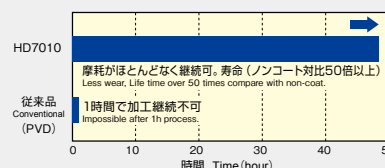

切削条件 Cutting conditions
 ボディ Cutter Body : ABPF10S10WL140(φ10)
 $v_c=200\text{m/min}$ $n=6.370\text{min}^{-1}$
 $v_f=2,500\text{mm/min}$ ($f_z=0.2\text{mm/t}$)
 $ap \times ae=0.5 \times 0.3\text{mm}$ 乾式 Dry

ラインナップ

Line Up

強ねじれ刃形インサート

High helix edge shape inserts

P	鋼 Carbon steels					■: 一般切削・第一推奨 General cutting, First recommendation											
	K																
FC・FCD Cast irons					□: 一般切削・第二推奨 General cutting, Second recommendation												
N																	
グラファイト Graphite					■: 一般切削・第一推奨 General cutting, First recommendation												
アルミニウム合金 Aluminum alloys																	
H					□: 一般切削・第二推奨 General cutting, Second recommendation												
高硬度材 Hardened steels																	
形状 Shape	商品コード Item code	公差 Tolerance class	コーティング Coating					寸法 Size(mm)					形状 Shape	希望小売価格(円) Suggested retail price (¥)			
			TH303	ATH80D	ATH10E	PN08M	PN15M	HD7010	RE	LE	INSL	DC		T	TH303 ATH80D ATH10E PN08M PN15M	HD7010	
<p>Fig.1</p>	SH タイプ Type SH	F級	●						3	3	5	6	2	Fig.1	4,490	—	
			●						4	4.4	9.7	8	2.1		5,050	—	
			●						5	5.6	12.1	10	2.7		7,020	—	
			●						6	6.6	14.6	12	3.2		7,440	—	
			●						8	9	16.6	16	4.2		7,640	—	
			●						10	11.5	20.3	20	5.2		8,060	—	
			●						12.5	14.5	24.1	25	6.2		8,550	—	
			●						15	18.5	29.2	30	7.2		11,020	—	
	<p>Fig.2</p>	ST タイプ Type ST	F級	●					3	3	5	6	2	Fig.1	4,490	—	
				●						4	4.4	9.7	8		2.1	5,050	—
				●						5	5.6	12.1	10		2.7	7,020	—
				●						6	6.6	14.6	12		3.2	7,440	—
				●						8	9	16.6	16		4.2	7,640	—
				●						10	11.5	20.3	20		5.2	8,060	—
●									12.5	14.5	24.1	25	6.2		8,550	—	
●									15	18.5	29.2	30	7.2		11,020	—	
<p>Fig.1</p>	SC タイプ Type SC	F級		●				3	3	5	6	2	Fig.1	4,490	—		
				●					4	4.4	9.7	8		2.1	5,050	—	
				●					5	5.6	12.1	10		2.7	7,020	—	
				●					6	6.6	14.6	12		3.2	7,440	—	
				●					8	9	16.6	16		4.2	7,640	—	
				●					10	11.5	20.3	20		5.2	8,060	—	
				●					12.5	14.5	24.1	25		6.2	8,550	—	
				●					15	18.5	29.2	30		7.2	11,020	—	
	<p>Fig.2</p>	SF タイプ Type SF	F級					●※	3	3	5	6	2	Fig.1	—	23,350	
								●※	4	4.4	9.7	8	2.1		—	26,260	
								●※	5	5.6	12.1	10	2.7		—	37,590	
								●※	6	6.6	14.6	12	3.2		—	41,520	
						●		●※	8	9	16.6	16	4.2		7,640	44,100	
						●		●※	10	11.5	20.3	20	5.2		8,060	46,690	
					●		●※	12.5	14.5	24.1	25	6.2	8,550		—		
					●		●※	15	18.5	29.2	30	7.2	11,020		—		

※印: HD7010は再研磨不可です。HD7010以外のφ10以上のインサートは再研磨が可能です。φ16以上では最大2回まで再研磨が可能です。
 ※mark: Regrinding of HD7010 tools cannot be performed. Inserts other than HD7010 with diameters of φ10 or more can be regrinded. Insert φ16 or above may be re-ground up to twice.

インサートの再研磨&再コーティングも承っております。詳しくは弊社営業所までお問い合わせください。 Please inquire insert re-grinding / re-coating to sales office.

インサート取付け手順

Set-up procedures of Inserts

- 1** インサート座面の清掃
 エアブローなどで、インサート座面を清掃ください。
 Clean the insert seat:
 Using air-blow or alike, clean the seat.
- 2** インサートは、上面を工具本体のねじ締め付け側に合わせ、挿入する。
 Put in the insert with its top positioned to the screw-tightening side of the tool body.
- 3** 専用レンチにてクランプねじを締め付ける。
 この時インサートは押さえつけないでください。
 Tighten the clamp screw with the special wrench.
 Please do not press down the insert during this tightening process.
- 4** 締め付け完了。
 This is the end of insert set-up.

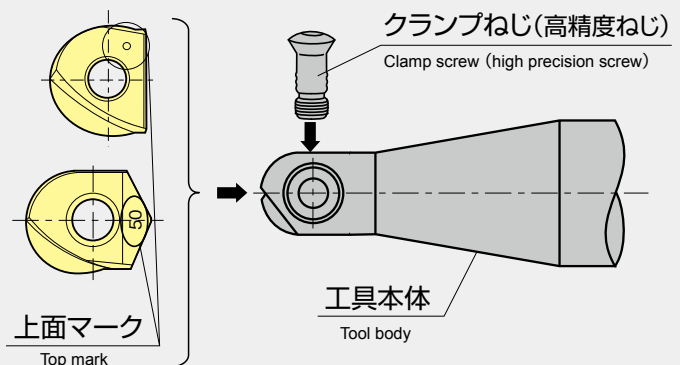

取り付け精度R公差:±0.01mmを満足するため、左記手順に従ってください。
 To meet the specification for precision of ±0.01mm, please follow this procedure.

ご注意

Attention

インサートを挿入しない状態でのクランプねじ締結は、ホルダー本体の変形に繋がる恐れがあり、インサートの取り付け不良や取付精度の劣化につながる可能性があるため決して行わないでください。
 Never tighten the clamp screw without putting the insert. The tool body may be deformed, resulting in improper insert mounting or deterioration of mounting accuracy.



インサート未挿入での空締め禁止
 Do not tighten the screw without putting insert

鋼シャンク

Steel Shank

ABPF○○S○○(L/L○○○)

○は数字、□は英文字が入ります。 Numeric figure in a circle ○ and Alphabetical character comes in a square □

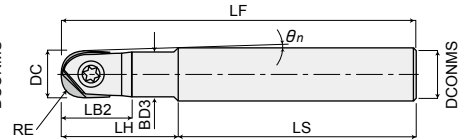
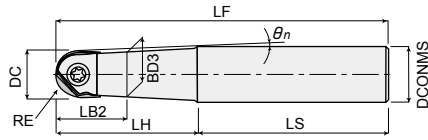

Aタイプ(首下テーパ) Type A (Taper neck)

Bタイプ(首下ストレート) Type B (Straight neck)

	商品コード Item code	在庫 Stock	インサート数 No. of inserts	寸法 Size (mm)								形状 Shape	適用インサート Inserts	希望小売 価格(円) Suggested retail price(¥)	
				DC	RE	LF	DCONMS	LB2	LH	BD3	LS				θ_n
Regular	ABPF06S10	●	1	6	3	80	10	15	30	5.4	50	4.3°	A	ZPFG06N-SH ZDFG06N-S□	15,730
	ABPF08S12	●	1	8	4	100	12	10	22	7.5	78	6.4°	A	ZPFG080-SH ZDFG080-S□	18,430
	ABPF10S12	●	1	10	5	100	12	13	25	9.5	75	2.9°	A	ZPFG100-SH ZDFG100-S□	19,240
	ABPF12S12	●	1	12	6	110	12	15	30	11.5	80	—	B	ZPFG120-SH ZDFG120-S□	20,070
	ABPF16S20	●	1	16	8	130	20	27	50	15	80	2.8°	A	ZPFG160-SH ZDFG160-S□	23,350
	ABPF20S25	●	1	20	10	140	25	35	60	19	80	2.9°	A	ZPFG200-SH ZDFG200-S□	26,870
	ABPF25S32	●	1	25	12.5	150	32	43	70	24	80	3.5°	A	ZPFG250-SH ZDFG250-S□	41,060
	ABPF30S32	●	1	30	15	160	32	55	80	29	80	1.2°	A	ZPFG300-SH ZDFG300-S□	41,060
	ABPF32S32	●	1	32	16	160	32	58	80	31	80	—	B	ZPFG320(-G□) ZDFG320-W□	41,060
Under neck long	ABPF08S12L	●	1	8	4	130	12	10	50	7.5	80	2.5°	A	ZPFG080-SH ZDFG080-S□	24,520
	ABPF10S16L	●	1	10	5	150	16	13	50	9.5	100	3.9°	A	ZPFG100-SH ZDFG100-S□	27,110
	ABPF12S16L	●	1	12	6	160	16	15	60	10.8	100	2.2°	A	ZPFG120-SH ZDFG120-S□	27,570
	ABPF16S20L	●	1	16	8	160	20	27	65	15	95	2.1°	A	ZPFG160-SH ZDFG160-S□	29,570
	ABPF20S25L	●	1	20	10	180	25	35	80	19	100	2.1°	A		34,730
	ABPF20S20L120	●	1	20	10	220	20	35	120	19	100	—	B	ZPFG200-SH ZDFG200-S□	32,260
	ABPF20S20L150	●	1	20	10	250	20	35	150	19	100	—	B		32,260
	ABPF25S32L	●	1	25	12.5	200	32	43	90	24	110	2.6°	A		49,270
	ABPF25S32L150	●	1	25	12.5	250	32	43	150	24	100	1.5°	B	ZPFG250-SH ZDFG250-S□	49,270
	ABPF30S32L	●	1	30	15	220	32	55	100	29	120	0.7°	A		49,270
	ABPF30S32L150	●	1	30	15	250	32	55	150	29	100	0.5°	B	ZPFG300-SH ZDFG300-S□	49,270
ABPF30S32L200	●	1	30	15	300	32	55	200	29	100	0.3°	B		49,270	
ABPF32S32L	●	1	32	16	220	32	58	100	31	120	—	B	ZPFG320(-G□) ZDFG320-W□	49,270	

ABPF○○MT○○

○は数字、□は英文字が入ります。 Numeric figure in a circle ○ and Alphabetical character comes in a square □

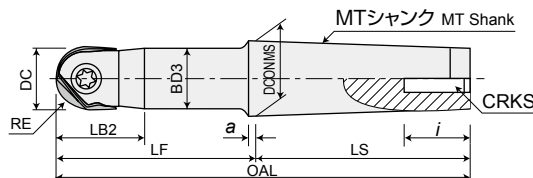

商品コード Item code	在庫 Stock	インサート数 No. of inserts	寸法 Size (mm)											適用インサート Inserts	希望小売 価格(円) Suggested retail price(¥)	
			DC	RE	MT番号 MT No.	OAL	LB2	LF	LS	DCONMS	BD3	a	i			CRKS
ABPF20MT2	●	1	20	10	MT2	129	35	65	64	17.78	19	5	24	M10	ZPFG200-SH ZDFG200-S□	40,240
ABPF25MT3	●	1	25	12.5	MT3	166	43	85	81	23.825	24	5	28	M12	ZPFG250-SH ZDFG250-S□	53,960
ABPF30MT4	●	1	30	15	MT4	217.5	55	115	102.5	31.267	29	6.5	32	M16	ZPFG300-SH ZDFG300-S□	64,060
ABPF32MT4	●	1	32	16	MT4	217.5	58	115	102.5	31.267	31	6.5	32	M16	ZPFG320(-G□) ZDFG320-W□	64,060

ラインナップ

Line Up

超硬シャンク

Carbide Shank

ABPF○○S○○W (□/□○○○)

○は数字、□は英文字が入ります。
Numeric figure in a circle ○ and
Alphabetical character comes in a square □.

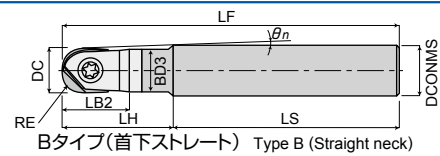
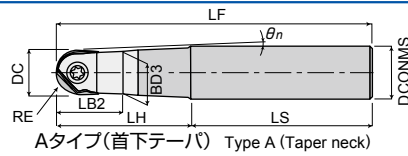

商品コード Item code	在庫 Stock	インサート数 No. of inserts	寸法 Size (mm)									形状 Shape	適用インサート Inserts	希望小売 価格(円) Suggested retail price(¥)	
			DC	RE	LF	DCONMS	LB2	LH	BD3	LS	θ_n				
ABPF06S06W	●	1	6	3	90	6	10.3	25	5.5	65	—	B	ZPFG06N-SH	34,960	
ABPF06S06WL65	●	1	6	3	120	6	10.3	65	5.5	55	—	B	ZDFG06N-S□	35,910	
ABPF08S08W-90-25	●	1	8	4	90	8	25	25	7.5	65	—	B	ZPFG080-SH ZDFG080-S□	42,700	
ABPF08S08W	●	1	8	4	100	8	30	30	7.5	70	—	B		43,410	
ABPF08S08W-115-50	●	1	8	4	115	8	50	50	7.5	65	—	B		44,120	
ABPF08S08WL	●	1	8	4	130	8	65	65	7.5	65	—	B		45,290	
ABPF08S08W-140-75	●	1	8	4	140	8	75	75	7.5	65	—	B		45,750	
ABPF08S08WL95	●	1	8	4	160	8	95	95	7.5	65	—	B		47,170	
ABPF08S08W-175-110	●	1	8	4	175	8	110	110	7.5	65	—	B		51,620	
ABPF08S12WLT75	●	1	8	4	140	12	14	75	7.5	65	1.62°	A		—	
ABPF10S10W-90-25	●	1	10	5	90	10	18	25	9.5	65	—	B		ZPFG100-SH ZDFG100-S□	44,820
ABPF10S10W	●	1	10	5	100	10	18	35	9.5	65	—	B			45,050
ABPF10S10W-115-50	●	1	10	5	115	10	18	50	9.5	65	—	B	48,930		
ABPF10S10WL	●	1	10	5	140	10	18	75	9.5	65	—	B	49,510		
ABPF10S10WL95	●	1	10	5	160	10	18	95	9.5	65	—	B	51,740		
ABPF10S10W-185-120	●	1	10	5	185	10	18	120	9.5	65	—	B	56,440		
ABPF10S10WL140	●	1	10	5	220	10	18	140	9.5	80	—	B	58,420		
ABPF10S12WLT75	●	1	10	5	140	12	18	75	9.5	65	0.82°	A	—		
ABPF12S12W-95-30	●	1	12	6	95	12	21	30	11.5	65	—	B	ZPFG120-SH ZDFG120-S□		55,020
ABPF12S12W	●	1	12	6	110	12	21	45	11.5	65	—	B			56,780
ABPF12S12W-125-60	●	1	12	6	125	12	21	60	11.5	65	—	B		57,140	
ABPF12S12WL	●	1	12	6	150	12	21	85	11.5	65	—	B		59,600	
ABPF12S12WL100	●	1	12	6	200	12	21	100	11.5	100	—	B		61,470	
ABPF12S12WL120	●	1	12	6	200	12	21	120	11.5	80	—	B		61,470	
ABPF12S12WL150	●	1	12	6	220	12	21	150	11.5	70	—	B		64,520	
ABPF12S16WLT85	●	1	12	6	150	16	21	85	11.5	65	1.45°	A		—	
ABPF16S16W-105-35	●	1	16	8	105	16	27	35	15	70	—	B		ZPFG160-SH ZDFG160-S□	61,940
ABPF16S16W-120-50	●	1	16	8	120	16	27	50	15	70	—	B			69,340
ABPF16S16W60	●	1	16	8	130	16	27	60	15	70	—	B	70,380		
ABPF16S16WL80	●	1	16	8	160	16	27	80	15	80	—	B	75,900		
ABPF16S16WL100	●	1	16	8	200	16	27	100	15	100	—	B	82,240		
ABPF16S16WE	●	1	16	8	200	16	27	120	15	80	—	B	82,240		
ABPF16S16WE150	●	1	16	8	220	16	27	150	15	70	—	B	87,980		
ABPF16S16W-250-180	●	1	16	8	250	16	27	180	15	70	—	B	99,950		
ABPF16S20WLT100	●	1	16	8	165	20	27	100	15	65	1.25°	A	—		
ABPF20S20W-120-40	●	1	20	10	120	20	35	40	19	80	—	B	ZPFG200-SH ZDFG200-S□		78,250
ABPF20S20W-140-60	●	1	20	10	140	20	35	60	19	80	—	B		85,290	
ABPF20S20W80	●	1	20	10	160	20	35	80	19	80	—	B		93,380	
ABPF20S20WL100	●	1	20	10	220	20	35	100	19	120	—	B		106,520	
ABPF20S20WL120	●	1	20	10	220	20	35	120	19	100	—	B		106,520	
ABPF20S20WE	●	1	20	10	250	20	35	150	19	100	—	B		113,080	
ABPF20S20W-270-190	●	1	20	10	270	20	35	190	19	80	—	B		117,300	
ABPF20S20WE220	●	1	20	10	300	20	35	220	19	80	—	B		124,340	
ABPF20S25WLT115	●	1	20	10	195	25	35	115	19	80	1.37°	A		—	
ABPF25S25W-130-50	●	1	25	12.5	130	25	43	50	24	80	—	B		ZPFG250-SH ZDFG250-S□	113,670
ABPF25S25W-160-80	●	1	25	12.5	160	25	43	80	24	80	—	B	123,170		
ABPF25S25W100	●	1	25	12.5	220	25	43	100	24	120	—	B	132,550		
ABPF25S25WL120	●	1	25	12.5	220	25	43	120	24	100	—	B	132,550		
ABPF25S25WL150	●	1	25	12.5	250	25	43	150	24	100	—	B	151,320		
ABPF25S25WE	●	1	25	12.5	300	25	43	190	24	110	—	B	170,090		
ABPF25S25W-300-220	●	1	25	12.5	300	25	43	220	24	80	—	B	170,090		
ABPF25S32WLT135	●	1	25	12.5	215	32	43	135	24	80	1.64°	A	—		
ABPF30S32W-160-80	●	1	30	15	160	32	55	80	29	80	—	B	ZPFG300-SH ZDFG300-S□		156,010
ABPF30S32W100	●	1	30	15	180	32	55	100	29	80	0.7°	B			158,360
ABPF30S32W120	●	1	30	15	220	32	55	120	29	100	0.6°	B		190,030	
ABPF30S32WL150	●	1	30	15	250	32	55	150	29	100	0.4°	B		202,930	
ABPF30S32W-260-180	●	1	30	15	260	32	55	180	29	80	—	B		205,280	
ABPF30S32W-290-210	●	1	30	15	290	32	55	210	29	80	—	B		228,740	
ABPF30S32WE	●	1	30	15	350	32	55	230	29	120	0.3°	B		267,450	
ABPF30S32WLT160	●	1	30	15	240	32	55	160	29	80	0.4°	A		—	
ABPF32S32W120	●	1	32	16	200	32	58	120	31	80	—	B		ZPFG320(-G□) ZDFG320-W□	171,260
ABPF32S32WL150	●	1	32	16	250	32	58	150	31	100	—	B			208,800
ABPF32S32WE220	●	1	32	16	300	32	58	220	31	80	—	B	235,780		

ABPFU (アンダーネックタイプ) Under neck type

○は数字、□は英文字が入ります。
Numeric figure in a circle and Alphabetical character comes in a square

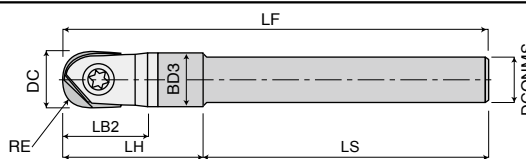

商品コード Item code	在庫 Stock	インサート数 No. of inserts	寸法 Size (mm)								適用インサート Inserts		希望小売 価格(円) Suggested retail price(¥)
			DC	RE	LF	DCONMS	LB2	LH	BD3	LS			
ABPFU16W220	●	1	16	8	220	15	27	39	15	181	ZPFG160-SH	ZDFG160-S	81,180
ABPFU20W270	●	1	20	10	270	18	35	51	19	219	ZPFG200-SH	ZDFG200-S	107,330
ABPFU25W300	●	1	25	12.5	300	23	43	61	24	239	ZPFG250-SH	ZDFG250-S	161,880
ABPFU30W300	●	1	30	15	300	28	55	73	29	227	ZPFG300-SH	ZDFG300-S	232,260

モジュラーミルタイプ Modular Mill Type

ABPFM

○は数字、□は英文字が入ります。
Numeric figure in a circle and Alphabetical character comes in a square

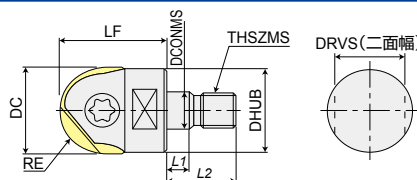

商品コード Item code	在庫 Stock	インサート数 No. of inserts	寸法 Size (mm)											適用インサート Inserts		希望小売 価格(円) Suggested retail price(¥)
			DC	RE	LF	DCONMS	THSZMS	DHUB	L1	L2	DRVS					
ABPFM10	●	1	10	5	26	6.5	M6	9.8	5.5	14.5	7	ZPFG100-SH	ZDFG100-S	19,240		
ABPFM12	●	1	12	6	26	6.5	M6	9.8	5.5	14.5	7	ZPFG120-SH	ZDFG120-S	20,070		
ABPFM16	●	1	16	8	32	8.5	M8	12.8	5.5	17	10	ZPFG160-SH	ZDFG160-S	23,350		
ABPFM20	●	1	20	10	38	10.5	M10	17.8	5.5	19	15	ZPFG200-SH	ZDFG200-S	26,870		
ABPFM25	●	1	25	12.5	38	12.5	M12	20.8	5.5	22	17	ZPFG250-SH	ZDFG250-S	41,060		
ABPFM30	●	1	30	15	43	17	M16	28.8	6	23	22	ZPFG300-SH	ZDFG300-S	41,060		
ABPFM32	●	1	32	16	43	17	M16	28.8	6	23	22	ZPFG320(-G)	ZDFG320-W	41,060		

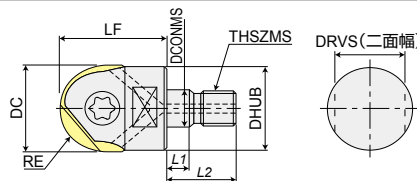

エア穴付き
With air hole

商品コード Item code	在庫 Stock	インサート数 No. of inserts	寸法 Size (mm)											適用インサート Inserts		希望小売 価格(円) Suggested retail price(¥)
			DC	RE	LF	DCONMS	THSZMS	DHUB	L1	L2	DRVS					
ABPFM10-M6H	●	1	10	5	26	6.5	M6	9.8	5.5	14.5	7	ZPFG100-SH	ZDFG100-S	21,120		
ABPFM12-M6H	●	1	12	6	26	6.5	M6	9.8	5.5	14.5	7	ZPFG120-SH	ZDFG120-S	22,060		
ABPFM16-M8H	●	1	16	8	32	8.5	M8	12.8	5.5	17	10	ZPFG160-SH	ZDFG160-S	25,700		
ABPFM20-M10H	●	1	20	10	38	10.5	M10	17.8	5.5	19	15	ZPFG200-SH	ZDFG200-S	29,570		
ABPFM25-M12H	●	1	25	12.5	38	12.5	M12	20.8	5.5	22	17	ZPFG250-SH	ZDFG250-S	45,170		
ABPFM30-M16H	●	1	30	15	43	17	M16	28.8	6	23	22	ZPFG300-SH	ZDFG300-S	45,170		

[注意] モジュラーミル及び専用シャンク、専用アーバの「工具端面」「モジュラーネジ部」にグリースなどの潤滑剤は塗布しないでください。
[Note] Do not apply lubricants such as grease, etc. to the "contact faces" and "modular screws" of the "modular mill", "dedicated shanks" and "dedicated arbor".

モジュラーミル専用シャンク

The Shanks for Modular Mill

超硬シャンク Carbide Shank

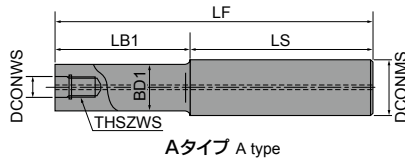

Aタイプ A type

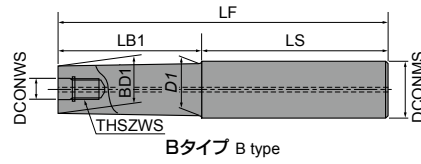

Bタイプ B type

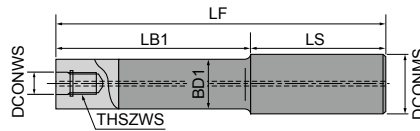

Cタイプ C type

商品コード Item code	在庫 Stock	寸法 Size (mm)							タイプ Type	適用カッタ Cutter body	エアーク 有無 With/ without air hole	希望小売 価格(円) Suggested retail price (¥)		
		DCONWS	THSZWS	LF	LB1	LS	BD1	DCONMS					D1	
ASC10-6.5-74-24Z	●	6.5	M6	74	24	50	9.3	10	-	A	φ10	○	25,810	
ASC10-6.5-84-34Z	●			84	34	50							27,930	
ASC10-6.5-114-49Z	●			114	49	65							30,270	
ASC10-6.5-114-24Z	●			24	90	30,270								
ASC12-6.5-74-24Z	●	6.5	M6	74	24	50	11	12	11.5	B	φ10 φ12	○	36,020	
ASC12-6.5-94-44Z	●			94	44	50							37,430	
ASC12-6.5-129-64Z	●			129	64	65							39,540	
ASC12-6.5-129-24Z	●			24	105	39,540								
ASC16-8.5-95-30Z	●	8.5	M8	95	30	65	14.5	16	15.5	B	φ16	○	48,100	
ASC16-8.5-120-55Z	●			120	55	65							52,560	
ASC16-8.5-140-75Z	●			140	75	65							55,960	
ASC16-8.5-160-95Z	●			160	95	65							58,900	
ASC16-8.5-160-30Z	●	160	30	130	58,900									
ASC20-10.5-120-50Z	●	10.5	M10	120	50	70	18.5	20	19.5	B	φ20	○	56,780	
ASC20-10.5-170-90Z	●			170	90	80							63,590	
ASC20-10.5-220-120Z	●			220	120	100							69,920	
ASC20-10.5-270-150Z	●			270	150	120							88,690	
ASC20-10.5-220-50Z	●	10.5	M10	220	50	170	18.5	20	19.5	B	φ20	○	69,920	
ASC20-10.5-270-50Z	●			270									220	88,690
ASC25-12.5-145-65	●	12.5	M12	145	65	80	23	25	-	C	φ25	○	64,990	
ASC25-12.5-215-115	●			215	115	100							76,130	
ASC25-12.5-265-145	●			265	145	120							88,690	
ASC25-12.5-315-195	●			315	195	120							114,370	
ASC25-12.5-265-65	●	12.5	M12	265	65	200	23	25	-	C	φ25	○	88,690	
ASC25-12.5-315-65	●			315									250	114,370
ASC32-17-160-80	●	17	M16	160	80	80	28	32	-	C	φ32	○	98,540	
ASC32-17-210-110	●			210	110	100							99,710	
ASC32-17-260-140	●			260	140	120							118,480	
ASC32-17-310-190	●			310	190	120							160,710	
ASC32-17-360-240	●	360	240	120	202,930									
ASC32-17-260-80	●	17	M16	260	80	180	28	32	-	C	φ32	○	118,480	
ASC32-17-310-80	●			310									230	160,710
ASC32-17-360-80	●			360									280	202,930

【注意】市販のミーリングチャック、焼ばめホルダーにて使用できます。【Note】Commercial milling chucks or shrink-fit holders can be used.

モジュラーミル専用シャンク

The Shanks for Modular Mill

鋼シャンク Steel Shank

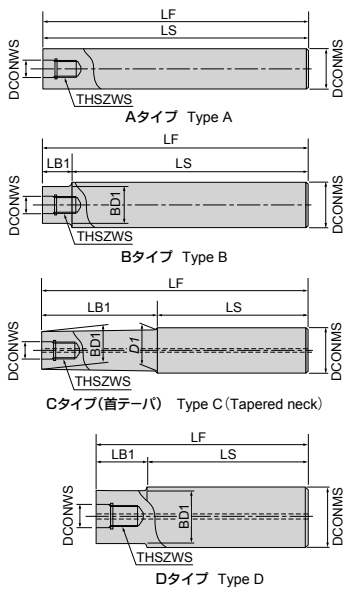

商品コード Item code	在庫 Stock	寸法 Size (mm)								形状 Shape	適用カッタ Cutter body	希望小売 価格(円) Suggested retail price(¥)
		DCONWS	THSZWS	LF	LB1	LS	BD1	DCONMS	D1			
AS10-6.5-74-0	●	6.5	M6	74	—	74	—	10	—	A	φ10	20,890
AS12-6.5-84-4	●	6.5	M6	84	4	80	11	12	—	B	φ12	24,290
AS16-8.5-95-15	●	8.5	M8	95	15	80	14.5	16	15.5	C	φ16	28,160
AS20-10.5-100-20	●	10.5	M10	100	20	80	18	20	—	D	φ20	31,680
AS25-12.5-115-35	●	12.5	M12	115	35	80	23	25	—	D	φ25	35,440
AS32-17-110-30	●	17	M16	110	30	80	28	32	—	D	φ30 φ32	42,470

【注意】市販のミーリングチャックにて使用できます。【Note】Commercial milling chucks can be used.

鋼シャンク Steel Shank

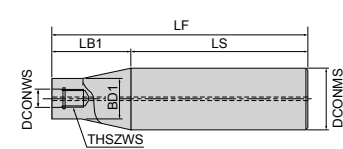

商品コード Item code	在庫 Stock	寸法 Size (mm)							適用カッタ Cutter body	希望小売 価格(円) Suggested retail price(¥)
		DCONWS	THSZWS	LF	LB1	LS	BD1	DCONMS		
AS42-17-360-90	●	17	M16	360	90	270	28	42	φ30 φ32	80,940

【注意】市販のミーリングチャックにて使用できます。【Note】Commercial milling chucks can be used.

部品番号

Parts

○は数字が入ります。
Numeric figure in a circle ○.

部品名 Parts	形状 Shape	クランプねじ Clamp screw		ドライバー/レンチ Screw driver / Wrench			ねじ焼き付き防止剤 Screw anti-seizure agent		
		締付トルク Fastening torque (N·m)	希望小売 価格(円) Suggested retail price (¥)	形状 Shape	希望小売 価格(円) Suggested retail price (¥)	形状 Shape	希望小売 価格(円) Suggested retail price (¥)		
ABPF06S(○)(W/WL(○))	適用カッタ Cutter Body	581-140	0.5	1,970	104-T6	A	1,800	P-37	1,010
ABPF08S(○)(L/W/WL/WL(○)/WLT(○))		581-141	1.1	1,490	104-T8	A	1,800		
ABPF10S(○)(L/W/WL/WL(○)/WLT(○)) ABPFM10(-M6H)		581-142	2.2	1,490	104-T10	A	1,920		
ABPF12S(○)(L/W/WL/WL(○)/WLT(○)) ABPFM12(-M6H)		581-143	4.9	1,490	105-T20	B	2,120		
ABPF16S(○)(L/W(○)/WL(○)/WE/WE(○)/WLT(○))		581-144	4.9	1,490					
ABPFU16W220 ABPFM16(-M8H)		581-145	6.9	1,490	101-T25S	B	1,440		
ABPF20S(○)(L/W(○)/WL(○)/WE/WE(○)/WLT(○))									
ABPF20MT2 ABPFU20W270 ABPFM20(-M10H)									
ABPF25S(○)(L/W(○)/WL(○)/WE/WE(○)/WLT(○))		581-146	9.8	1,710	105-T30A	B	2,120		
ABPF25MT3 ABPFU25W300 ABPFM25(-M12H)		581-147	9.8	1,710					
ABPF30S(○)(L/W(○)/WL(○)/WE/WE(○)/WLT(○))									
ABPF30MT4 ABPFU30W300 ABPFM30(-M16H)									
ABPF32S(○)(L/W(○)/WL(○)/WE(○))		581-147	9.8	1,710					
ABPF32MT4 ABPFM32									

【注意】クランプねじは消耗品です。使用環境により交換寿命は変化しますので早めの交換をお願い致します。

【Note】The clamp screw is a consumable part. Since replacement life depends on the use environment, it is recommended that it be replaced at an early stage.

モジュラーミル用アーバ

Modular Mill Arbor

BT30

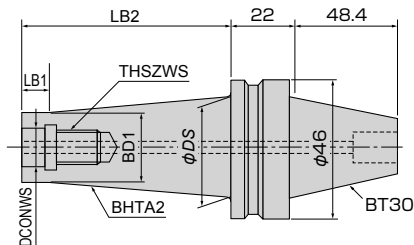

※首部分は、ユーザー様にて追加加工可能です。
 ※For neck section, additional machining to user specifications is possible.

商品コード Item code	在庫 Stock	寸法 Size (mm)						
		DCONWS	THSZWS	BD1	φDS	LB2	LB1	BHTA2
BT30-6.5-30-9.7						30	5	17°
BT30-6.5-55-9.7		6.5	M6	9.7	25	55	10	9.6°
BT30-6.5-85-9.7						80	10	6.2°
BT30-8.5-25-15						25	5	20.6°
BT30-8.5-50-15		8.5	M8	15	30	50	10	10.6°
BT30-8.5-75-15						75	10	6.6°
BT30-10.5-20-18						20	5	29.5°
BT30-10.5-45-18		10.5	M10	18	35	45	10	13.7°
BT30-10.5-70-18						70	10	8.1°
BT30-12.5-15-21						15	5	32.3°
BT30-12.5-40-21		12.5	M12	21	40	40	10	17.6°
BT30-12.5-65-21						65	10	9.8°
BT30-12.5-85-21						85	10	7.2°
BT30-17-10-28						10	5	31°
BT30-17-35-28		17	M16	28	40	35	10	13.5°
BT30-17-60-28						60	10	6.8°

【注意】加工状況により振動が懸念される場合は、1.切り込み深さ(ap)を低減する 2.一刃当りの送り(fz)を低減する方法で調整下さい。

【Note】If vibrations are a concern due to the processing conditions, adjust conditions by 1.reducing cutting depth (ap) or 2.reducing per-flute feed rate (fz).

BT40

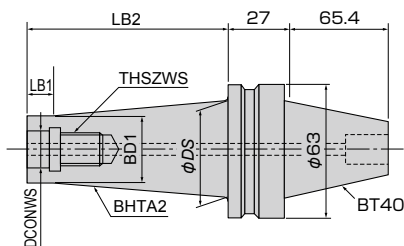

※首部分は、ユーザー様にて追加加工可能です。
 ※For neck section, additional machining to user specifications is possible.

商品コード Item code	在庫 Stock	寸法 Size (mm)						
		DCONWS	THSZWS	BD1	φDS	LB2	LB1	BHTA2
BT40-6.5-30-9.7						30	5	17°
BT40-6.5-55-9.7		6.5	M6	9.7	25	55	10	9.6°
BT40-6.5-80-9.7						80	10	6.2°
BT40-6.5-130-9.7						130	10	3.6°
BT40-8.5-25-15						25	5	20.6°
BT40-8.5-50-15		8.5	M8	15	30	50	10	10.6°
BT40-8.5-75-15						75	10	6.6°
BT40-8.5-125-15						125	10	3.7°
BT40-10.5-20-18						20	5	29.5°
BT40-10.5-45-18		10.5	M10	18	35	45	10	13.7°
BT40-10.5-70-18						70	10	8.1°
BT40-10.5-120-18						120	10	4.4°
BT40-12.5-15-21						15	5	32.3°
BT40-12.5-40-21		12.5	M12	21	40	40	10	17.6°
BT40-12.5-65-21						65	10	9.8°
BT40-12.5-115-21						115	10	5.2°
BT40-17-10-28						10	5	45°
BT40-17-35-28		17	M16	28	48	35	10	21.8°
BT40-17-60-28						60	10	11.3°
BT40-17-110-28						110	10	5.7°

【注意】加工状況により振動が懸念される場合は、1.切り込み深さ(ap)を低減する 2.一刃当りの送り(fz)を低減する方法で調整ください。

【Note】If vibrations are a concern due to the processing conditions, adjust conditions by 1.reducing cutting depth (ap) or 2.reducing per-flute feed rate (fz).

HSK

(モジュラーミルタイプ)
 HSK Arbor
 Modular Mill Type

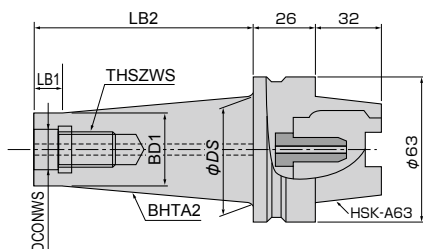

商品コード Item code	在庫 Stock	寸法 Size (mm)						希望小売 価格(円) Suggested retail price (¥)	
		DCONWS	THSZWS	BD1	φDS	LB2	LB1		BHTA2
HSK-A63-10.5-30-18	●				20.8	30	—	3°	94,560
HSK-A63-10.5-70-18	●	10.5	M10	18	25	70	10	3°	97,130
HSK-A63-10.5-70-18S					48	70	10	12°	—
HSK-A63-10.5-120-18	●				30.2	120	10	3°	101,350
HSK-A63-12.5-35-21	●				24.3	35	—	3°	95,490
HSK-A63-12.5-65-21	●	12.5	M12	21	27.5	65	10	3°	96,660
HSK-A63-12.5-65-21S					48	65	10	12°	—
HSK-A63-12.5-115-21	●				32.7	115	10	3°	101,710
HSK-A63-17-40-28	●				31.8	40	—	3°	95,490
HSK-A63-17-60-28	●	17	M16	28	33.9	60	10	3°	96,660
HSK-A63-17-60-28S					48	60	10	9.5°	—
HSK-A63-17-110-28	●				39.2	110	10	3°	101,120

●印：標準在庫品です。●：Stocked items. 無印：受注生産品です。No mark：Manufactured upon request only.

レッドスクリューアーバ

Red screw arbor

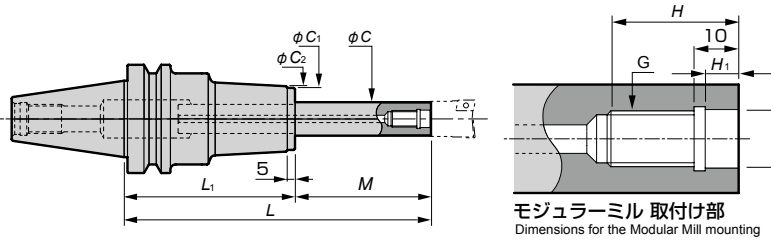

■注意事項 Caution

- 一部取付けできない交換式工具があります。取付け可能な「交換式工具取付け部」で寸法を確認いただくか、弊社までお問い合わせください。
- ※の商品は、条件を工具の推奨条件の半分程度に落とさずにご使用ください。機械とシャンクとの結合力に比べ、切削抵抗が大きくなり、ホルダシャンク部でフレッチング現象またはホルダの抜けが発生します。
- Some of the indexable end mills cannot be attached to the RED screw arbor. Please check your indexable end mills for conformance to the dimensions, or please contact MOLDINO Tool Engineering, Ltd.
- Because cutting resistance is greater than the tool holder connection force associated with the machine spindle, please reduce the recommended cutting conditions by 50% for the RED screw arbors marked with ※. Otherwise, the tool holder shank may experience fretting corrosion or fall out of the machine spindle.

商品コード Item code	在庫 Stock	寸法 Size(mm)										重量 (kg) Weight	剛性値 (μm) Rigidity value δ↓
		G	φD	H	H ₁	φC	L	M	L ₁	φC ₁	φC ₂		
BT40-RSG8-105-M25							105	80				1.4	0.6
BT40-RSG8-135-M25							135	25	110			1.8	0.7
BT40-RSG8-165-M25							165	140				2.1	0.8
BT40-RSG8-130-M50							130	80				1.4	1.5
BT40-RSG8-160-M50							160	50	110			1.8	1.7
BT40-RSG8-190-M50							190	140				2.1	1.8
BT40-RSG8-155-M75							155	80				1.5	3.1
BT40-RSG8-185-M75		M8	8.5	18	6.5	15	185	75	110	30	32	1.9	3.4
BT40-RSG8-215-M75							215	140				2.2	3.5
BT40-RSG8-170-M90							170	80				1.5	4.5
BT40-RSG8-200-M90							200	90	110			1.9	4.8
BT40-RSG8-230-M90							230	140				2.2	4.9
BT40-RSG8-185-M105							185	80				1.6	6.2
BT40-RSG8-215-M105							215	105	110			2.0	6.7
BT40-RSG8-245-M105							245	140				2.3	6.8
BT40-RSG10-125-M25							125	100				1.8	0.4
BT40-RSG10-155-M25							155	25	130			2.2	0.5
BT40-RSG10-185-M25							185	160				2.4	0.7
BT40-RSG10-150-M50							150	100				1.9	0.8
BT40-RSG10-180-M50							180	50	130			2.3	1.0
BT40-RSG10-210-M50							210	160				2.5	1.2
BT40-RSG10-175-M75							175	100				2.0	1.6
BT40-RSG10-205-M75		M10	10.5	22	6.5	19	205	75	130	36	38	2.4	1.8
BT40-RSG10-235-M75							235	160				2.6	2.0
BT40-RSG10-200-M100							200	100				2.0	2.7
BT40-RSG10-230-M100							230	100	130			2.4	3.0
BT40-RSG10-260-M100							260	160				2.6	3.3
BT40-RSG10-220-M120							220	100				2.1	4.0
BT40-RSG10-250-M120							250	120	130			2.5	4.3
BT40-RSG10-280-M120							280	160				2.7	4.6
BT40-RSG12-125-M25							125	100				2.0	0.3
BT40-RSG12-155-M25							155	25	130			2.4	0.4
BT40-RSG12-185-M25							185	160				2.7	0.5
BT40-RSG12-150-M50							150	100				2.1	0.5
BT40-RSG12-180-M50							180	50	130			2.5	0.7
BT40-RSG12-210-M50							210	160				2.8	0.9
BT40-RSG12-175-M75		M12	12.5	22	6	24	175	100		43	45	2.3	0.9
BT40-RSG12-205-M75							205	75	130			2.7	1.1
BT40-RSG12-235-M75							235	160				3.0	1.3
BT40-RSG12-200-M100							200	100				2.4	1.4
BT40-RSG12-230-M100							230	100	130			2.8	1.6
BT40-RSG12-260-M100							260	160				3.1	1.9
BT40-RSG12-225-M125							225	100				2.6	2.1
BT40-RSG12-255-M125			M12	12.5	22	6	255	125	130	43	45	3.0	2.4
BT40-RSG12-285-M125							285	160				3.3	2.8
BT40-RSG16-125-M25							125	25				2.6	0.2
BT40-RSG16-150-M50							150	50				2.8	0.3
BT40-RSG16-175-M75		M16	17	25	6	29	175	75	100	52	54	3.0	0.5
BT40-RSG16-200-M100							200	100				3.2	0.8
BT40-RSG16-225-M125 ※							225	125				3.4	1.2
BT50-RSG8-120-M25							120	95				4.0	0.6
BT50-RSG8-150-M25							150	25	125			4.3	0.7
BT50-RSG8-180-M25							180	155				4.8	0.7
BT50-RSG8-145-M50							145	95				4.0	1.5
BT50-RSG8-175-M50							175	50	125			4.3	1.7
BT50-RSG8-205-M50							205	155				4.8	1.7
BT50-RSG8-170-M75							170	95				4.1	3.1
BT50-RSG8-200-M75		M8	8.5	18	6.5	15	200	75	125	30	32	4.4	3.4
BT50-RSG8-230-M75							230	155				4.9	3.4
BT50-RSG8-185-M90							185	95				4.9	4.4
BT50-RSG8-215-M90							215	90	125			4.4	4.8
BT50-RSG8-245-M90							245	155				4.9	4.8
BT50-RSG8-200-M105							200	95				4.2	6.2
BT50-RSG8-230-M105							230	105	125			4.5	6.6
BT50-RSG8-260-M105							260	155				5.0	6.6
BT50-RSG10-140-M25							140	115				4.3	0.4
BT50-RSG10-170-M25							170	25	145			4.6	0.5
BT50-RSG10-200-M25							200	175				5.6	0.5
BT50-RSG10-165-M50							165	115				4.4	0.8
BT50-RSG10-195-M50							195	50	145			4.7	0.9
BT50-RSG10-225-M50							225	175				5.7	1.0
BT50-RSG10-190-M75							190	115				4.5	1.6
BT50-RSG10-220-M75							220	75	145			4.8	1.7
BT50-RSG10-250-M75		M10	10.5	22	6.5	19	250	175		36	38	5.8	1.8
BT50-RSG10-215-M100							215	115				4.5	2.7
BT50-RSG10-245-M100							245	100	145			4.8	2.9
BT50-RSG10-275-M100							275	175				5.8	2.9
BT50-RSG10-235-M120							235	115				4.6	3.9
BT50-RSG10-265-M120							265	120	145			4.9	4.2
BT50-RSG10-295-M120							295	175				5.9	4.2
BT50-RSG10-255-M140							255	115				4.7	5.5
BT50-RSG10-285-M140							285	140	145			5.0	5.8
BT50-RSG10-315-M140							315	175				6.0	5.8
BT50-RSG12-140-M25		M12	12.5	22	6	24	140	25	115	43	45	4.6	0.2

無印：受注生産品です。No mark：Manufactured upon request only. 納期は受注後 10 日程度になります。Delivery time is about ten days after an order received.

ラインナップ

Line Up

商品コード Item code	在庫 Stock	寸法 Size(mm)										重量 (kg) Weight	剛性値 (μ m) Rigidity value δ ↓	商品コード Item code	在庫 Stock	寸法 Size(mm)										重量 (kg) Weight	剛性値 (μ m) Rigidity value δ ↓	
		G	ϕ D	H	H ₁	ϕ C	L	M	L ₁	ϕ C ₁	ϕ C ₂					G	ϕ D	H	H ₁	ϕ C	L	M	L ₁	ϕ C ₁	ϕ C ₂			
BT50-RSG12-170-M25							170		145				5.0	0.3	A63-RSG8-160-M50							160	50	110			1.4	1.7
BT50-RSG12-200-M25							200	25	175				5.8	0.4	A63-RSG8-190-M50							190	140				1.9	1.7
BT50-RSG12-165-M50							165		115				4.7	0.5	A63-RSG8-155-M75							155	80				1.4	3.1
BT50-RSG12-195-M50							195	50	145				5.1	0.6	A63-RSG8-185-M75							185	75	110			1.5	3.4
BT50-RSG12-225-M50							225		175				5.9	0.6	A63-RSG8-215-M75							215	140				2.0	3.4
BT50-RSG12-190-M75							190		115				4.9	0.8	A63-RSG8-170-M90	M8	8.5	18	6.5	15		170		80	30	32	2.0	4.4
BT50-RSG12-220-M75							220	75	145				5.3	1.0	A63-RSG8-200-M90							200	90	110			1.5	4.8
BT50-RSG12-250-M75							250		175				6.1	1.0	A63-RSG8-230-M90							230	140				2.0	4.9
BT50-RSG12-215-M100							215		115				5.0	1.3	A63-RSG8-185-M105							185	80				1.5	6.2
BT50-RSG12-245-M100		M12	12.5	22	6	24	245	100	145		43	45	5.4	1.5	A63-RSG8-215-M105							215	105	110			1.6	6.6
BT50-RSG12-275-M100							275		175				6.2	1.6	A63-RSG8-245-M105							245	140				2.1	6.7
BT50-RSG12-240-M125							240		115				5.2	2.1	A63-RSG10-125-M25							125	100				1.6	0.4
BT50-RSG12-270-M125							270	125	145				5.6	2.3	A63-RSG10-155-M25							155	25	130			1.9	0.5
BT50-RSG12-300-M125							300		175				6.4	2.4	A63-RSG10-185-M25							185	160				2.3	0.6
BT50-RSG12-265-M150							265		115				5.3	3.0	A63-RSG10-150-M50							150	100				1.7	0.8
BT50-RSG12-295-M150							295	150	145				5.7	3.3	A63-RSG10-180-M50							180	50	130			2.0	1.0
BT50-RSG12-325-M150							325		175				6.5	3.4	A63-RSG10-210-M50							210	160				2.4	1.2
BT50-RSG12-290-M175							290		115				5.5	4.2	A63-RSG10-175-M75							175	100				1.8	1.6
BT50-RSG12-320-M175							320	175	145				5.9	4.6	A63-RSG10-205-M75							205	75	130			2.1	1.8
BT50-RSG12-350-M175							350		175				6.7	4.6	A63-RSG10-235-M75							235	160				2.5	2.0
BT50-RSG16-140-M25							140		115				4.8	0.2	A63-RSG10-200-M100	M10	10.5	22	6.5	19		200		100	36	38	1.8	2.7
BT50-RSG16-170-M25							170	25	145				5.4	0.2	A63-RSG10-230-M100							230	100	130			2.1	2.9
BT50-RSG16-200-M25							200		175				6.6	0.2	A63-RSG10-260-M100							260	160				2.5	3.2
BT50-RSG16-165-M50							165		115				5.0	0.3	A63-RSG10-220-M120							220	100				1.9	4.0
BT50-RSG16-195-M50							195	50	145				5.6	0.4	A63-RSG10-250-M120							250	120	130			2.2	4.2
BT50-RSG16-225-M50							225		175				6.8	0.4	A63-RSG10-280-M120							280	160				2.6	4.5
BT50-RSG16-190-M75							190		115				5.3	0.5	A63-RSG10-240-M140							240	100				2.0	5.6
BT50-RSG16-220-M75							220	75	145				5.9	0.6	A63-RSG10-270-M140							270	140	130			2.3	5.9
BT50-RSG16-250-M75							250		175				7.0	0.6	A63-RSG10-300-M140							300	160				2.7	6.2
BT50-RSG16-215-M100							215		115				5.5	0.7	A63-RSG12-125-M25							125	100				1.9	0.3
BT50-RSG16-245-M100							245	100	145				6.1	0.9	A63-RSG12-155-M25							155	25	130			2.3	0.4
BT50-RSG16-275-M100							275		175				7.2	0.9	A63-RSG12-185-M25							185	160				2.7	0.5
BT50-RSG16-240-M125							240		115				5.7	1.1	A63-RSG12-150-M50							150	100				2.0	0.5
BT50-RSG16-270-M125		M16	17	25	6	29	270	125	145		52	54	6.3	1.3	A63-RSG12-180-M50							180	50	130			2.4	0.6
BT50-RSG16-300-M125							300		175				7.4	1.3	A63-RSG12-210-M50							210	160				2.8	0.8
BT50-RSG16-265-M150							265		115				5.9	1.6	A63-RSG12-175-M75							175	100				2.2	0.9
BT50-RSG16-295-M150							295	150	145				6.5	1.8	A63-RSG12-205-M75							205	75	130			2.6	1.0
BT50-RSG16-325-M150							325		175				7.7	1.8	A63-RSG12-235-M75							235	160				3.0	1.3
BT50-RSG16-290-M175							290		115				6.1	2.2	A63-RSG12-200-M100	M12	12.5	22	6	24		200		100	43	45	2.3	1.4
BT50-RSG16-320-M175							320	175	145				6.7	2.4	A63-RSG12-230-M100							230	100	130			2.7	1.6
BT50-RSG16-350-M175							350		175				7.9	2.5	A63-RSG12-260-M100							260	160				3.1	1.9
BT50-RSG16-315-M200							315		115				6.3	3.0	A63-RSG12-225-M125							225	100				2.5	2.1
BT50-RSG16-345-M200							345	200	145				6.9	3.2	A63-RSG12-255-M125							255	125	130			2.9	2.4
BT50-RSG16-375-M200							375		175				8.1	3.3	A63-RSG12-285-M125							285	160				3.3	2.7
BT50-RSG16-340-M225							340		115				6.5	3.9	A63-RSG12-250-M150							250	100				2.6	3.1
BT50-RSG16-370-M225							370	225	145				7.1	4.1	A63-RSG12-280-M150							280	150	130			3.0	3.4
BT50-RSG16-400-M225							400		175				8.3	4.2	A63-RSG12-310-M150							310	160				3.4	3.8
A63-RSG8-105-M25							105		80				1.3	0.6	A63-RSG16-140-M25							140	25				2.8	0.2
A63-RSG8-135-M25		M8	8.5	18	6.5	15	135	25	110		30	32	1.4	0.7	A63-RSG16-165-M50	M16	17	25	6	29		165	50	115	52	54	3.2	0.4
A63-RSG8-165-M25							165		140				1.9	0.8	A63-RSG16-190-M75							190	75				3.6	0.6
A63-RSG8-130-M50							130	50	80				1.3	1.5	A63-RSG16-215-M100							215	100				2.8	0.9

無印：受注生産品です。No mark：Manufactured upon request only。納期は受注後 10 日程度になります。Delivery time is about ten days after an order received.

商品コード Item code	在庫 Stock	寸法 Size(mm)										重量 (kg) Weight	剛性値 (μm) Rigidity value δ	
		G	ϕD	H	H ₁	ϕC	L	M	L ₁	ϕC_1	ϕC_2			
AG6							240	125					2.8	1.3
		M16	17	25	6	29	265	150	115	52	54		3.2	1.9
							290	175					3.6	2.5
A100							120		95				2.6	0.6
							150	25	125				2.9	0.8
							180		155				3.4	0.8
							145		95				2.6	1.5
							175	50	125				2.9	1.7
							205		155				3.4	1.7
							170		95				2.7	3.1
		M8	8.5	18	6.5	15	200	75	125	30	32		3.0	3.4
							230		155				3.5	3.4
							185		95				2.7	4.5
							215	90	125				3.0	4.9
							245		155				3.5	4.8
							200		95				2.8	6.3
							230	105	125				3.1	6.7
							260		155				3.6	6.6
							140		115				3.1	0.4
							170	25	145				3.5	0.5
							200		175				4.4	0.5
							165		115				3.2	0.8
							195	50	145				3.6	1.0
						225		175				4.5	1.0	
						190		115				3.3	1.6	
						220	75	145				3.7	1.8	
						250		175				4.6	1.8	
	M10	10.5	22	6.5	19	215		115	36	38		3.3	2.7	
						245	100	145				3.7	2.9	
						275		175				4.6	2.9	
						235		115				3.4	4.0	
						265	120	145				3.8	4.2	
						295		175				4.7	4.2	
						255		115				3.5	5.6	
						285	140	145				3.9	5.8	
						315		175				4.8	5.8	
						140		115				3.4	0.3	
						170	25	145				3.7	0.4	
						200		175				4.7	0.4	
	M12	12.5	22	6	24	165		115	43	45		3.5	0.5	
						195	50	145				3.8	0.6	
						225		175				4.8	0.6	

商品コード Item code	在庫 Stock	寸法 Size(mm)										重量 (kg) Weight	剛性値 (μm) Rigidity value δ	
		G	ϕD	H	H ₁	ϕC	L	M	L ₁	ϕC_1	ϕC_2			
A100-RSG12-190-M75							190		115				3.7	0.8
A100-RSG12-220-M75							220	75	145				4.0	1.0
A100-RSG12-250-M75							250		175				5.0	1.0
A100-RSG12-215-M100							215		115				3.8	1.4
A100-RSG12-245-M100							245	100	145				4.1	1.6
A100-RSG12-275-M100							275		175				5.1	1.6
A100-RSG12-240-M125							240		115				4.0	2.1
A100-RSG12-270-M125	M12	12.5	22	6	24	270	125	145	43	45		4.3	2.4	
A100-RSG12-300-M125						300		175				5.3	2.4	
A100-RSG12-265-M150						265		115				4.1	3.0	
A100-RSG12-295-M150						295	150	145				4.4	3.4	
A100-RSG12-325-M150						325		175				5.4	3.4	
A100-RSG12-290-M175						290		115				4.3	4.3	
A100-RSG12-320-M175						320	175	145				4.6	4.6	
A100-RSG12-350-M175						350		175				5.6	4.6	
A100-RSG16-140-M25						140		115				4.0	0.2	
A100-RSG16-170-M25						170	25	145				4.5	0.2	
A100-RSG16-200-M25						200		175				5.7	0.2	
A100-RSG16-165-M50						165		115				4.2	0.3	
A100-RSG16-195-M50						195	50	145				4.7	0.4	
A100-RSG16-225-M50						225		175				5.9	0.4	
A100-RSG16-190-M75						190		115				4.5	0.5	
A100-RSG16-220-M75						220	75	145				5.0	0.6	
A100-RSG16-250-M75						250		175				6.1	0.6	
A100-RSG16-215-M100						215		115				4.7	0.8	
A100-RSG16-245-M100						245	100	145				5.2	0.9	
A100-RSG16-275-M100						275		175				6.3	0.9	
A100-RSG16-240-M125						240		115				4.9	1.1	
A100-RSG16-270-M125	M16	17	25	6	29	270	125	145	52	54		5.4	1.3	
A100-RSG16-300-M125						300		175				6.5	1.3	
A100-RSG16-265-M150						265		115				5.1	1.6	
A100-RSG16-295-M150						295	150	145				5.6	1.8	
A100-RSG16-325-M150						325		175				6.7	1.8	
A100-RSG16-290-M175						290		115				5.3	2.2	
A100-RSG16-320-M175						320	175	145				5.8	2.4	
A100-RSG16-350-M175						350		175				7.0	2.5	
A100-RSG16-315-M200						315		115				5.5	3.0	
A100-RSG16-345-M200						345	200	145				6.0	3.2	
A100-RSG16-375-M200						375		175				7.2	3.3	
A100-RSG16-340-M225						340		115				5.7	3.9	
A100-RSG16-370-M225						370	225	145				6.3	4.2	
A100-RSG16-400-M225						400		175				7.4	4.2	

- 標準付属品 ●クーラントダクト(HSK-A)
- 注意事項 ●モジュラーミルは付属しません。
- プルスタッドは付属していません。
- ご使用になるモジュラーミルが取付可能か「モジュラーミル取付部」で寸法をご確認ください。

- Standard accessories ●Coolant duct(HSK)
- Caution ●The Modular Mill is not a standard accessory.
- Pull stud is not a standard accessory.
- Please check your Modular Mills for conformance to the dimensions.

δ 剛性値について About the rigidity value

モジュラーミル先端に1kgf (9.8N)の曲げ荷重をかけた時のホルダと工具全体がたわむ量を表しています。数値が小さい程、剛性があり精度の高い加工が可能です。

A rigidity value represents the amount of deflection for the entire holder and tool when a bending load of 1 kgf (9.8 N) is applied to the tip of the tool. The smaller the numerical value is, the higher the rigidity and the more accurate the machining.

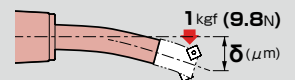

標準切削条件表

Recommended Cutting Conditions

※赤字は第1推奨材種です。Red indicates primary recommended insert grades.

被削材 Work material	推奨材種 Recommended inserts grade		切削条件 Cutting conditions	φ6			φ8			φ10			φ12		
	強ねじれ刃形 High helix edge shape	一般刃形 Standard		中仕上げ Semi Finishing		仕上げ Finishing	中仕上げ Semi Finishing		仕上げ Finishing	中仕上げ Semi Finishing		仕上げ Finishing	中仕上げ Semi Finishing		仕上げ Finishing
				汎用 General purpose	高速加工 High-speed processing		汎用 General purpose	高速加工 High-speed processing		汎用 General purpose	高速加工 High-speed processing		汎用 General purpose	高速加工 High-speed processing	
炭素鋼 合金鋼 (30HRC以下) Carbon steels Alloy steels (30HRC or less)	※ PN08M PN15M TH303 ATH80D ATH10E	ACS05E PCA12M PCA08M	n (min ⁻¹)	8,490	16,450	16,450	6,370	12,340	12,340	5,100	9,240	11,150	4,250	7,170	10,080
			v_c (m/min)	160	310	310	160	310	310	160	290	350	160	270	380
			vf (mm/min)	1,700	4,930	3,290	2,550	9,870	4,940	2,040	7,390	4,460	1,700	5,740	4,030
			fz (mm/t)	0.1	0.15	0.1	0.2	0.4	0.2	0.2	0.4	0.2	0.2	0.4	0.2
			a_p (mm)	0.1	0.05	0.05	0.2	0.1	0.1	0.25	0.15	0.1	0.3	0.2	0.1
			a_e (mm)	0.6	0.6	0.2	0.8	0.8	0.25	1	0.8	0.25	1.2	0.9	0.3
炭素鋼 合金鋼 (30~45HRC) Carbon steels Alloy steels	PN08M PN15M TH303 ATH80D	ACS05E PCA12M PCA08M	n (min ⁻¹)	6,370	14,320	14,320	4,780	10,750	10,750	3,820	7,640	9,550	3,180	6,100	8,760
			v_c (m/min)	120	270	270	120	270	270	120	240	300	120	230	330
			vf (mm/min)	1,270	4,300	2,860	1,910	8,600	4,300	1,530	6,110	3,820	1,270	4,880	3,500
			fz (mm/t)	0.1	0.15	0.1	0.2	0.4	0.2	0.2	0.4	0.2	0.2	0.4	0.2
			a_p (mm)	0.1	0.05	0.05	0.2	0.1	0.1	0.25	0.15	0.1	0.3	0.2	0.1
			a_e (mm)	0.6	0.6	0.2	0.8	0.8	0.25	1	0.8	0.25	1.2	0.9	0.3
鋳鉄 Cast irons	ATH10E TH303 ATH80D PTH08M PCA12M PCA08M PN08M PN15M	ACS05E ATH80D PTH08M PCA12M PCA08M	n (min ⁻¹)	8,490	16,450	16,450	6,370	12,340	12,340	5,090	9,240	11,150	4,240	7,170	10,080
			v_c (m/min)	160	310	310	160	310	310	160	290	350	160	270	380
			vf (mm/min)	1,700	6,580	3,290	3,820	14,810	4,940	3,050	11,090	6,690	2,550	8,600	6,050
			fz (mm/t)	0.1	0.2	0.1	0.3	0.6	0.2	0.3	0.6	0.3	0.3	0.6	0.3
			a_p (mm)	0.1	0.05	0.05	0.2	0.1	0.1	0.25	0.15	0.1	0.3	0.2	0.1
			a_e (mm)	0.6	0.6	0.2	0.8	0.8	0.25	1	0.8	0.25	1.2	0.9	0.3
グラファイト Graphite	HD7010 ATH10E	HD7010	n (min ⁻¹)	15,920	21,220	21,220	11,940	15,920	15,920	9,550	12,740	12,740	7,960	10,620	10,620
			v_c (m/min)	300	400	400	300	400	400	300	400	400	300	400	400
			vf (mm/min)	3,180	6,370	4,240	4,780	9,550	6,370	3,820	7,640	5,100	3,190	6,370	4,240
			fz (mm/t)	0.1	0.15	0.1	0.2	0.3	0.2	0.2	0.3	0.2	0.2	0.3	0.2
			a_p (mm)	0.3	0.15	0.15	0.4	0.2	0.2	0.5	0.3	0.2	0.6	0.4	0.2
			a_e (mm)	0.6	0.6	0.2	0.8	0.8	0.25	1.0	0.8	0.25	1.2	0.9	0.3
アルミニウム 合金鋳物 Cast aluminum alloys AC4A, ADC12等	HD7010 PN08M	HD7010	n (min ⁻¹)	15,920	26,530	26,530	11,940	19,900	19,900	9,550	15,920	15,920	7,960	13,270	13,270
			v_c (m/min)	300	500	500	300	500	500	300	500	500	300	500	500
			vf (mm/min)	3,180	10,610	5,310	4,780	15,920	7,960	3,820	12,740	6,370	3,190	10,620	5,310
			fz (mm/t)	0.1	0.2	0.1	0.2	0.4	0.2	0.2	0.4	0.2	0.2	0.4	0.2
			a_p (mm)	0.3	0.15	0.15	0.4	0.2	0.2	0.5	0.3	0.2	0.6	0.4	0.2
			a_e (mm)	0.6	0.6	0.2	0.8	0.8	0.25	1.0	0.8	0.25	1.2	0.9	0.3
焼入れ鋼 45~55HRC Hardened steels	TH303 ATH80D PN15M PCA12M PCA08M ACS05E	ATH80D PTH08M PCA12M PCA08M ACS05E	n (min ⁻¹)	5,310	12,200	12,200	3,980	9,160	9,160	3,180	6,690	8,280	2,650	5,310	7,700
			v_c (m/min)	100	230	230	100	230	230	100	210	260	100	200	290
			vf (mm/min)	850	2,440	2,440	800	3,660	3,660	640	2,680	3,310	530	2,120	3,080
			fz (mm/t)	0.08	0.1	0.1	0.1	0.2	0.2	0.1	0.2	0.2	0.1	0.2	0.2
			a_p (mm)	0.1	0.05	0.05	0.2	0.1	0.1	0.25	0.15	0.1	0.3	0.2	0.1
			a_e (mm)	0.6	0.6	0.2	0.8	0.8	0.25	1	0.8	0.25	1.2	0.9	0.3
焼入れ鋼 55~62HRC Hardened steels	TH303 ATH80D	ATH80D (PTH08M)	n (min ⁻¹)	4,240	9,550	9,550	3,180	7,170	7,170	2,550	5,410	6,370	2,120	4,250	6,100
			v_c (m/min)	80	180	180	80	180	180	80	170	200	80	160	230
			vf (mm/min)	680	1,910	1,910	640	2,870	2,870	510	2,160	2,550	420	1,700	2,440
			fz (mm/t)	0.08	0.1	0.1	0.1	0.2	0.2	0.1	0.2	0.2	0.1	0.2	0.2
			a_p (mm)	0.1	0.05	0.05	0.2	0.1	0.1	0.25	0.15	0.1	0.3	0.2	0.1
			a_e (mm)	0.6	0.6	0.2	0.8	0.8	0.25	1	0.8	0.25	1.2	0.9	0.3
最大 fz Maximum fz (mm/t)				< 0.2			< 0.8			< 0.8			< 0.8		
最大 a_p Maximum a_p (mm)				< 3.0			< 4.0			< 5.0			< 6.0		

- [注意]** ①被削材、加工形状に合わせて、適切なクーラントを使用してください。
 ②この切削条件表は切削条件の目安を示すものです。実際の加工では加工形状、目的、使用機械等により条件を調整してください。
 ③この工具をご使用の際は、破損する危険性がありますので、必ずカバー・保護めがね・安全靴等をご使用してください。
 ④超硬シャンクホルダには手を加えないでください。また、突き出し長3DC以上の仕上げ加工は、切込み量 a_p を工具径DC12mm以下は $a_p=0.2$ mm以下、工具径DC16mm以上は $a_p=0.3$ mm以下を目安にご使用ください。

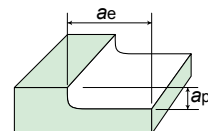

- [Note]** ①Use the appropriate coolant for the work material and machining shape.
 ②These conditions are for general guidance; in actual machining conditions adjust the parameters according to your actual machine and work-piece conditions.
 ③Be sure to practice safety instructions and precautions such as wearing glasses and safety shoes, and placing safety covers when you use this tool. Because this tool can be broken during machining so failure to follow these instructions may cause personal injury.
 ④Never attempt to modify the carbide shank holder. In case of finish cut with overhang=3DC or more, please set cutting depth a_p as below.
 When DC=12mm or less, $a_p=0.2$ mm or less. When DC=16mm or more, $a_p=0.3$ mm or less.

φ16			φ20			φ25			φ30			φ32			被削材 Work material
中仕上げ Semi Finishing		仕上げ Finishing	中仕上げ Semi Finishing		仕上げ Finishing	中仕上げ Semi Finishing		仕上げ Finishing	中仕上げ Semi Finishing		仕上げ Finishing	中仕上げ Semi Finishing		仕上げ Finishing	
汎用 General purpose	高速加工 High-speed processing		汎用 General purpose	高速加工 High-speed processing		汎用 General purpose	高速加工 High-speed processing		汎用 General purpose	高速加工 High-speed processing		汎用 General purpose	高速加工 High-speed processing		
3,180	4,180	9,950	2,550	3,340	9,080	2,040	2,680	8,030	1,700	2,230	7,640	1,590	2,090	7,170	炭素鋼 合金鋼 (30HRC以下) Carbon steels Alloy steels (30HRC or less)
160	210	500	160	210	570	160	210	630	160	210	720	160	210	720	
1,590	4,180	5,970	1,280	3,340	7,260	1,020	2,680	8,030	850	2,230	9,170	800	2,090	8,600	
0.25	0.5	0.3	0.25	0.5	0.4	0.25	0.5	0.5	0.25	0.5	0.6	0.25	0.5	0.6	
0.8	0.6	0.1	1	0.7	0.1	1.25	0.9	0.1	1.6	1.1	0.1	1.6	1.1	0.1	
1.6	1.1	0.35	2	1.5	0.4	2.5	1.8	0.5	3.2	2.4	0.5	3.2	2.4	0.5	
2,390	2,990	7,560	1,910	2,550	6,690	1,530	2,040	5,990	1,270	1,700	5,730	1,190	1,590	5,370	炭素鋼 合金鋼 (30~45HRC) Carbon steels Alloy steels
120	150	380	120	160	420	120	160	470	120	160	540	120	160	540	
1,200	2,990	4,540	960	2,550	5,350	770	2,040	5,990	640	1,700	6,880	600	1,590	6,440	
0.25	0.5	0.3	0.25	0.5	0.4	0.25	0.5	0.5	0.25	0.5	0.6	0.25	0.5	0.6	
0.8	0.6	0.1	1	0.7	0.1	1.25	0.9	0.1	1.6	1.1	0.1	1.6	1.1	0.1	
1.6	1.1	0.3	2	1.5	0.4	2.5	1.8	0.5	3.2	2.4	0.6	3.2	2.4	0.6	
3,180	4,180	9,950	2,550	3,340	9,080	2,040	2,680	8,030	1,700	2,230	7,640	1,590	2,090	7,170	鑄鉄 Cast irons
160	210	500	160	210	570	160	210	630	160	210	720	160	210	720	
2,230	5,850	5,970	1,790	4,680	7,260	1,430	3,750	8,030	1,190	3,120	9,170	1,110	2,930	8,600	
0.35	0.7	0.3	0.35	0.7	0.4	0.35	0.7	0.5	0.35	0.7	0.6	0.35	0.7	0.6	
0.8	0.6	0.1	1	0.7	0.1	1.25	0.9	0.1	1.6	1.1	0.1	1.6	1.1	0.1	
1.6	1.1	0.3	2	1.5	0.4	2.5	1.8	0.5	3.2	2.4	0.6	3.2	2.4	0.6	
5,970	7,960	7,960	4,780	6,370	6,370	3,820	5,090	5,090	3,180	4,240	4,240				グラファイト Graphite
300	400	400	300	400	400	300	400	400	300	400	400				
2,990	4,780	3,980	2,390	3,820	3,190	1,910	5,090	5,090	1,590	4,240	5,090				
0.25	0.3	0.25	0.25	0.3	0.25	0.25	0.5	0.5	0.25	0.5	0.6				
0.8	0.6	0.1	1	0.7	0.1	1.25	0.9	0.1	1.6	1.1	0.1				
1.6	1.1	0.3	2	1.5	0.4	2.5	1.8	0.5	3.2	2.4	0.6				
5,970	9,950	9,950	4,780	7,960	7,960	3,820	6,370	6,370	3,180	5,310	5,310				アルミニウム 合金鋳物 Cast aluminum alloys AC4A, ADC12等
300	500	500	300	500	500	300	500	500	300	500	500				
2,990	7,960	4,980	2,390	6,370	3,980	1,910	6,370	6,370	1,590	5,310	6,370				
0.25	0.4	0.25	0.25	0.4	0.25	0.25	0.5	0.5	0.25	0.5	0.6				
0.8	0.6	0.1	1	0.7	0.1	1.25	0.9	0.1	1.6	1.1	0.1				
1.6	1.1	0.3	2	1.5	0.4	2.5	1.8	0.5	3.2	2.4	0.6				
1,990	2,990	6,970	1,590	2,390	6,370	1,270	1,910	5,730	1,060	1,590	5,310	1,000	1,490	4,980	焼入れ鋼 45~55HRC Hardened steels
100	150	350	100	150	400	100	150	450	100	150	500	100	150	500	
480	1,440	4,180	380	1,150	5,100	310	920	5,730	250	760	6,370	240	720	5,980	
0.12	0.24	0.3	0.12	0.24	0.4	0.12	0.24	0.5	0.12	0.24	0.6	0.12	0.24	0.6	
0.8	0.6	0.1	1	0.7	0.1	1.25	0.9	0.1	1.6	1.1	0.1	1.6	1.1	0.1	
1.6	1.1	0.3	2	1.5	0.4	2.5	1.8	0.5	3.2	2.4	0.6	3.2	2.4	0.6	
1,590	2,390	5,570	1,270	1,910	5,100	1,020	1,530	4,590	850	1,270	4,240	800	1,190	3,980	焼入れ鋼 55~62HRC Hardened steels
80	120	280	80	120	320	80	120	360	80	120	400	80	120	400	
380	1,150	3,340	300	920	4,080	240	730	4,590	200	610	5,090	190	570	4,780	
0.12	0.24	0.3	0.12	0.24	0.4	0.12	0.24	0.5	0.12	0.24	0.6	0.12	0.24	0.6	
0.8	0.6	0.1	1	0.7	0.1	1.25	0.9	0.1	1.6	1.1	0.1	1.6	1.1	0.1	
1.6	1.1	0.3	2	1.5	0.4	2.5	1.8	0.5	3.2	2.4	0.6	3.2	2.4	0.6	
< 1.0			< 1.0			< 1.0			< 1.0			< 1.0			最大 fz Maximum fz (mm/t)
< 8.0			< 10.0			< 12.5			< 15.0			< 16.0			最大 ap Maximum ap (mm)

※突き出し長3DC以上の場合は、
上記の表をもとに右記表を参考に
調整してください。

If overhang length is 3DC or more, make
adjustments to the table above according to
the table at right.

突き出し量 Overhang	Vc (m/min)	vf (mm/min)
<3DC	100%	100%
3DC~5DC	70%	70%
5DC~8DC	60%	60%
8DC~10DC	50%	50%

01 従来品との切削抵抗の比較

Comparison of cutting force between conventional edge shape and high helix one.

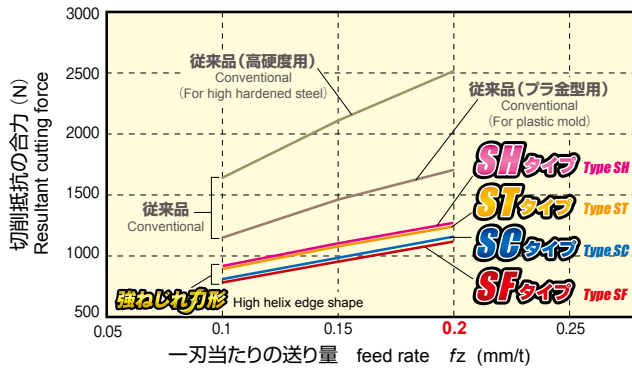

切削条件 Cutting conditions

被削材 Work material : S50C (220HB)
 使用工具 Tool : 刃径φ30 Diameter φ30
 $v_c = 200\text{m/min}$ $f_z = 0.1, 0.15, 0.2\text{mm/t}$
 軸方向切込み Axial depth of cut (a_p) = 15mm
 径方向切込み Radial depth of cut (a_e) = 0.5mm

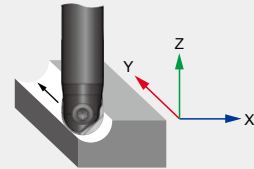

SH
タイプ

Type SH

02 強断続テストによる先端チゼル部の強度比較

Strength comparison of tip chisel by heavy interrupted cutting test

ZPFG-SH (強ねじれ刃形) High helix edge shape



従来品 Conventional

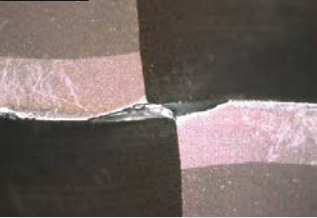

切削条件 Cutting conditions

被削材 Work material : SKD11 (60HRC)
 使用工具 Tool : ABPFM25 (刃径φ25 Diameter φ25)
 シャンク Shank : ASC25-12.5-265-145 (突出し量 Overhang : 183mm)
 $v_c = 314\text{m/min}$ ($n = 4,000\text{min}^{-1}$)
 $f_z = 0.7\text{mm/t}$ ($v_f = 5,600\text{mm/min}$)
 軸方向切込み Axial depth of cut (a_p) = 0.5mm
 径方向切込み Radial depth of cut (a_e) = 1.0mm
 エアー Air



ST
タイプ

Type ST

ZDFG-ST (強ねじれ刃形) High helix edge shape

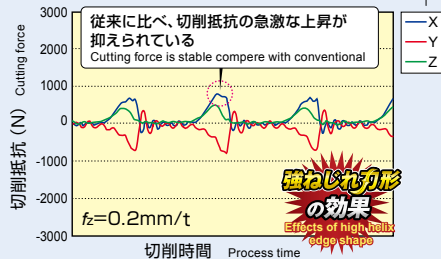

従来品 (高硬度用) Conventional (For high hardness)

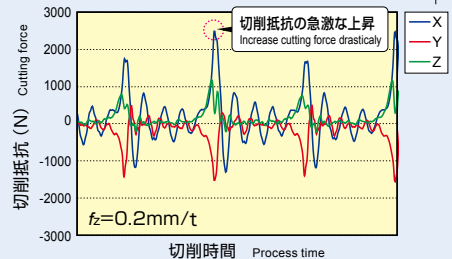

SG
タイプ

Type SG

03 SC タイプとソリッドエンドミルの比較

Comparison of performance with solid end mill and type SC

ZDFG-SG (強ねじれ刃形) High helix edge shape

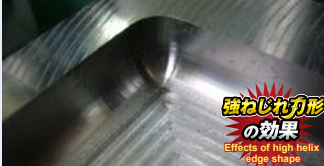

ソリッドエンドミル solid end mill



強ねじれ刃形の効果で切くす排油性が改善。
 中荒加工時でも良好な加工面。
 Improves chip discharge performance by high helix edge shape.
 Good cutting surface on semi-finishing process.

切削条件 Cutting conditions

被削材 Work material : S50C (220HB)
 使用工具 Tool : 刃径φ10 Diameter φ10
 $v_c = 200\text{m/min}$ ($n = 6,366\text{min}^{-1}$)
 $f_z = 0.1\text{mm/t}$ ($v_f = 1,273\text{mm/min}$)
 軸方向切込み Axial depth of cut (a_p) = 0.5mm
 径方向切込み Radial depth of cut (a_e) = 2.0mm
 エアー Air

SF
タイプ

Type SF

04 SF タイプとの加工面の比較

Comparison of cutting surface with type SF and conventional

ZDFG-SF (強ねじれ刃形) High helix edge shape



Ry=4.85μm

従来品 Conventional



Ry=6.51μm

切削条件 Cutting conditions

被削材 Work material : FCD700
 使用工具 Tool : ABPFM30 (刃径φ30) Diameter φ30
 シャンク Shank : ASC32-17-260-140 (突出し量 Overhang : 200mm)
 使用機械 Machine : 縦型 Vertical type (BT50)
 $v_c = 800\text{m/min}$ $f_z = 0.47\text{mm/t}$
 径方向切込み Radial depth of cut (a_e) = 0.3mm
 ピックフィード Pick feed (pf) = 0.5mm
 加工形状 Cutting shape : 5° 傾斜面 5° sloped surface

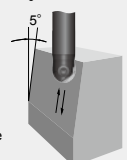

切削事例

Field data

01 SKD11 [60HRC]におけるVc-T線図

Vc-T chart for SKD11 (60HRC)

SHタイプ Type SH

切削条件 Cutting conditions
被削材 Work material: SKD11 (60HRC)
使用工具 Tool: ABPF25S25W100
使用インサート Insert: ZPFG250-SH (TH303)
突出し量 Overhang: 120mm
一刃当りの送り量 Feed rate: $f_z = 0.4\text{mm/t}$
切込み Radial depth of cut: $ap \times ae = 0.3 \times 0.1\text{mm}$, $ap \times ae = 0.3 \times 0.5\text{mm}$
使用機械 Machine: 縦型 Vertical type (BT50)
加工形状 Cutting shape: 5° 傾斜面等高線加工 contouring cutting on the sloped face 5°
エア Air

02 SKD11 [60HRC]におけるVc-T線図

Vc-T chart for SKD11 (60HRC)

STタイプ Type ST

切削条件 Cutting conditions
被削材 Work material: SKD11 (60HRC)
使用工具 Tool: ABPF30S32W150
使用インサート Insert: ZDFG300-ST (ATH80D)
突出し量 Overhang: 150mm
一刃当りの送り量 Feed rate: $f_z = 0.3\text{mm/t}$
切込み Radial depth of cut: $ap \times ae = 0.3 \times 0.1\text{mm}$
使用機械 Machine: 縦型 Vertical type (BT50)
加工形状 Cutting shape: 5° 傾斜面等高線加工 contouring cutting on the sloped face 5°
エア Air

03 プリハードン鋼 [P21 40HRC]におけるVc-T線図

Vc-T chart for Pre-hardened steel (P21 40HRC)

SGタイプ Type SG

切削条件 Cutting conditions
被削材 Work material: P21 (40HRC)
使用工具 Tool: ABPFM20
使用インサート Insert: ASC20-10.5-120-50Z
シャンク Shank: ZDFG200-SC (PN08M)
突出し量 Overhang: 100mm
一刃当りの送り量 Feed rate: $f_z = 0.3\text{mm/t}$
切込み Radial depth of cut: $ap \times ae = 0.3 \times 0.1\text{mm}$, $ap \times ae = 0.5 \times 0.5\text{mm}$
使用機械 Machine: 縦型 Vertical type (BT50)
加工形状 Cutting shape: 5° 傾斜面等高線加工 contouring cutting on the sloped face 5°
エア Air

04 FCD700におけるVc-T線図

Vc-T chart for FCD700

SFタイプ Type SF

切削条件 Cutting conditions
被削材 Work material: FCD700
Vc = 変化 Variable
一刃当りの送り量 Feed rate: $f_z = 0.47\text{mm/t}$
使用機械 Machine: 縦型 Vertical type (BT50)
使用工具 Tool: ABPFM30 (刃径φ30) Diameter φ30
シャンク Shank: ASC32-17-260-140 (突出し量 Overhang: 200mm)
使用インサート Insert: ZDFG300-SF (ATH10E)
径方向切込み Radial depth of cut (ae) = 0.15, 0.3mm
ピックフィード Pick feed (pf) = 0.5mm
加工形状 Cutting shape: 5° 傾斜面 5° sloped surface
エア Air

強ねじれ刃形への切り替え対照表

Comparative table of the conventional and new items.

○は数字が入ります。

Numeric figure comes in a circle ○.

一般刃形インサート Conventional		刃径 Diameter	強ねじれ刃形インサート High helix edge shape inserts	
商品コード Item code	材種 Grade		商品コード Item code	材種 Grade
ZPFG○○○	PTH08M	(φ8 ~ 30)	ZDFG○○○-ST	ATH80D
ZPFG○○○	PCA08M		ZDFG○○○-SC	PN08M
ZPFG○○○	PCA12M		ZDFG○○○-ST	PN15M
ZPFG○○○-GH	ATH80D	(φ8 ~ 30)	ZPFG○○○-SH	TH303
ZPFG○○○-GF	ACS05E		ZDFG○○○-SC	PN08M
ZPFG○○○-GF	HD7010		ZDFG○○○-SF	HD7010
ZDFG○○○-WH	ATH80D	(φ6 ~ 30)	ZDFG○○○-ST	ATH80D
ZDFG○○○-WF	ACS05E		ZDFG○○○-SC	PN08M
	ACS05E		ZDFG○○○-SF	ATH10E

実績は語る

Field Data

加工事例 Cutting examples	切削条件 Cutting Conditions	結果 Result
<p>フレームハード鋼 (表面55~60HRC) の加工</p> <p>Frame hard steels (surface 55~60HRC)</p>	<p>使用工具 Tool: ABPF25S25W100 被削材 Work material: フレームハード鋼 (表面55~60HRC) Frame hard steels (surface 55~60HRC)</p> <p>使用インサート Insert: ZDFG250-ST (ATH80D)</p> <p>使用機械 Machine: 門型 Gate type M/C (BT50)</p> <p>切削速度 Cutting speed: $V_c = 393\text{m/min}$ 回転数 Revolution: $n = 5,000\text{min}^{-1}$</p> <p>送り速度 Feed rate: $V_f = 5,200\text{mm/min}$ 一刃当りの送り量 Feed rate: $f_z = 0.52\text{mm/t}$</p> <p>切込み深さ Depth of cut: $ap = 0.1\text{mm}$ ピックフィード Pick feed: $ae = 0.5\text{mm}$ 切削油剤 Coolant: 乾式 Dry</p>	<p>11時間使用し刃先は定常摩耗にて良好。従来品に対し面粗さも良好。</p> <p>Still normal wear even after 11 hours process. Improves the surface roughness than conventional.</p>
<p>プラスチック金型 (S50C) の加工</p> <p>Plastic mold (S50C)</p>	<p>使用工具 Tool: ABPF20S20W100 被削材 Work material: S50C</p> <p>使用インサート Insert: ZDFG200-SC (PN08M)</p> <p>使用機械 Machine: 横型 Horizontal type M/C (BT50)</p> <p>切削速度 Cutting speed: $V_c = 251\text{m/min}$ 回転数 Revolution: $n = 4,000\text{min}^{-1}$</p> <p>送り速度 Feed rate: $V_f = 2,000\text{mm/min}$ 一刃当りの送り量 Feed rate: $f_z = 0.25\text{mm/t}$</p> <p>切込み深さ Depth of cut: $ap = 0.1\text{mm}$ ピックフィード Pick feed: $ae = 0.4\text{mm}$ 切削油剤 Coolant: 乾式 Dry</p>	<p>15時間使用し、刃先は定常摩耗。従来品と比較し仕上げ面粗さも良好。</p> <p>Still normal wear even after 15 hours process. Improves the surface roughness than conventional.</p>
<p>プレス型 (FCD700相当) の加工</p> <p>Press die (as FCD700)</p>	<p>使用工具 Tool: ABPF30S32W120 被削材 Work material: FCD700相当 Material equivalent to FCD700</p> <p>使用インサート Insert: ZDFG300-SF (ATH10E)</p> <p>使用機械 Machine: 門型 Gate type M/C (BT50)</p> <p>切削速度 Cutting speed: $V_c = 510\text{m/min}$ 回転数 Revolution: $n = 5,400\text{min}^{-1}$</p> <p>送り速度 Feed rate: $V_f = 4,500\text{mm/min}$ 一刃当りの送り量 Feed rate: $f_z = 0.42\text{mm/t}$</p> <p>切込み深さ Depth of cut: $ap = 0.2\text{mm}$ ピックフィード Pick feed: $ae = 0.5\text{mm}$ 切削油剤 Coolant: 乾式 Dry</p>	<p>仕上げ面良好。刃先摩耗のバラツキが少なく再研磨も可能。</p> <p>Finished surface is fine. Re-grinding is possible by normal wear after process.</p>
<p>鍛造金型の加工</p> <p>Forging die</p>	<p>使用工具 Tool: ABPF12S12W 被削材 Work material: SKD61 (45HRC)</p> <p>使用インサート Insert: ZDFG120-ST (PN15M)</p> <p>使用機械 Machine: 縦型 Vertical type M/C (BT50)</p> <p>切削速度 Cutting speed: $V_c = 94\text{m/min}$ 回転数 Revolution: $n = 2,500\text{min}^{-1}$</p> <p>送り速度 Feed rate: $V_f = 800\text{mm/min}$ 一刃当りの送り量 Feed rate: $f_z = 0.16\text{mm/t}$</p> <p>切込み深さ Depth of cut: $ap = 0.3 \sim 0.5\text{mm}$ ピックフィード Pick feed: $ae = 0.5\text{mm}$ 切削油剤 Coolant: 乾式 Dry</p>	<p>工具突出し60mm (L/D: 5) の加工であるが、PN15M の損傷は定常摩耗形態を示し良好。</p> <p>Normal wear after overhang cutting (60mm L/D: 5)</p>
<p>グラファイト電極の加工</p> <p>Machining of graphite electrodes</p>	<p>使用工具 Tool: ABPF10S10W 被削材 Work material: グラファイト Graphite</p> <p>使用インサート Insert: ZDFG100-SF (HD7010)</p> <p>使用機械 Machine: 縦型 Vertical type M/C (BT40)</p> <p>切削速度 Cutting speed: $V_c = 251\text{m/min}$ 回転数 Revolution: $n = 8,000\text{min}^{-1}$</p> <p>送り速度 Feed rate: $V_f = 600\text{mm/min}$ 一刃当りの送り量 Feed rate: $f_z = 0.038\text{mm/t}$</p> <p>切込み深さ (荒加工) Depth of cut (Rough): $ap = 3\text{mm}$ (仕上げ Finishing): $ap = 0.3\text{mm}$</p> <p>ピックフィード (荒加工) Pick feed (Rough): $ae = 4\text{mm}$ (仕上げ Finishing): $ae = 0.1\text{mm}$ 切削油剤 Coolant: 乾式 Dry</p>	<p>工具突出し75mm (L/D: 7.5) の加工でも、荒加工が安定したことで仕上げ面精度良好。</p> <p>Even for tool projection of 75mm (L/D: 7.5), roughing was stable resulting in good finished surface accuracy.</p>
<p>ダクタイル鋳鉄+フレームハード鋼の加工</p> <p>Ductile cast iron and frame hard steels</p>	<p>使用工具 Tool: ABPF30S32W150 被削材 Work material: ダクタイル鋳鉄+フレームハード鋼 Ductile cast iron and frame hard steels (55HRC)</p> <p>使用インサート Insert: ZPFG300-SH (TH303)</p> <p>使用機械 Machine: 門型 Gate type M/C (BT50)</p> <p>切削速度 Cutting speed: $V_c = 471\text{m/min}$ 回転数 Revolution: $n = 5,000\text{min}^{-1}$</p> <p>送り速度 Feed rate: $V_f = 5,000\text{mm/min}$ 一刃当りの送り量 Feed rate: $f_z = 0.5\text{mm/t}$</p> <p>切込み深さ Depth of cut: $ap = 0.2\text{mm}$ ピックフィード Pick feed: $ae = 2\text{mm}$ 切削油剤 Coolant: エア Air</p>	<p>中仕上げ加工は、工具寿命が安定しなかった。SH (TH303) は、中仕上げ加工でも定常摩耗にて良好。次工程の仕上げ精度も安定化した。</p> <p>SH (TH303) performed well with steady wear even in semi-finishing which conventional tool life was unstable. Finishing accuracy of next process was also stabilized.</p>
<p>SKD11 (60HRC) の加工</p> <p>SKD11 (60HRC)</p>	<p>使用工具 Tool: ABPF30S32W120 被削材 Work material: SKD11 (60HRC)</p> <p>使用インサート Insert: ZPFG300-SH (TH303)</p> <p>使用機械 Machine: 縦型 Vertical type M/C (BT50)</p> <p>切削速度 Cutting speed: $V_c = 377\text{m/min}$ 回転数 Revolution: $n = 4,000\text{min}^{-1}$</p> <p>送り速度 Feed rate: $V_f = 3,000\text{mm/min}$ 一刃当りの送り量 Feed rate: $f_z = 0.38\text{mm/t}$</p> <p>切込み深さ Depth of cut: $ap = 0.2\text{mm}$ ピックフィード Pick feed: $ae = 0.6\text{mm}$ 切削油剤 Coolant: 乾式 Dry</p>	<p>従来は条件を落として加工していた。SH (TH303) にすることで工具寿命が安定し加工効率を上げることができた。仕上げ面粗さも良好。</p> <p>SH (TH303) stabilized tool life and could increase efficiency even in semi-finishing which conventional tool had to reduce cutting conditions. Finishing surface roughness is also good.</p>



図、表等のデータは試験結果の一例であり、保証値ではありません。
「MOLDINO」は株式会社MOLDINOの登録商標です。

The diagrams and table data are examples of test results, and are not guaranteed values.
"MOLDINO" is a registered trademark of MOLDINO Tool Engineering, Ltd.

安全上のご注意 Attention on Safety

1. 取扱上のご注意

- (1) 工具をケース(梱包)から取り出す際は、足元への落下あるいは素手の指先へ落ちて怪我をしないように十分なご注意をお願いします。
- (2) インサートをセットして実際にご使用の場合は、切れ刃を素手で直接触れないように注意してください。

2. 取付け時のご注意

- (1) ご使用にあたって、インサートのセッティングは確実に行っていただき、アール等への取付けも確실히行ってください。
- (2) ご使用中に、異常な振動等が発生した場合は、直ちに機械を停止させて、その振動の原因を除いてください。

3. 使用上のご注意

- (1) 切削工具あるいは被削材の寸法・回転の方向は、あらかじめ確認しておいてください。
- (2) 標準切削条件の数値は、新しい作業の立上げの目安としてご利用ください。切込みが大きい場合、使用機械の剛性が小さい場合あるいは被加工物の性状に応じて切削条件を適正に調整してご使用ください。
- (3) インサートは硬質の材料です。ご使用中に破損して飛散する場合があります。また、切りくずが飛散することがあります。これらの飛散物等は作業者を切傷させ、火傷あるいは目に入って負傷させる恐れがありますので、工具をご使用中はその周囲に安全カバーを取付け、保護メガネ等の保護具を着用して安全な環境下での作業をお願いします。
 - ・引火や爆発の危険のあるところでは使用しないでください。
 - ・不水溶性切削油は、火災の恐れがありますので使用しないでください。
- (4) 工具を本来の目的以外に使用したり、改造したりしないでください。

4. 工具に関して、安全上の問題点・不明の点・その他ご相談がありましたらフリーダイヤル技術相談へお問い合わせください。

1. Attention regarding handling

- (1) When removing the tool from the case (package), be careful not to drop it on your foot or drop it onto the tips of your bare fingers.
- (2) When actually setting the inserts, be careful not to touch the cutting flute directly with your bare hands.

2. Attention regarding mounting

- (1) When preparing for use, be sure that the inserts are firmly mounted in place and that they are firmly mounted on the arbor, etc.
- (2) If abnormal chattering occurs during use, stop the machine immediately and remove the cause of the chattering.

3. Attention during use

- (1) Before use, confirm the dimensions and direction of rotation of the tool and milling work material.
- (2) The numerical values in the standard cutting conditions table should be used as criteria when starting new work. The cutting conditions should be adjusted as appropriate when the cutting depth is large, the rigidity of the machine being used is low, or according to the conditions of the work material.
- (3) The inserts are made of a hard material. During use, they may break and fly off. In addition, cutting chips may also fly off. Since there is a danger of injury to workers, fire, or eye damage from such flying pieces, a safety cover should be installed and safety equipment such as safety glasses should be worn to create a safe environment for work.
 - ・ Do not use where there is a risk of fire or explosion.
 - ・ Do not use non-water-soluble cutting oils. Such oils may result in fire.
- (4) Do not use the tool for any purpose other than that for which it is intended, and do not modify it.

株式会社 MOLDINO

MOLDINO Tool Engineering, Ltd.

本社 〒130-0026 東京都墨田区両国4-31-11(ヒューリック両国ビル8階)
☎ 03-6890-5101 FAX 03-6890-5134
International Sales Dept.: ☎ +81-3-6890-5103 FAX +81-3-6890-5128

営業企画部	☎ 03-6890-5102 FAX03-6890-5134	海外営業部	☎ 03-6890-5103 FAX03-6890-5128
東京営業所	☎ 03-6890-5110 FAX03-6890-5133	静岡営業所	☎ 054-273-0360 FAX054-273-0361
東北営業所	☎ 022-208-5100 FAX022-208-5102	名古屋営業所	☎ 052-687-9150 FAX052-687-9144
新潟営業所	☎ 0258-87-1224 FAX0258-87-1158	大阪営業所	☎ 06-7668-0190 FAX06-7668-0194
東関東営業所	☎ 0294-88-9430 FAX0294-88-9432	中四営業所	☎ 082-536-2001 FAX082-536-2003
長野営業所	☎ 0268-21-3700 FAX0268-21-3711	九州営業所	☎ 092-289-7010 FAX092-289-7012
北関東営業所	☎ 0276-59-6001 FAX0276-59-6005		
神奈川営業所	☎ 046-400-9429 FAX046-400-9435		

ヨーロッパ / MOLDINO Tool Engineering Europe GmbH Itterpark 12, 40724 Hilden, Germany. TEL : +49-(0)2103-24820. FAX : +49-(0)2103-248230
 アメリカ / MITSUBISHI MATERIALS U.S.A. CORPORATION 41700 Gardenbrook Road, Suite 120, Novi, MI 48375-1320 U.S.A. TEL : +1(248)308-2620. FAX : +1(248)308-2627
 メキシコ / MMC METAL DE MEXICO, S.A. DE C.V. Av. La Cañada No.16, Parque Industrial Bernardo Quintana, El Marques, Querétaro, CP 76246, México TEL : +52-442-1926800
 ブラジル / MMC METAL DO BRASIL LTDA. Rua Cincinato Braga, 340 13° andar, Bela Vista - CEP 01333-010 São Paulo - SP., Brasil TEL : +55(11)3506-5600 FAX : +55(11)3506-5677
 タイ / MMC Hardmetal (Thailand) Co., Ltd. MOLDINO Division 622 Emporium Tower, Floor 22/14, Sukhumvit Road, Klong Tan, Klong Toei, Bangkok 10110, Thailand TEL: +66-(0)2-661-8175 FAX: +66-(0)2-661-8176
 インド / MMC Hardmetal India Pvt Ltd. H.O.: Prasad Enclave, #118/119, 1st Floor, 2nd Stage, 5th main, BSMF Ward #11, (New #38), Industrial Suburb, Yeshwanthpura, Bengaluru, 560 022, Karnataka, India. TEL : +91-80-2204-3600

ホームページ フリーダイヤル技術相談

http://www.moldino.com ☎ 0120-134159

工具選定データベース [TOOL SEARCH]

TOOLSEARCH

検索

店名

VISI INDOTAMA SEJAHTERA
0811330377 (WA)
081217801333 (WA)
www.visiindotama.com

掲載価格は2022年10月1日改定後の消費税抜きの単価を表示しております。予告なく改良・改善のために仕様変更することがあります。
Specifications for the products listed in this catalog are subject to change without notice due to replacement or modification.

VEGETABLE OIL INK ベジタブルインクで印刷しています。 Printed using vegetable oil ink.

2023-6 (ME-GT3)
Printed in JAPAN 2013-12:FP