

Standardised Water Pump

WKLn

Installation/Operating Manual

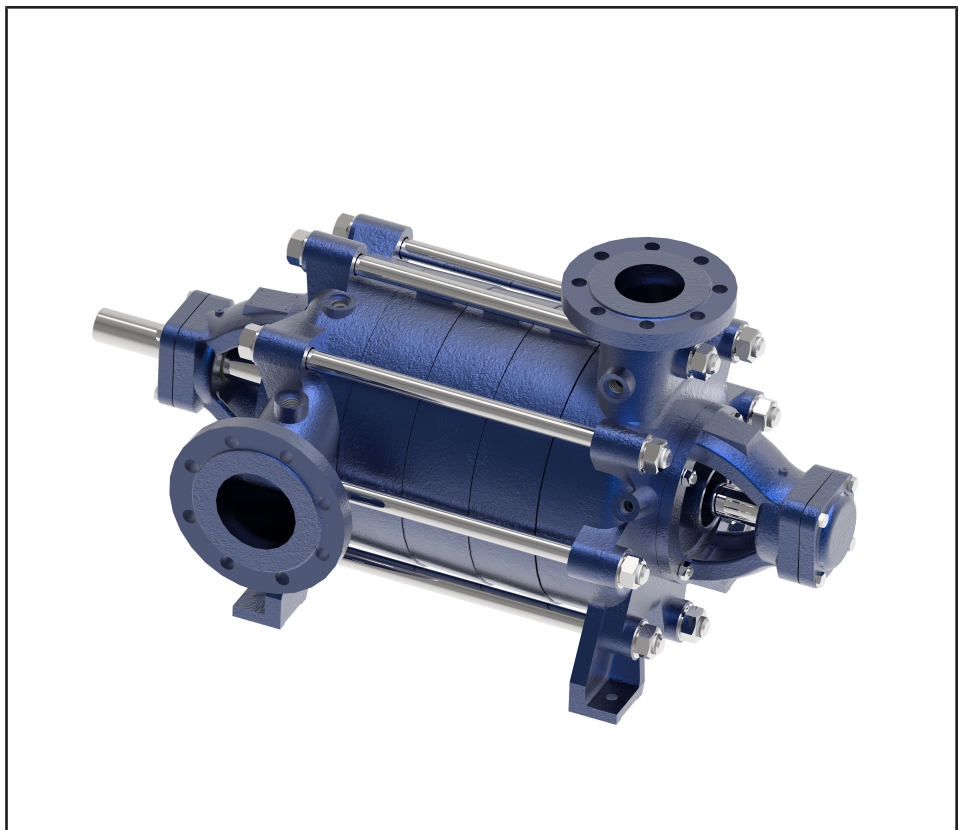

Legal information/Copyright

Installation/Operating Manual WKLn

Original operating manual

All rights reserved. The contents provided herein must neither be distributed, copied, reproduced, edited or processed for any other purpose, nor otherwise transmitted, published or made available to a third party without the manufacturer's express written consent.

Subject to technical modification without prior notice.

© KSB SE & Co. KGaA, Frankenthal 04/06/2018

Contents

1.	Safety	4
1.1	General	4
1.2	Intended use	4
1.3	Personnel qualification and training	4
1.4	Consequences and risks caused by non-compliance with this manual	5
1.5	Safety awareness	5
1.6	Safety information for the operator/user	5
1.7	Safety information for maintenance, inspection and installation	5
1.8	Unauthorised modes of operation	6
1.9	Key to safety symbols/markings	6
2.	Transport /Temporary Storage /Disposal	7
2.1	Checking the condition upon delivery	7
2.2	Transport	7
2.3	Storage / preservation	9
2.4	Return to supplier	9
2.5	Disposal	10
3.	Installation at Site	11
3.1	Safety regulations	11
3.2	Mounting	12
3.3	Setting up the pump set	12
3.4	Alignment of Pump and Driver	13
3.5	Connecting the Piping	14
3.6	Auxiliary connections	15
3.7	Vacuum Balance Line	16
3.8	Minimum Flow	16
3.9	Coupling Guard	16
3.10	Final Check	16
4.	Start-up / Commissioning, Shutdown	17
4.1	Preparations	17
4.1.1	Lubricants	17
4.1.2	Shaft Seal	17
4.1.3	Priming the Pump and associated Checks	17
4.1.4	Checking the Direction of Rotation	17
4.2	Start-up	18
4.3	Shutdown	19
5.	Maintenance and Lubrication	20
5.1	Supervision of operation	20
5.2	Lubrication and Grease Change	20
5.2.2	Grease Change	20
6.	Dismantling and Reassembly	22
6.1	General	22
6.2.1	Mechanical Seal	22
6.3	Bearings	23
6.4	Assembly	24
6.4.1	Pump	24
6.4.2	Shaft Seal	26
6.4.2.1	Packed Gland	26
6.4.2.2	Mechanical Seal	28
6.4.3	Setting Torques for the Tie bolts	28
6.5	Cooling Liquid (HW Design)	28
6.6	External Source Sealing Liquid (Vacuum Operation)	28
6.7	Spare Parts	29
6.7.1	Recommended List of Spare Parts	29
6.7.2	Alternatively keeping a complete Rotor in stock comprising:	29
6.8	Exploded Views and List of components	30
6.9	Faults	32

1. Safety

All the information contained in this section refers to hazardous situations.

In addition to the present general safety information the action-related safety information given in the other sections must be observed.

1.1 General

This operating manual contains general installation, operating and maintenance instructions that must be observed to ensure safe operation of the system and prevent personal injury and damage to property.

The safety information in all sections of this manual must be complied with.

The operating manual must be read and understood by the responsible specialist personnel/operators prior to installation and commissioning.

The contents of this operating manual must be available to the specialist personnel at the site at all times.

Information attached directly to the product must always be complied with and kept in a perfectly legible condition at all times. This applies to, for example:

- Arrow indicating the direction of rotation
- Markings for connections
- Name plate

The operator is responsible for ensuring compliance with all local regulations not taken into account in this operating manual.

1.2 Intended use

- The pump (set) must only be operated in the fields of application and within the use limits specified in the other applicable documents.
- Only operate pumps/pump sets which are in perfect technical condition.
- Do not operate the pump (set) in partially assembled condition.
- Only use the pump to handle the fluids described in the data sheet or product literature of the pump model or variant.
- Never operate the pump without the fluid to be handled.
- Observe the minimum flow rates indicated in the data sheet or product literature (to prevent overheating, bearing damage, etc).
- Observe the minimum flow rate and maximum flow rate indicated in the data sheet or product literature (to prevent overheating, mechanical seal damage, cavitation damage, bearing damage, etc).
- Do not throttle the flow rate on the suction side of the pump (to prevent cavitation damage).
- Consult the manufacturer about any use or mode of operation not described in the data sheet or product literature.

1.3 Personnel qualification and training

All personnel involved must be fully qualified to transport, install, operate, maintain and inspect the machinery this manual refers to.

The responsibilities, competence and supervision of all personnel involved in transport, installation, operation, maintenance and inspection must be clearly defined by the operator.

Deficits in knowledge must be rectified by means of training and instruction provided by sufficiently trained specialist personnel. If required, the operator can commission the manufacturer/supplier to train the personnel.

Training on the pump (set) must always be supervised by technical specialist personnel.

1.4 Consequences and risks caused by non-compliance with this manual

- Non-compliance with these operating instructions will lead to forfeiture of warranty cover and of any and all rights to claims for damages.
- Non-compliance can, for example, have the following consequences:
 - Hazards to persons due to electrical, thermal, mechanical and chemical effects and explosions
 - Failure of important product functions
 - Failure of prescribed maintenance and servicing practices
 - Hazard to the environment due to leakage of hazardous substances

1.5 Safety awareness

In addition to the safety information contained in this manual and the intended use, the following safety regulations shall be complied with:

- Accident prevention, health regulations and safety regulations
- Explosion protection regulations
- Safety regulations for handling hazardous substances
- Applicable standards, directives and laws

1.6 Safety information for the operator/user

- Fit protective equipment (e.g. contact guards) supplied by the operator for hot, cold or moving parts, and check that the equipment functions properly.
- Do not remove any protective equipment (e.g. contact guards) during operation.
- Provide the personnel with protective equipment and make sure it is used.
- Contain leakages (e.g. at the shaft seal) of hazardous fluids handled (e.g. explosive, toxic, hot) so as to avoid any danger to persons and the environment. Adhere to all relevant laws.
- Eliminate all electrical hazards. (In this respect refer to the applicable national safety regulations and/or regulations issued by the local energy supply companies.)
- If shutting down the pump does not increase potential risk, fit an emergency-stop control device in the immediate vicinity of the pump (set) during pump set installation.

1.7 Safety information for maintenance, inspection and installation

- Modifications or alterations of the pump (set) are only permitted with the manufacturer's prior consent.
- Use only original spare parts or parts/components authorised by the manufacturer. The use of other parts/components can invalidate any liability of the manufacturer for resulting damage.
- The operator ensures that maintenance, inspection and installation is performed by authorised, qualified specialist personnel who are thoroughly familiar with the manual.
- Only carry out work on the pump (set) during standstill of the pump.
- Only perform work on the pump set when it has been disconnected from the power supply (de-energised).
- The pump (set) must have cooled down to ambient temperature.
- Pump pressure must have been released and the pump must have been drained.
- Decontaminate pumps which handle fluids posing a health hazard.
- As soon as the work has been completed, re-install and re-activate any safety-relevant devices and protective devices. Before returning the product to service, observe all instructions on commissioning.







1.8 Unauthorised modes of operation

Never operate the pump (set) outside the limits stated in the data sheet and in this manual.

The warranty relating to the operating reliability and safety of the supplied pump (set) is only valid if the equipment is used in accordance with its intended use.

1.9 Key to safety symbols/markings

Table 3: Definition of safety symbols/markings

Symbol	Description
	DANGER This signal word indicates a high-risk hazard which, if not avoided, will result in death or serious injury.
	WARNING This signal word indicates a medium-risk hazard which, if not avoided, could result in death or serious injury.
	CAUTION This signal word indicates a hazard which, if not avoided, could result in damage to the machine and its functions.
	Explosion protection This symbol identifies information about avoiding explosions in potentially explosive atmospheres in accordance with EU Directive 2014/34/EU (ATEX).
	General hazard In conjunction with one of the signal words this symbol indicates a hazard which will or could result in death or serious injury.
	Electrical hazard In conjunction with one of the signal words this symbol indicates a hazard involving electrical voltage and identifies information about protection against electrical voltage.
	Machine damage In conjunction with the signal word CAUTION this symbol indicates a hazard for the machine and its functions.

2. Transport/Temporary Storage/Disposal

2.1 Checking the condition upon delivery

1. On transfer of goods, check each packaging unit for damage.
2. In the event of in-transit damage, assess the exact damage, document it and notify KSB or the supplying dealer and the insurer about the damage in writing immediately.

2.2 Transport

	DANGER
	<p>The pump (set) could slip out of the suspension arrangement Danger to life from falling parts!</p> <ul style="list-style-type: none"> ▷ Always transport the pump (set) in the specified position. ▷ Never attach the suspension arrangement to the free shaft end or the motor eyebolt and/or the pump. ▷ Observe the information on weights, centre of gravity and fastening points. ▷ Observe the applicable local accident prevention regulations. ▷ Use suitable, permitted lifting accessories, e.g. self-tightening lifting tongs.

Table 3: Transporting the pump set

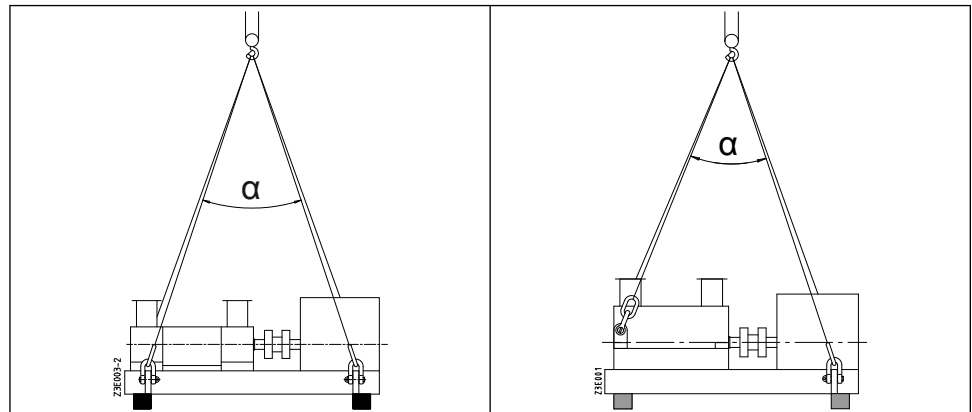

Table 4: Transporting the pump on the baseplate

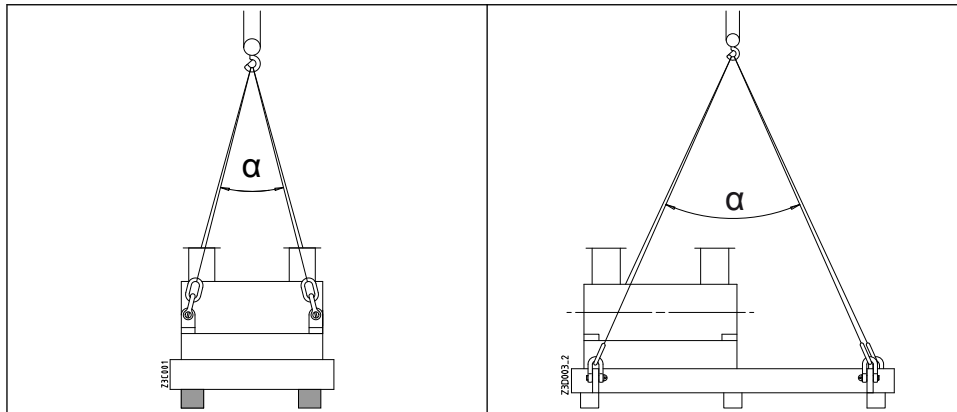

Table 5: Transporting the pump on a transport frame

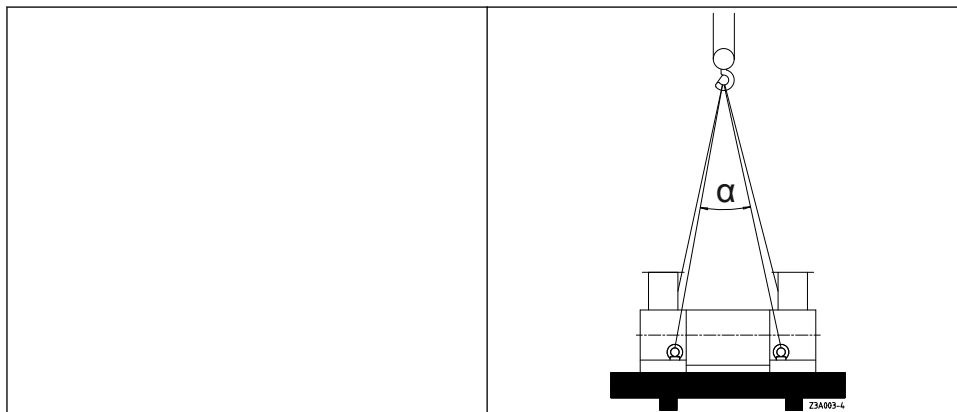

Table 6: Transporting the pump on a transport frame (only if marked accordingly)

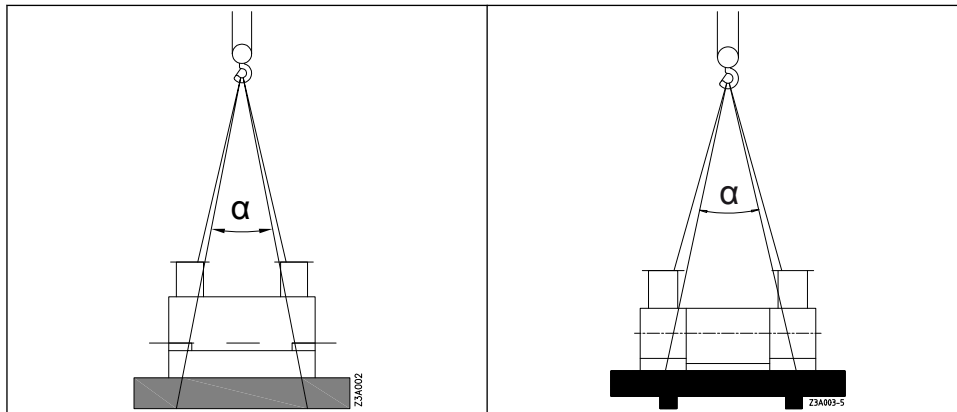
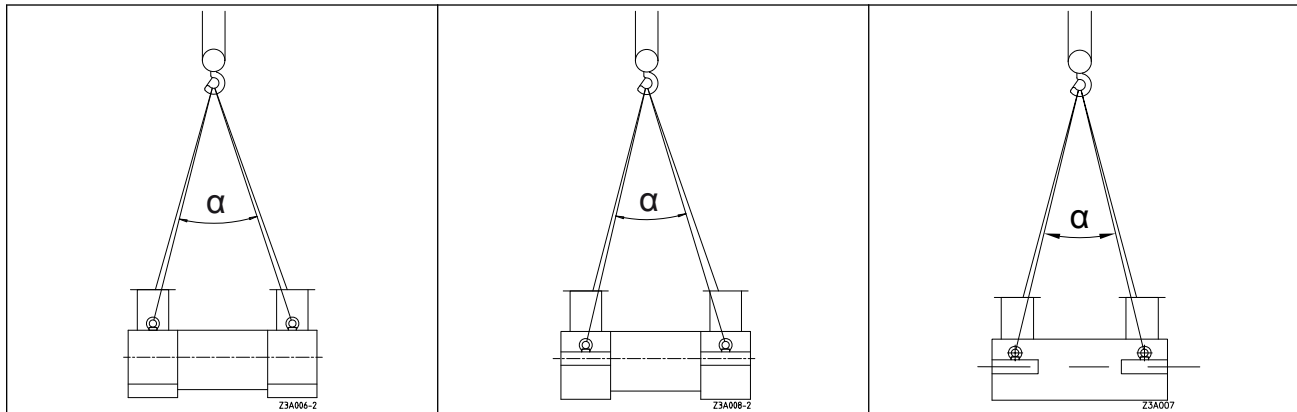



Table 7: Transporting the pump without transport frame



2.3 Storage/preservation

If commissioning is to take place sometime after delivery, we recommend that the following measures be taken for pump (set) storage.

	CAUTION
	<p>Damage during storage due to humidity, dirt or vermin Corrosion/contamination of the pump (set)!</p> <ul style="list-style-type: none"> ▷ For outdoor storage cover the pump (set) or the packaged pump (set) and accessories with waterproof material.
	CAUTION
	<p>Wet, contaminated or damaged openings and connections Leakage or damage to the pump!</p> <ul style="list-style-type: none"> ▷ Clean and cover pump openings and connections as required prior to putting the pump into storage.

Store the pump (set) in a dry, protected room where the atmospheric humidity is as constant as possible.

Rotate the shaft by hand once a month, e.g. via the motor fan.

If properly stored indoors, the pump set is protected for three months.

New pumps/pump sets are supplied by our factory duly prepared for storage.



For storage periods exceeding three months, the pump set is preserved as specified in the purchase order.

2.4 Return to supplier

1. Drain the pump as per operating instructions.
2. Flush and clean the pump, particularly if it has been used for handling noxious, explosive, hot or other hazardous fluids.
3. If the pump has handled fluids whose residues could lead to corrosion damage in the presence of atmospheric humidity or could ignite upon contact with oxygen also neutralise the pump and blow through with anhydrous inert gas to ensure drying.
4. Always complete and enclose a certificate of decontamination when returning the pump.
Indicate any safety measures and decontamination measures taken.

	NOTE
	<p>If required, a blank certificate of decontamination can be downloaded from the following web site: www.ksb.com/certificate_of_decontamination</p>



2.5 Disposal

	 WARNING
	<p>Fluids handled, consumables and supplies which are hot and/or pose a health hazard</p> <p>Hazard to persons and the environment!</p> <ul style="list-style-type: none"> ▸ Collect and properly dispose of flushing fluid and any fluid residues. ▸ Wear safety clothing and a protective mask if required. ▸ Observe all legal regulations on the disposal of fluids posing a health hazard.

1. Dismantle the pump (set).
Collect greases and other lubricants during dismantling.
2. Separate and sort the pump materials, e.g. by:
 - Metals
 - Plastics
 - Electronic waste
 - Greases and other lubricants
3. Dispose of materials in accordance with local regulations or in another controlled manner.

3. Installation at Site

3.1 Safety regulations

	<p>⚠ DANGER</p> <p>Improper installation in potentially explosive atmospheres Explosion hazard! Damage to the pump set!</p> <ul style="list-style-type: none"> ▸ Comply with the applicable local explosion protection regulations. ▸ Observe the information in the data sheet and on the name plates of pump and motor.
	<p>⚠ WARNING</p> <p>Pump with long-term preservation: Harmful preservatives in drinking water systems Danger of poisoning!</p> <ul style="list-style-type: none"> ▸ Flush the system prior to commissioning. ▸ If necessary, dismantle the pump and thoroughly remove the preservative from all wetted components. ▸ Observe the data given in the order confirmation.

3.2 Mounting

Position the pump set on the foundation and align using a precision spirit level (on the shaft/discharge nozzle). Ensure that the gap between the two coupling halves is as given on the general arrangement drawing.

Shims should always be fitted to the left and right of the bolts in close proximity to the bolts, between the baseplate/base frame and foundation. If the bolts are more than 800mm apart, position extra shims equal distant between them. All shims must seat perfectly flush.

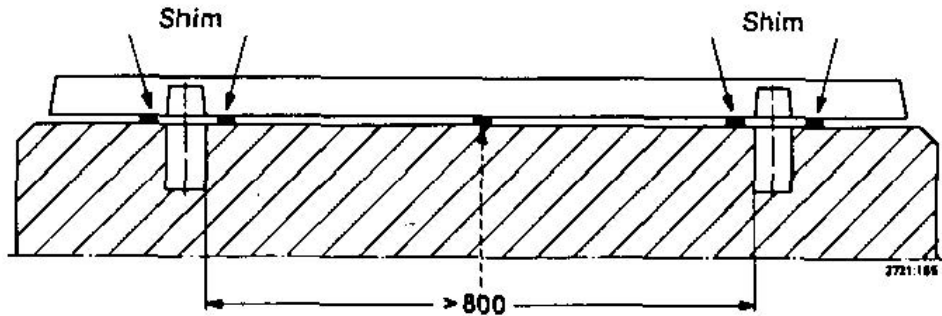

Fig. 2 Fitting shims

Uniformly tighten up the bolts.

Grout in the baseplate (non-shrinking mortar is highly recommended), ensuring no cavities remain.

3.3 Setting up the pump set

	<p style="background-color: #e67e22; color: white; padding: 5px;">⚠ DANGER</p> <p>Static charging due to insufficient potential equalisation Explosion hazard!</p> <ul style="list-style-type: none"> ▷ Make sure that the connection between pump and baseplate is electrically conductive.
	<p style="background-color: #f1c40f; padding: 5px;">CAUTION</p> <p>Warped baseplate or pump Damage to the pump!</p> <ul style="list-style-type: none"> ▷ Align the baseplate and the pump accurately and carefully when installing the pump set. ▷ Ensure the baseplate is flat and level.
	<p style="background-color: #2980b9; color: white; padding: 5px;">NOTE</p> <p>For low-noise operation contact KSB to check whether the pump set can be installed on anti-vibration mounts. In this case, the baseplate should not be grouted.</p>
	<p style="background-color: #2980b9; color: white; padding: 5px;">NOTE</p> <p>Expansion joints can be fitted between the pump and the suction/discharge line.</p>

3.4 Alignment of Pump and Driver

After the baseplates has been fixed in position carefully check the coupling and, if necessary, realign the pump set.

The coupling must also be checked and the pump set realigned even if the pump and driver are supplied ready mounted on a common baseplate.

The pump set can be considered correctly aligned when the gap (a or b, see Fig 3) between each shaft and a straight edge placed axially over both half couplings is the same at all points in the circumference.

Furthermore, the gap between the two coupling halves must be the same at all points on the circumference. This can be measured with callipers or a feeler gauge (see Fig. 3 and 4)

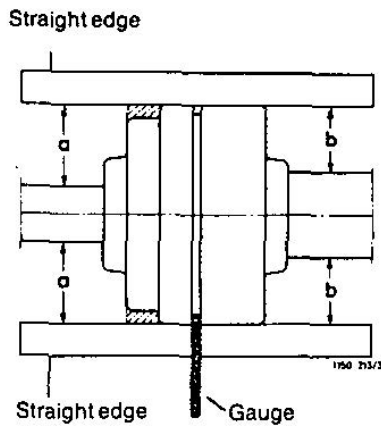

Fig. 3 Aligning a non-spacer type flexible coupling

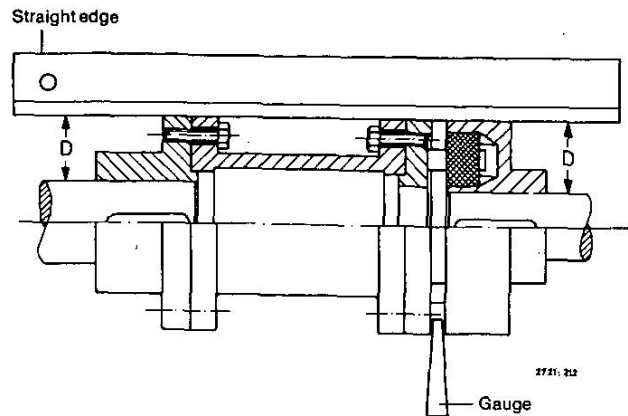

Fig. 4 Aligning a flexible spacer coupling

The axial and radial deviation between the two coupling halves must not exceed 0.1mm.

	<p>⚠ DANGER</p> <p>Inadmissible temperatures at the coupling or bearings due to misalignment of the coupling Explosion hazard! Risk of burns!</p> <p>▷ Make sure that the coupling is correctly aligned at all times.</p>
	<p>CAUTION</p> <p>Misalignment of pump and motor shafts Damage to pump, motor and coupling!</p> <p>▷ Always check the coupling after the pump has been installed and connected to the piping. ▷ Also check the coupling of pump sets supplied with pump and motor mounted on the same baseplate.</p>

3.5 Connecting the Piping

Suction lift lines should be run with a rising slope towards the pump, positive suction lines with a downward slope towards the pump.

The pump must not bear the weight of the piping. The nominal bores of the pipes should be the same as or larger than those of the pump nozzles. We recommend installing non-return devices and shut-off valves, depending on the type of installation.

Before commissioning a new installation, thoroughly clean, flush and blow through all vessels, piping and connections. As welding beads, scale and other impurities frequently only become dislodged after a certain period of time, it is necessary to fit a strainer should be three times the cross-section of the piping in order to avoid excessive pressure loss across the strainer due to clogging.

The conical strainer consists of a coarse strainer fronted by a fine strainer with a 2,0mm mesh and 0,5mm wire, made of corrosion-resistant material. See DIN 4181

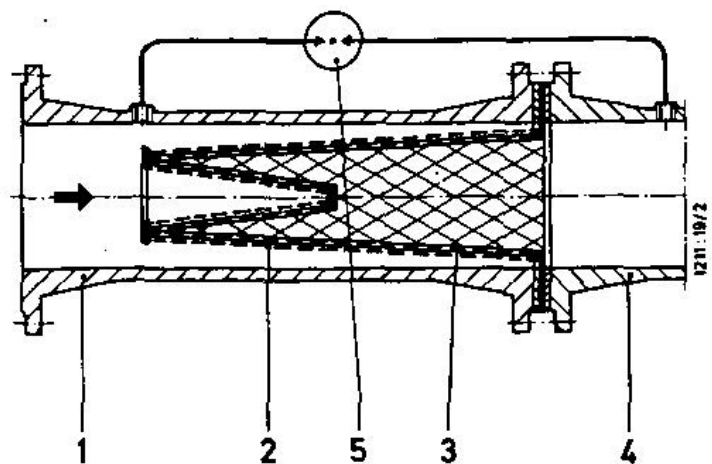

1. Strainer holder
2. Fine strainer
3. Coarse strainer
4. Pump suction nozzle
5. Differential pressure gauge

Fig. 5 Conical strainer for suction line

	<p style="background-color: #e67e22; color: white; padding: 5px;">⚠ DANGER</p> <p>Impermissible loads acting on the pump nozzles Danger to life from escaping hot, toxic, corrosive or flammable fluids!</p> <ul style="list-style-type: none"> ▷ Do not use the pump as an anchorage point for the piping. ▷ Anchor the pipes in close proximity to the pump and connect them properly without transmitting any stresses or strains. ▷ Observe the permissible forces and moments at the pump nozzles. ▷ Take appropriate measures to compensate for thermal expansion of the piping.
	<p style="background-color: #f1c40f; padding: 5px;">CAUTION</p> <p>Incorrect earthing during welding work at the piping Destruction of rolling element bearings (pitting effect)!</p> <ul style="list-style-type: none"> ▷ Never earth the electric welding equipment on the pump or baseplate. ▷ Prevent current flowing through the rolling element bearings.
	<p style="background-color: #2980b9; color: white; padding: 5px;">NOTE</p> <p>Installing check and shut-off elements in the system is recommended, depending on the type of plant and pump. However, such elements must not obstruct proper drainage or hinder disassembly of the pump.</p>

3.6 Auxiliary Connections

The size and location of all auxiliary connections for sealing, circulation, balance and leakage liquid are shown in the general arrangement drawing or piping diagram.

	<p style="background-color: #e67e22; color: white; padding: 5px;">⚠ DANGER</p> <p>Risk of potentially explosive atmosphere by incompatible fluids mixing in the auxiliary piping Risk of burns! Explosion hazard!</p> <ul style="list-style-type: none"> ▷ Make sure that the barrier fluid, quench liquid and/or cooling liquid and fluid handled are compatible.
	<p style="background-color: #d35400; color: white; padding: 5px;">⚠ WARNING</p> <p>Failure to use or incorrect use of auxiliary connections (e.g. barrier fluid, flushing liquid, etc.) Risk of injury from escaping fluid! Risk of burns! Malfunction of the pump!</p> <ul style="list-style-type: none"> ▷ Refer to the general arrangement drawing, the piping layout and pump markings (if any) for the quantity, dimensions and locations of auxiliary connections. ▷ Use the auxiliary connections provided.

3.7 Vacuum Balance Line

If the pump has to pump liquid out of a vessel under vacuum it is advisable to fit a vacuum balance line. This line should have a minimum N.B. of 25 mm and should be arranged to lead back into the vacuum vessel at a point above the highest permissible liquid level.

An additional line from the pump discharge nozzle facilitates pump venting prior to start-up.

- A Main shut-off valve
- B Vacuum balance line
- C Shut-off valve
- E Vacuum-tight shut off valve
- R Non-return flap valve
- V Vacuum vessel
- Z Intermediate flange

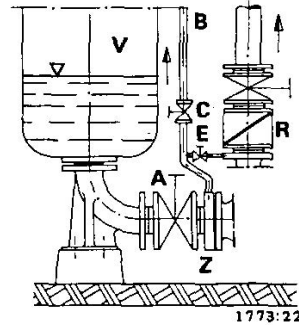

Fig. 6 Suction line and vacuum balance line

3.8 Minimum Flow

If it is possible that the pump will have to operate against a closed discharge valve, a manual or continuous bypass or a bypass check valve must be provided.

3.9 Coupling Guard

Safety regulations specify that the pump must be fitted with a coupling guard. If the purchaser specifically states that he does not want us to supply guard, this must be provided by the operator.

	<p>⚠ WARNING</p>
	<p>Unprotected rotating coupling Risk of injury by rotating shafts!</p> <ul style="list-style-type: none"> ▸ Always operate the pump set with a coupling guard. If the customer specifically requests not to include a coupling guard in KSB's delivery, then the operator must supply one! ▸ Observe all relevant regulations for selecting a coupling guard.
	<p>⚠ DANGER</p>
	<p>Risk of ignition by frictional sparks Explosion hazard!!</p> <ul style="list-style-type: none"> ▸ Choose a coupling guard material that is non-sparking in the event of mechanical contact.

3.10 Final Check

Re-check alignment as described in 3.4. It must be possible to rotate the coupling easily by hand. Check the integrity of all connections.

4. Start-up/Commissioning, Shutdown

4.1 Preparations

4.1.1 Lubricant

The grease-lubricated bearings have already been packed with grease.

4.1.2 Shaft Seal



Check seal (6.4.2)

- Single cartridge seal
- Elastomer bellows
- Independent of direction of rotation
- Stationery seat, rotating spring
- Bellows and spring free from torsion

4.1.3 Priming the Pump and associated Checks

The shutoff valve in the suction line must be fully open.

Fully open all auxiliary connections (flushing, sealing and cooling fluids). Check the flow. Open the shut-off valve in the vacuum line (if fitted) and close the vacuum-tight shut-off valve "E" (Fig 6)

	<div style="background-color: #e67e22; color: white; padding: 5px;">⚠ DANGER</div> <p>Formation of a potentially explosive atmosphere inside the pump Explosion hazard!</p> <ul style="list-style-type: none"> ▸ Before starting up the pump set, vent the pump, mechanical seal housing and suction line, and prime them with the fluid to be handled.
	<div style="background-color: #f1c40f; color: black; padding: 5px;">CAUTION</div> <p>Increased wear due to dry running Damage to the pump set!</p> <ul style="list-style-type: none"> ▸ Never operate the pump set without liquid fill. ▸ Never close the shut-off element in the suction line and/or supply line during pump operation.

4.1.4 Checking the Direction of Rotation





- Align the pump and driver
- Do not connect the coupling between the pump and driver
- Start driver, the direction of rotation must correspond to the arrow on the pump.
- Connect coupling
- Fit coupling guard

4.2 Start-up

Start the set up against a closed discharge valve only. Slowly open the discharge valve to obtain the required duty point after the pump has reached full speed.

N.B.

After the pump has reached its working temperature and/or if the pump leaks, shut the set down and tighten the tie bolts.

	<p>⚠ DANGER</p> <p>Excessive temperatures due to dry running or excessive gas content in the fluid handled Explosion hazard! Damage to the pump set!</p> <ul style="list-style-type: none"> ▷ Never operate the pump set without liquid fill. ▷ Prime the pump as per operating instructions. ▷ Always operate the pump within the permissible operating range.
	<p>⚠ WARNING</p> <p>The suction casing, discharge casing, stage casing, seal housing and seal cover take on the same temperature as the fluid handled. Risk of burns!</p> <ul style="list-style-type: none"> ▷ Do not touch hot components.
	<p>⚠ WARNING</p> <p>The temperature at the bearing bracket can exceed 60 °C during operation. Risk of burns!</p> <ul style="list-style-type: none"> ▷ Do not touch hot components.
	<p>CAUTION</p> <p>Abnormal noises, vibrations, temperatures or leakage Damage to the pump!</p> <ul style="list-style-type: none"> ▷ Switch off the pump (set) immediately. ▷ Eliminate the causes before returning the pump set to service.
	<p>CAUTION</p> <p>Start-up against open discharge line Motor overload!</p> <ul style="list-style-type: none"> ▷ Make sure the motor has sufficient power reserves. ▷ Use a soft starter. ▷ Use speed control.

4.3 Shutdown

Close the discharge valve.

The discharge valve can remain open if the discharge line incorporates a non-return valve, provided there is back pressure.



Switch off the driver, making sure the pump set runs smoothly and evenly down to a standstill.

If the pump set is to remain out of service for long periods, close the shut-off valve in the suction line. Close off the auxiliary connections.

Do not shut off the flow of cooling fluid, if applicable, until the pump has cooled down.

On pumps supplied with product under vacuum, sealing liquid must be supplied to the shaft seal even during stand-still.

If there is a danger of freezing and/or if the pump is to be out of service for long periods, drain the pump or otherwise protect against freezing

	<p style="background-color: #FFD700; margin: 0;">CAUTION</p> <p>Heat build-up inside the pump Damage to the shaft seal!</p> <ul style="list-style-type: none"> ▷ Depending on the type of installation, the pump set requires sufficient after-run time – with the heat source switched off – until the fluid handled has cooled down.
	<p style="background-color: #FFD700; margin: 0;">CAUTION</p> <p>Backflow of fluid handled is not permitted Motor or winding damage! Mechanical seal damage!</p> <ul style="list-style-type: none"> ▷ Close the shut-off elements.

5. Maintenance and Lubrication

5.1 Supervision of operation

The pump must run quietly and evenly at all times.

Avoid dry-running of the pump.

Do not run the pump for a long period against a closed discharge valve.

The bearing temperature may exceed ambient temperature by up to 50°C, but must not exceed 90°C (measured externally on the bearing housing).

The shut-off valves in the auxiliary lines must remain open while the pump is running.

If the pump has a gland packing this should leak slightly during operation. The gland nuts should only be lightly tightened.

If the pump has a mechanical seal this experiences only minor leakage or no visible leakage (flashing) during operation. It is maintenance free.

Any standby pumps should be started up then shut down immediately, at least once a week, to ensure they are in constant readiness for operation. Check the integrity of the auxiliary connections.

The flexible coupling elements should be regularly checked and replaced as soon as they show signs of wear.

5.2 Lubrication and Grease Change

5.2.1 Lubrication



The anti-friction bearings are grease-lubricated.



5.2.2 Grease Change

The initial fill of grease-lubricated anti-friction bearings should be changed after 3000 operating hours or 2 years, whichever is the sooner.

Grade:

Use high-quality lithium soap grease, resin and acid-free not liable to crumble, with good rust preventative properties. It must have a penetration number between 2 and 3, corresponding to a worked penetration between 220 and 295 mm/10. Its drop point must be above 175°C.

	<p>⚠ WARNING</p> <p>Unintentional starting of the pump set Risk of injury by moving components and shock currents!</p> <ul style="list-style-type: none"> ▷ Ensure that the pump set cannot be started unintentionally. ▷ Always make sure the electrical connections are disconnected before carrying out work on the pump set.
	<p>⚠ WARNING</p> <p>Fluids handled, consumables and supplies which are hot and/or pose a health hazard Risk of injury!</p> <ul style="list-style-type: none"> ▷ Observe all relevant laws. ▷ When draining the fluid take appropriate measures to protect persons and the environment. ▷ Decontaminate pumps which handle fluids posing a health hazard.

	 WARNING
	<p>Insufficient stability Risk of crushing hands and feet!</p> <ul style="list-style-type: none">▷ During assembly/dismantling, secure the pump (set)/pump parts to prevent tilting or tipping over.

6. Dismantling and Reassembly

6.1 General

N.B.

Before dismantling, make sure the pump is disconnected from the power supply and cannot be switched on accidentally.

The suction and discharge shut off valves must be closed.

The pump casing must have cooled down to ambient temperature.

The pump casing must be empty and not under pressure.

6.2 Dismantling

1. Detach all auxiliary supply lines.
2. Remove coupling guard.
3. Disconnect pump from driver and detach from baseplate.
4. Unscrew the socket head cap screw in the coupling hub and detach half coupling from the shaft using a pull-off device. Remove key (940.1).
If the pump has been in operation for some time it may be difficult to remove certain parts from the shaft.
If this is the case use a brand name penetrating oil or suitable pull-off device – Never use force!
5. Number and match-mark the stage casing 108 consecutively so that suction casing 108 and the discharge casing 107 will be re-assembled in the correct sequence and position.
6. Support the stage casings 108 so that they do not collapse when the bearing housing (350) is removed (see Fig. 7).
7. Dismantle the pump from the discharge end in the sequence shown in the exploded view on page 29 and 30.
8. Remove all stages up to and including the last impeller.

6.2.1 Mechanical Seal

Pull the mechanical seal (433) off the shaft by hand.

Before assembly, clean the shaft sleeve (523), touch up any grooves or scratched with a polishing cloth. If the score marks still remain visible, you must fit a new shaft sleeve.

Clean the stationery seal ring seat in the seal cover (471).

6.3 Bearings

Suction side (floating bearing):

Pump Size	Cylinder roller bearing DIN 5412 (KSB SA IM nr's)	Adapter Sleeve Din 5415 (KSB SA IM nr's)
32	01022902	00300664
40	01022902	00300664
50	01022903	00300665
65	01022903	00300665
80	01022904	00300666
100	01022905	00300667
125	01050801	01081577
150	01022909	00300670

Discharge side (fixed bearing):

Pump Size	Angular contact ball bearing DIN 628 (KSB SA IM nr's)
32	00300170
40	00300170
50	00300347 ¹⁾
65	00300347 ¹⁾
80	00300348
100	00300356
125	00300351
150	00300353

1) 00300347 or duties up to 300m
for duties over 300m bearing size on request

Before topping up remove old grease.
Lubricant quantity approx. 10gr to 20gr per bearing

6.4 Assembly

6.4.1 Pump

Follow standard engineering practice when assembling the pump.

Coat the fits of the various components and the screw connections with graphite or similar before assembly.

Check O-rings and radial shaft seal rings for damage.

Fit new gaskets throughout, ensuring that they are the same thickness as the old ones.

Reassemble in the reverse order to dismantling. It is essential that the components are fitted in the correct sequence.

If new parts are fitted, realign the first stage impeller axially in relation to the diffuser.

After mounting the first stage diffuser 171.1, align the shaft and impeller so that the centre of the impeller (outlet) corresponds to the centre of the diffuser (inlet) (see Fig. 7).

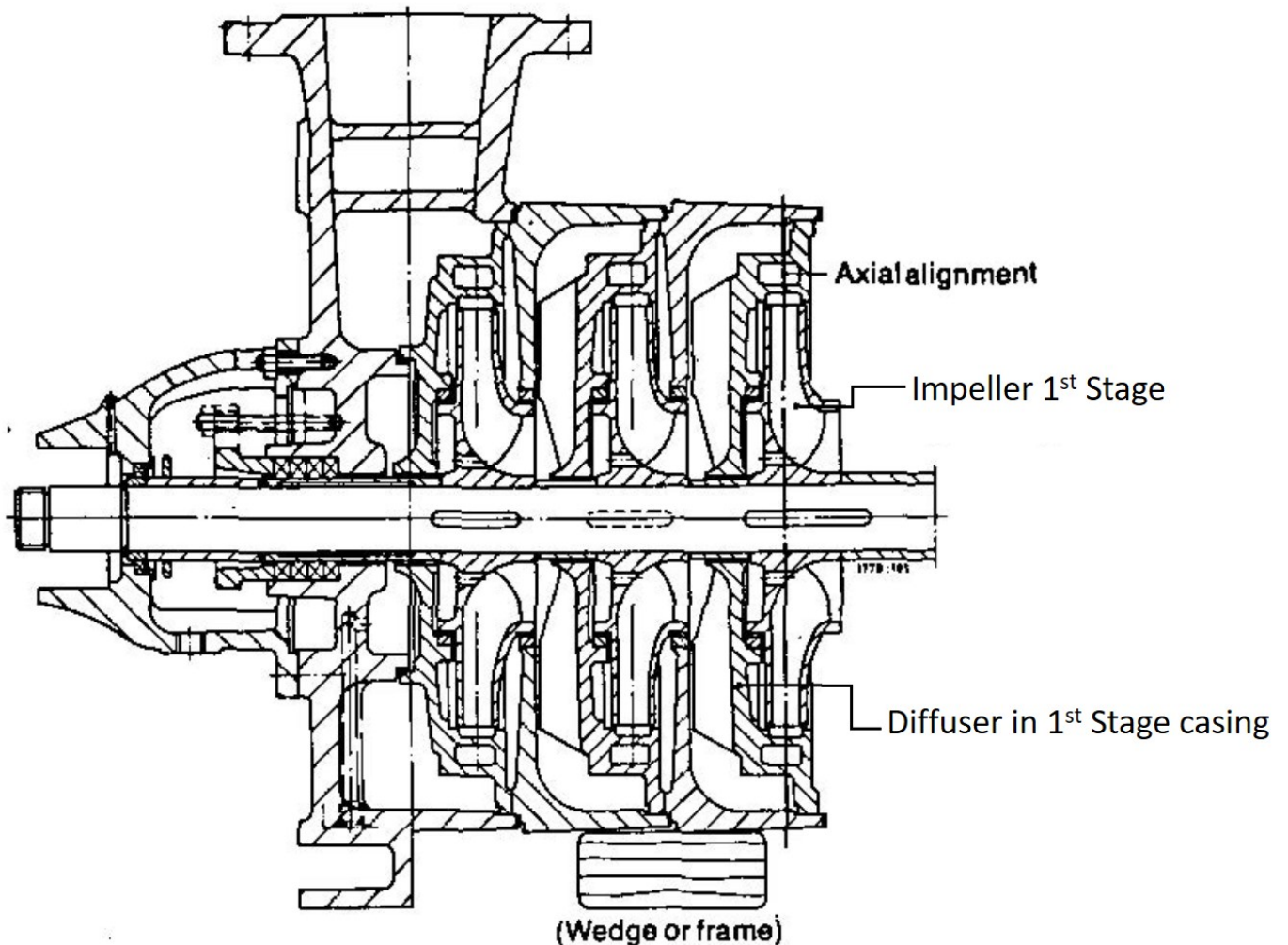

Fig. 7 Axial alignment of rotor

Then make a groove (see Fig. 8) on the shaft in line with the outer edge of the bearing housing 350.1

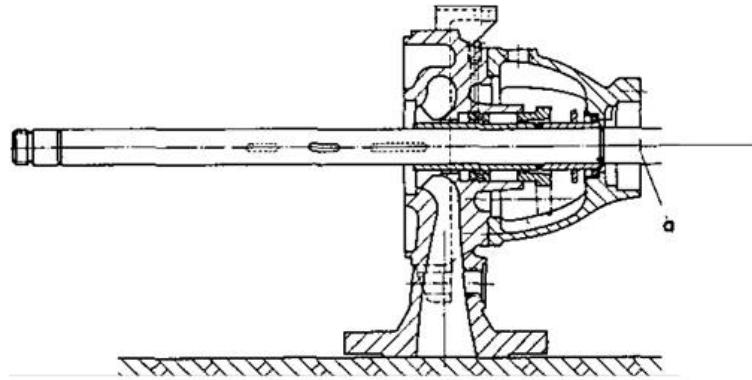

Fig. 8

a = reference groove

With the ball bearing 320 in position, the reference groove must be in its original position.

Fit a spacer ring 504 (spacer ring width = $y - x$, Fig 9)

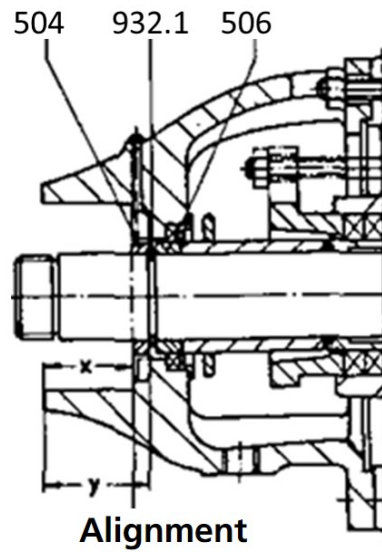

Fig. 9 Correctly sized spacer ring

It must be possible to easily rotate the shaft by hand.

6.4.2 Shaft Seal

6.4.2.1 Packed Gland

Thoroughly clean the box and shaft protecting sleeve before packing the gland.



Fig.10 Packing ring cut to size

Insert the first packing ring and push home using the gland cover.

Fit each subsequent ring separately with its joint offset by 90° to the preceding one using the gland cover.

Tighten the gland nuts lightly and evenly.
It must be possible to rotate the rotor without difficulty.

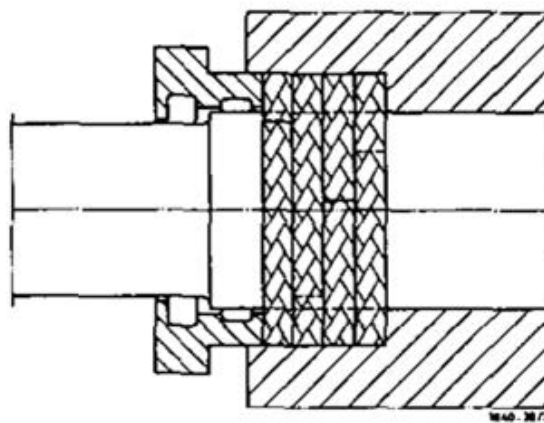

Fig.11 Packing rings, with their joints offset by 90° to the preceding ring.

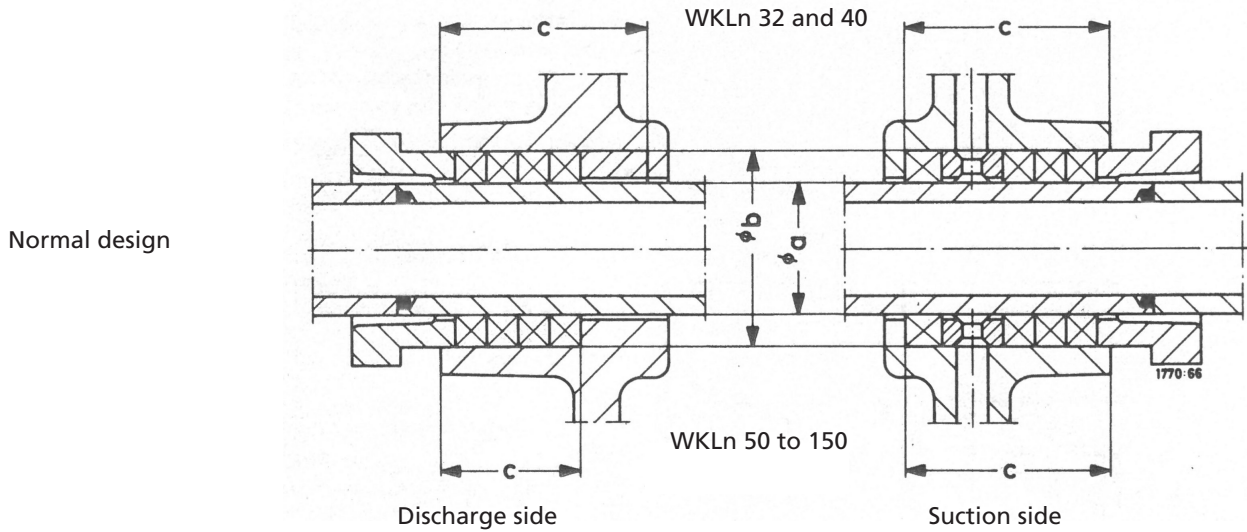
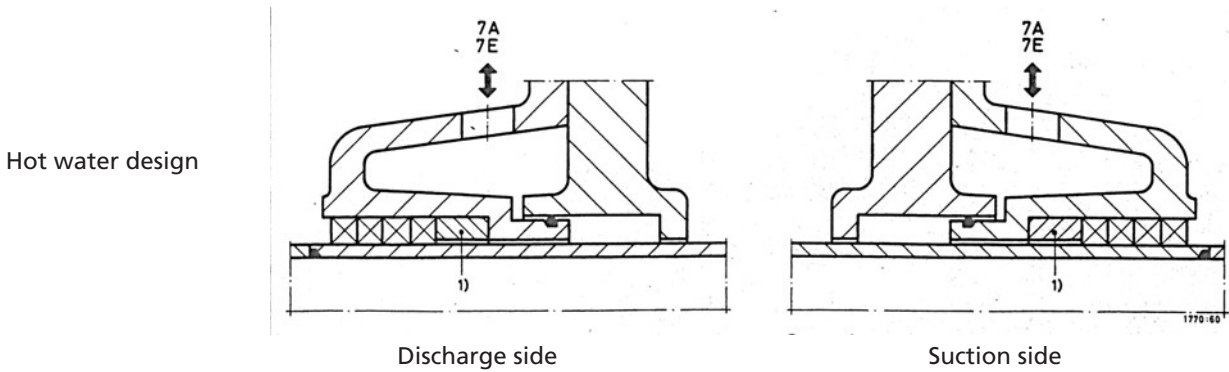

Fig.12 Packing compartment



Dimensions (mm)

	Pump Sizes	32 and 40	50 and 65	80	100	125	150	
Stuffing box (a/b Ø x c)	Suction side							
	Design	N						
		HW	39/55 Ø x 52	45/60 Ø x 63	50/70 Ø x 65	60/85 Ø x 78	66/90 Ø x 78	78/110 Ø x 100
				45/60 Ø x 43	50/70 Ø x 45	60/85 Ø x 53	66/90 Ø x 53	78/110 Ø x 68
Number of rings	Discharge side							
	Design	N / HW	39/55 Ø x 52	45/60 Ø x 43	50/70 Ø x 45	60/85 Ø x 53	66/90 Ø x 53	78/110 Ø x 68
	Suction side							
	Design	N	4 packing rings, 1 lantern ring					
	HW	1 spacer ring	4 packing rings					
Reg. no. of packing per slide	Discharge side							
	Design	N	4 packing rings					
		HW	1 spacer ring	4 packing rings				
		N / HW	8 □ x = 600	10 □ x = 700	10 □ x = 760	12 □ x = 920	12 □ x = 1000	16 □ x = 1200

N = Normal design
HW = Hot water design

6.4.2.2 Mechanical Seal

Reassemble in the reverse order to dismantle.

When fitting a mechanical seal, bear the following points in mind:

Maximum care and maximum cleanliness are mandatory.

Do not remove the guard on the seal faces until just before fitting.

The seal faces and O-rings must not be damaged.

Clean or carefully remove any deposits from the shaft and stationary seal ring seat in the bearing housing.

The shaft sleeve (523) may be oiled to reduce friction when mounting the seal.

N.B.

Epoxy rubber O-rings must not come into contact with oil or grease. Use water.

Push the stationary seal ring into the seal plate with hand or finger pressure, applying pressure evenly to all sides.

When fitting double Teflon-sheathed O-rings, ensure that the ridge of the sheath faces away from the direction of insertion

Fig.13 Teflon-sheathed O-ring

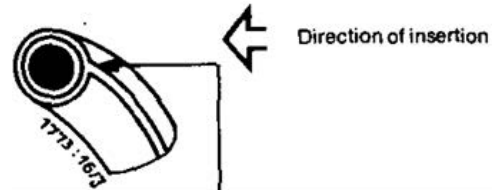

Sheath ridge

6.4.3 Setting Torques for the Tie bolts

Pump size	32	40	50	65	80	100	125	150
Torque Nm	200	200	300	300*	200	250	300	350

* For discharge pressure

Above 1500 KPa

Torque = 350 Nm.

6.5 Cooling Liquid (HW Design)

The minimum permissible cooling liquid flow rates - with a cooling outlet temperature of 40°C - are as follows:

Pump size	32	40	50	65	80	100	125	150
Cooling liquid l/min. approx.	1,5	1,5	2,1	2,1	2,5	2,5	2,8	2,8

Max. coolant outlet temperature 60°C

Max. coolant pressure 6 bar

6.6 External Source Sealing Liquid (Vacuum Operation)

Flow rate of external source liquid (vacuum operation only)

approx. 1 l/min, sealing liquid pressure: 0,5 bar + suction pressure (pz) at least 0,1 bar above atmospheric. The sealant must be compatible with the product pumped.

6.7 Spare Parts

Always give the following information when ordering spare parts:

Type: WKLn Pump size/number of stages (e.g. 80/5)

Product No.:

No.:

This information is to be found on the nameplate.

6.7.1 Recommended List of Spare Parts for 2 years' continuous Operation to VDMA 24 296

Part No.	Part designation	Number of pumps (including stanby pumps)							
		2	3	4	5	6 & 7	8 & 9	10 & over	
		Quantity of spare parts							
210	Shaft with nut with two flats 920.4, circlips 932.1/.2 and Keys 940.1/.3/4.5/.6	1	1	2	2	2	3	30%	
230	Impeller (set = S)	1	1	1	2	2	3	30%	
320	Angular contact ball bearing	1	1	2	2	3	4	50%	
322	Cylindrical roller bearing with clamping sleeve 531	1	1	2	2	3	4	50%	
400.2	Gasket (only on cooled packing)	4	8	8	8	12	12	160%	
412.1/.2	O-ting (set)	4	6	8	8	9	12	150%	
412.3	O-ring (only cooled packing)	4	8	8	8	12	12	160%	
412.4	O-ring (set = S)	4	6	8	8	9	12	150%	
461	Gland packing	4	4	6	6	6	8	40%	
502 ¹⁾	Casing wear ring (set = S x 2)	2	2	2	3	3	4	50%	
521	Stage sleeve (set = S - 1)	2	2	2	3	3	4	50%	
524.1/.2	Shaft protecting sleeve (set = suction and discharge sides)	2	2	2	3	3	4	50%	
525.1/.2	Spacer sleeve (set = suction and discharge sides)	2	2	2	3	3	4	50%	
525.3	Spacer sleeve (only on size 150 non cooled packing Suction side and size 100 - 150 cooled packing)	2	2	2	3	3	4	50%	
525.4	Spacer sleeve (only on sizes 100 and 150 cooled packing) Discharge side	2	2	2	3	3	4	50%	
On Pumps with mechanical seal									
400.5	Gasket	replace part nos. 458, 461, 524.1.2	4	8	8	8	12	12	160%
433	Complete mechanical seal		2	3	4	5	6	7	90%
523.1/.2	Shaft sleeves (set)		2	2	2	3	3	4	50%
S = number of stages									
¹⁾ Size 50 and 65 (set = S x 1) not fitted size 32 and 40									

6.7.2 Alternatively keeping a complete Rotor in stock comprising:

Part No.	Part designation
210	1 Shaft with nut with 2 flats 920.4, circlips 932.1/.2 and keys 940.1/.3/4.5/.6
230	1 set of impellers
412	1 set of O-rings
521	1 set of stage sleeves
524	1 set of shaft protecting sleeves or if the pump has a mechanical seal 523.1 set of sleeves
525	1 set of spacer sleeves

6.8 Exploded Views and List of components

Design with uncooled packed gland

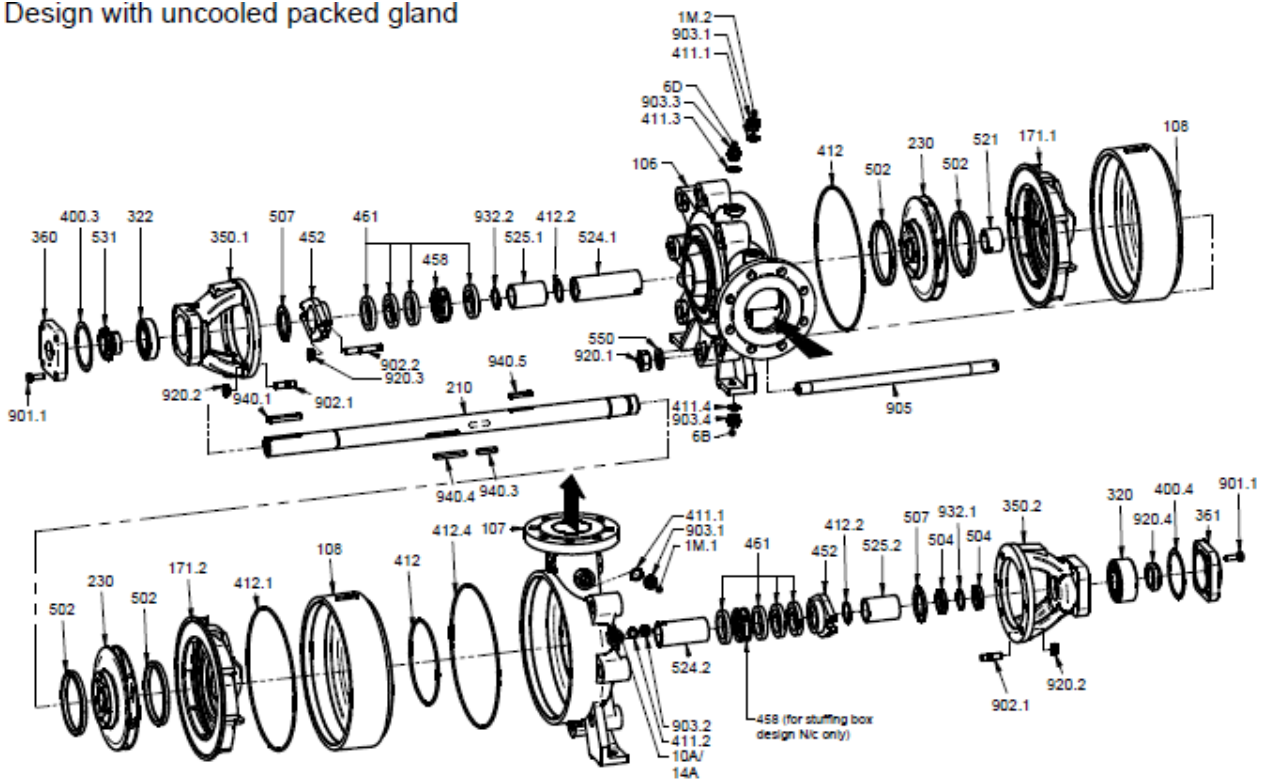

Design with cooled packed gland

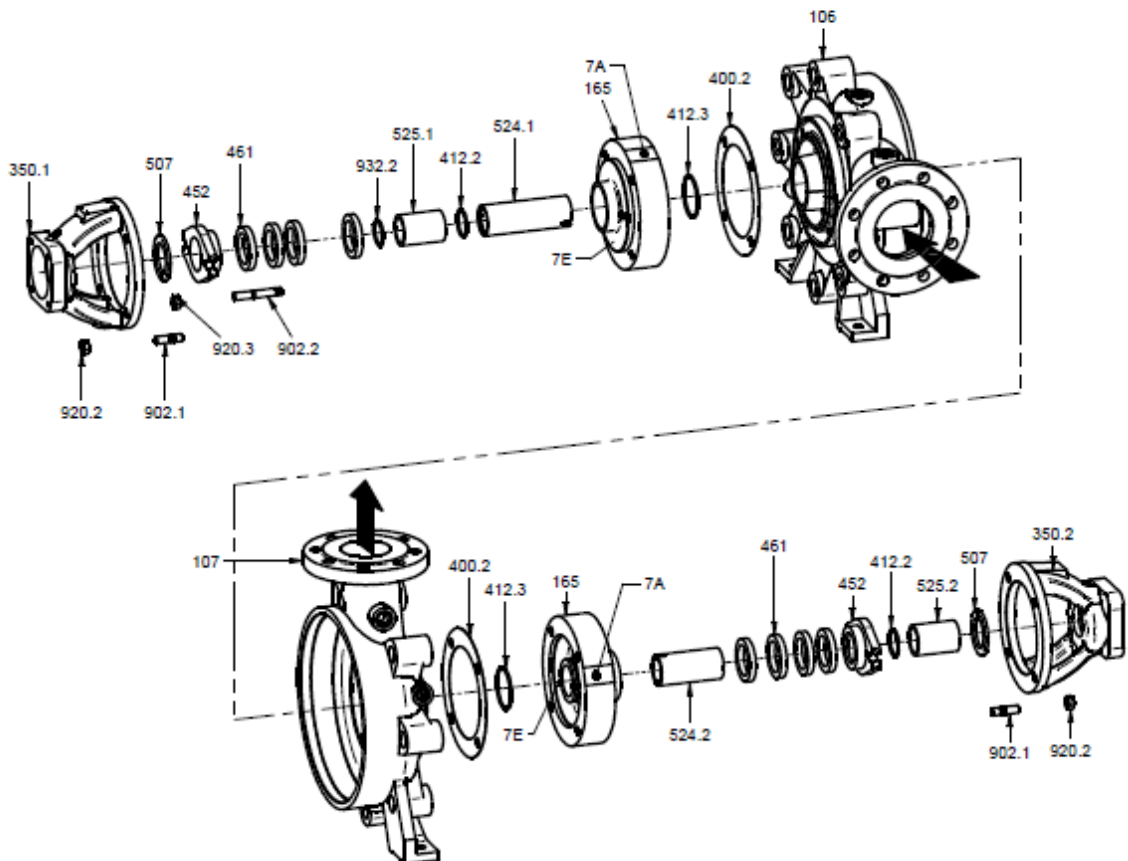

Design with uncooled mechanical seal

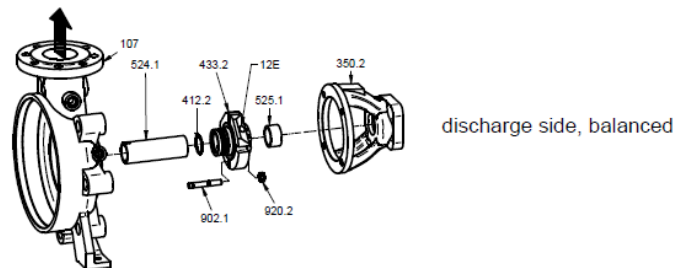
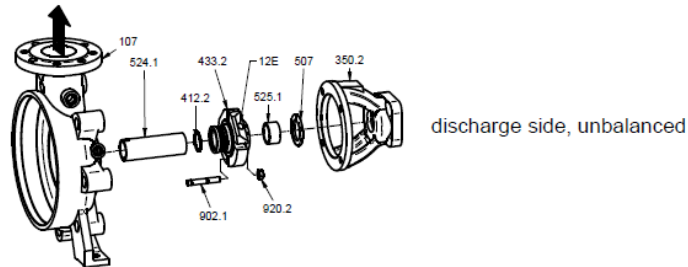
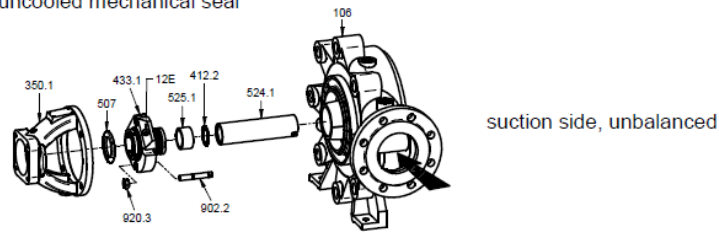

Part No.	Part Designation	Part No.	Part Designation	Part No.	Part Designation
106	Suction casing	507	Thrower	932.1/2	Circlip
107	Discharge casing	521	Stage sleeve	940.1	Key
108	Stage casing	524.1/2	Shaft protecting sleeve	940.2	Key ^{1) 2)}
165	Cooling cover	525.1	Spacer sleeve	940.3/4/5	Key (.5 not fitted on sizes 125 and 150)
171.1	Diffuser	525.2	Spacer sleeve (sizes 100 and 125 N and HW, sizes 80 - 150 mechanical seal)	1M.1/2	Connection for pressure measing instrument
171.2	Last stage diffuser	525.3 ¹⁾	Spacer sleeve (size 105 N and mechanical seal, sizes 100 - 150 HW)	6B	Product drain
210	Shaft	525.4 ¹⁾	Spacer sleeve (sizes 100 and 150 HW)	6D	Product prime vent
230	Impeller	531	Clamping sleeve	7A	Cooling liquid outlet
320	Angular contact ball bearing	550	Disc	7E	Cooling liquid inlet
322	Cylindrical roller bearing	562 ¹⁾	Cylindrical pin	8B ¹⁾	Leakage drain
350.1/2	Bearing housing	636 ¹⁾	Grease nipple	9A ¹⁾	Sealing liquid outlet
360	Bearing cover	901.1	Hex. head bolt	9E ¹⁾	Sealing liquid inlet
361	Bearing end cover	902.1/2/3	Stud (.3 sizes 100 - 150 mechanical seal)	12E	Circulation liquid inlet
400.2/4	Gasket	903.1/2/3/4	Threaded plug		
411.1/2/3/4	Gasket	905	Tie bolt		
412.1/2/3/4	O-ring	914	Socket head screw (size 80 mechanical seal)		
433.1/2	Mechanical seal	920.1/2/3	Hex. nut	¹⁾	not illustrated
452	Gland cover	920.4	Nut with two flats	²⁾	applies only to pumps with drive from either end
458	Lantern ring			³⁾	1 fitted on size 50 and 65 2 on sizes 80 to 150
461	Gland packing				
502 ³⁾	Casing wear ring				
504	Spacer ring				

6.9 Faults

Fault	Code number Cause - Remedy
Pump delivers insufficient liquid	1, 2, 3, 4, 5, 6, 8, 9, 10, 11, 28
Driver is overloaded	12, 13, 15, 28
Excessively high pump discharge pressure	15
Excessively high bearing temperature	22, 23, 24, 25, 26
Leakage at the pump	16
Excessive leakage at shaft seal	17, 18, 21, 22, 23, 33
The pump runs rough	3, 6, 11, 12, 22, 23, 25, 30, 31, 32
Excessive temperature rise inside the pump	3, 6, 32
Numbers omitted do not apply to this type series	

Cause - Remedy¹⁾

1. The pump generates an excessively high differential pressure
 - Reset the duty point
2. Excessively high back pressure
 - Check the pump set for impurities
 - Fit larger impeller(s) ²⁾
 - Increase speed (applies to turbine driven or I.C. engine driven pumps)
3. The pump and/or piping are incompletely vented or primed
 - Vent or prime the pump and piping completely
4. Suction line or impeller(s) clogged
 - Remove deposits in the pump and/or piping
5. Formation of air pockets in the piping
 - Alter piping layout
 - If necessary, fit a vent valve
6. Suction head too great/NPSH available too small
 - Check liquid level in suction vessel
 - Open isolating valve in suction line fully
 - After suction line if necessary, if the friction losses in the suction line are excessive
 - Check suction line strainers/suction aperture
8. Ingress of air through the stuffing box
 - Sealing liquid passage is clogged; clean it out if necessary, arrange a sealing liquid supply from an outside source, or increase sealing liquid pressure
 - Fit a new shaft seal
9. Reverse rotation
 - Change over two phases of the power supply cable
10. Rotational speed is too low
 - ²⁾
 - Increase speed
11. Excessive wear of the pump internals
 - Replace worn components with new ones
12. Pump back pressure is lower than specified in the purchase order
 - Accurately set the duty point
 - In case of persistent overloading, trim the impeller(s) if necessary
 - ²⁾
13. Specific gravity or viscosity of the fluid pumped is higher than specified in the purchase order
 - ²⁾
15. Excessive rotational speed
 - Reduce speed
 - ²⁾
16. Tie bolts/ O-rings
 - Tighten up the bolts
 - Fit new O-rings
17. Worn shaft seal
 - Check condition of shaft seal and renew it if necessary
 - Check flushing liquid or sealing liquid pressure
18. Grooving, score marks or roughness on shaft protecting sleeve/shaft sleeve surface
 - Fit new shaft protecting sleeve/shaft sleeve
 - Fit new shaft seal

Fault	Code number Cause - Remedy
Pump delivers insufficient liquid	1, 2, 3, 4, 5, 6, 8, 9, 10, 11, 28
Driver is overloaded	12, 13, 15, 28
Excessively high pump discharge pressure	15
Excessively high bearing temperature	22, 23, 24, 25, 26
Leakage at the pump	16
Excessive leakage at shaft seal	17, 18, 21, 22, 23, 33
The pump runs rough	3, 6, 11, 12, 22, 23, 25, 30, 31, 32
Excessive temperature rise inside the pump	3, 6, 32
Numbers omitted do not apply to this type series	

Cause - Remedy¹⁾

21. The pump runs noisily
 - Correct the suction conditions
 - Check alignment of pump set and realign if necessary
 - Re-balance the pump rotor
 - Increase the suction pressure at pump suction nozzle
22. Pump set misaligned
 - Check alignment at coupling and realign the set if necessary
23. The pump is warped or resonance vibrations in the piping
 - Check the piping connections and pump fixing bolts, if necessary reduce the distance between the pipe clamps
 - support the piping using vibration absorbing material
24. Excessive axial thrust
 - ²⁾
 - Clean out balance holes in impeller
25. Too much, little or unsuitable lubricant quality
 - Reduce quantity of or top up. lubricant or change lubricant quality
26. The specified coupling gap has not been maintained
 - Restore correct coupling gap in accordance with the data on the installation plan
28. The motor is running on two phases only
 - Replace the defective fuse
 - Check electrical connections
30. The rotor is out of balance
 - Re-balance the rotor dynamically
31. Defective bearings
 - Fit new bearings
32. Insufficient rate of flow
 - Increase the minimum rate of flow
33. Faults in the circulation liquid supply
 - Increase the cross-section of the circulation liquid line

¹⁾The pump should be vented before attempting to remedy faults in parts under pressure

²⁾Please refer to KSB



KSB Pumps and Valves (Pty) Ltd

Cnr North Reef and Activia Roads, Activia Park, Germiston

Tel. + 11 876 5600

info-za@ksb.com

www.ksb.com/ksb-za