

Introduction

Motors controlled by VFDs or servo drives require additional attention to avoid overvoltage spikes, known as dV/dt . Voltage wave reflection is a function of the voltage rise time (dV/dt) and the length of the motor cables. This phenomenon creates additional overvoltage spikes which cause premature degradation and failure to the motor insulation.

The challenge for OEMs, system integrators and distributors is to ensure that the installed motors are well protected from overvoltage. Markets using VFDs have adopted a special motor, better known as, a motor rated VFD or inverter duty motor.

The motor rated VFD construction can change significantly based on the manufacturer. However following the National Electrical Manufacturer's Association (NEMA), the greatest difference between a standard motor and an inverter duty motor is the winding insulation.

For example, a nominal 480 Vac AC drive using a standard grade motor should maintain performance and function with peak voltage up to 1000V. For inverter duty rated motors the acceptable peak voltage is typically 1500V.

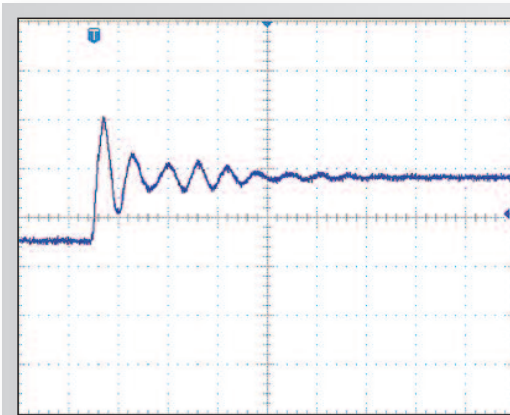

Typical example of dV/dt measured on the motor with cable length of 50m (150 ft)

Theory

To better understand what causes motor failure and unforeseen challenges, it is best to first understand how a VFD is assembled. VFDs are made up of three major parts:

- The rectifier - takes incoming AC power and converts it to DC power
- The DC link - several capacitors used for energy storage from the output of the rectifier
- The inverter - produces 2-20 kHz signal used to generate the output waveform to the motor using pulse width modulation (PWM)

PWM is a technique which generates the width of a pulse based on modulation signal information. Due to this technique, the dV/dt presents a significant concern.

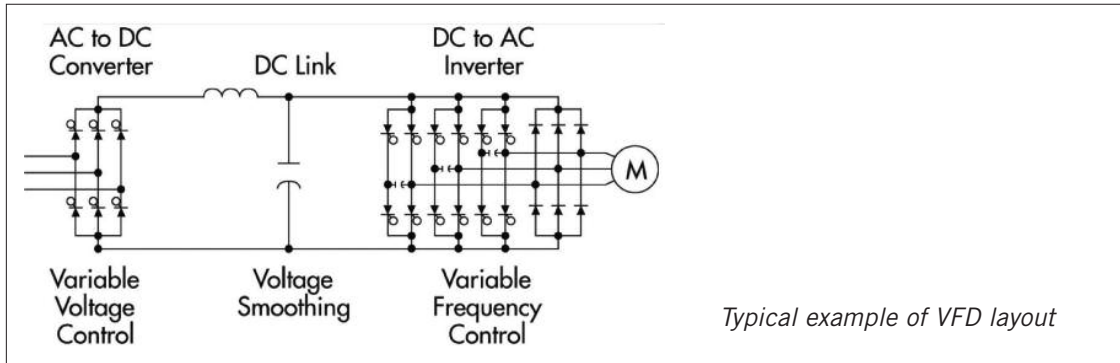

The Solution

Enerdoor has developed the motor protection series to protect motors from harmful overvoltage and dV/dt spikes generated by the drive's output.

This is particularly useful for applications with variable frequency drives and servo drives. Enerdoor solutions include: common mode and differential mode chokes, sine wave filters and snubbers; all of which are designed to work with various carrier frequencies, output frequencies and applications.

Specific Solutions

Sine Wave Filters: This series reduces the effect of the PWM by converting the drive's output to a true sine waveform, eliminating dV/dt .

The **FIN915SF** model is used with fundamental frequencies up to 25kHz.

The high frequency inductance **FIN960F** is a unique solution used for synchronous motor spindle applications with output frequencies ranging from 1 Hz to 10 kHz.

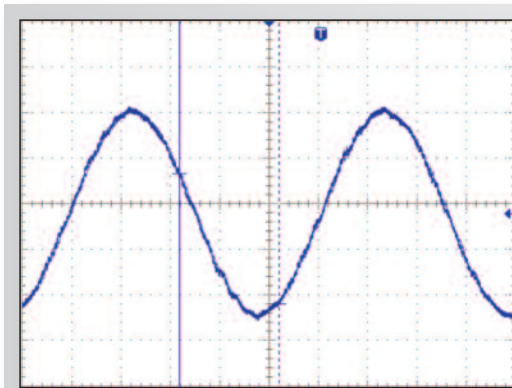

Typical example of a waveform between the VFD and motor using an Enerdoor sine wave filter FIN915SFH



Snubber: Enerdoor snubber **FIN47SNB** is a unique solution to reduce common mode and differential mode noise. The snubber is used in parallel to the system and is an ideal solution for clients in need of improving the reliability of winding insulation and bearings.

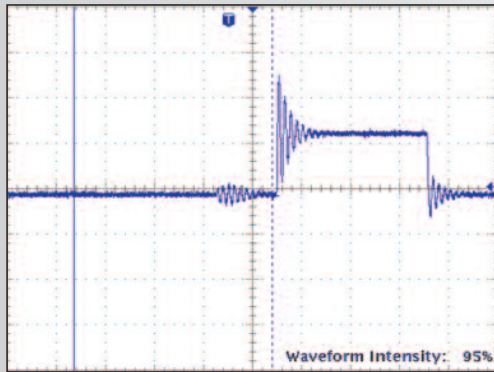

Typical measurement of dV/dt on the motor side of VFD with cable length of 100m (300ft)

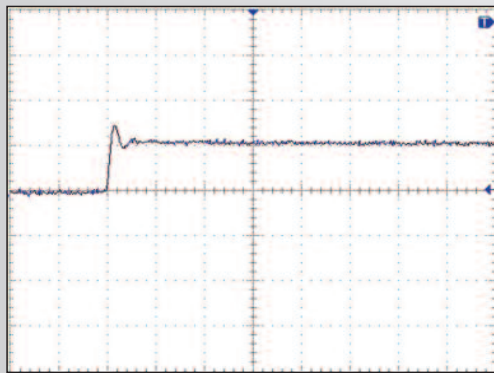

Typical measurement of dV/dt on the motor side of VFD with cable length of 100m (300ft) with Enerdoor snubber FIN47SNB installed



Filter Selection Guide	Description	Current Range (A)	Voltage	CONNECTORS				FEATURES					APPLICATIONS					Approval
				Cables	Terminal Blocks	Screws	Bus Bar	Common Mode Attenuation	Differential Mode Attenuation	Very Long Cable Applications	Output Frequency >75Hz	Compact Case	Long Cable Application >300m	CNC Machine	High Frequency Spindle Motor	Motor Controlled by VFD <100m	Closed Loop Motor Application	
Motor Protection																		
FIN900	3-phase	10-280	0-600	X	X	X		X					X		X		X	
FIN930	3-phase	6-200	0-600		X			X									X	
FIN950U	3-phase	8-300	0-600		X		X	X									X	
FIN5955	3-phase	3-20	0-600		X			X			X		X		X		X	UL US
FIN5958	3-phase	12-110	0-600		X			X		X	X	X	X	X	X		X	
FIN5980P	3-phase	9-22	0-480	X	X								X					UL US
FIN5983	3-phase	12-60	0-600		X							X	X				X	UL US
FIN960F	3-phase	10-1000	0-750		X			X		X			X	X				
FIN905SF	3-phase	5-880	0-600		X		X	X	X		X							
FIN915SFH	3-phase	5-1100	0-600		X			X	X	X				X				
FIN47SNB	3-phase plus neutral	-	0-600		X				X		X	X				X	X	
FINSTP	star point to ground	-	0-600		X				X	X	X	X				X	X	UL US

Enerdoor motor protection reduces harmful dV/dt generated by variable frequency drives imposed onto the motor. Motor protection devices are designed to work in various applications of switching frequencies and frequency outputs.

This series carries CE and UL approvals and offers a current range from 3 to 1100A. Enerdoor motor protection includes common mode and differential mode inductance, sine wave filters and snubbers.

Unique features include: high linearity vs frequency and current, very low operating temperatures, and compact dimensions.

The FIN960F high frequency inductance is a unique solution used for synchronous spindle motor applications. This line works with frequency output up to 2 kHz while allowing the motor to operate at a low temperature.

The FIN905SF and FIN915SFH sine wave filters reduce the PWM effect, convert the PWM to a sine wave and eliminate dV/dt . These lines work with applications in open or closed loop feedback.

The FIN905SF works with frequency output up to 70 Hz. The FIN915SFH line is used with fundamental frequencies up to 2 kHz while maintaining a very low application temperature.

Motor protection applications include:

- Motors controlled by drives
- Pumps and conveyors
- Automated machinery
- Closed loop motor applications
- High speed motors
- CNC machinery
- Long cable applications
2,500m (8,200 ft)
- Process plants
- Water treatment plants
- Packaging machinery

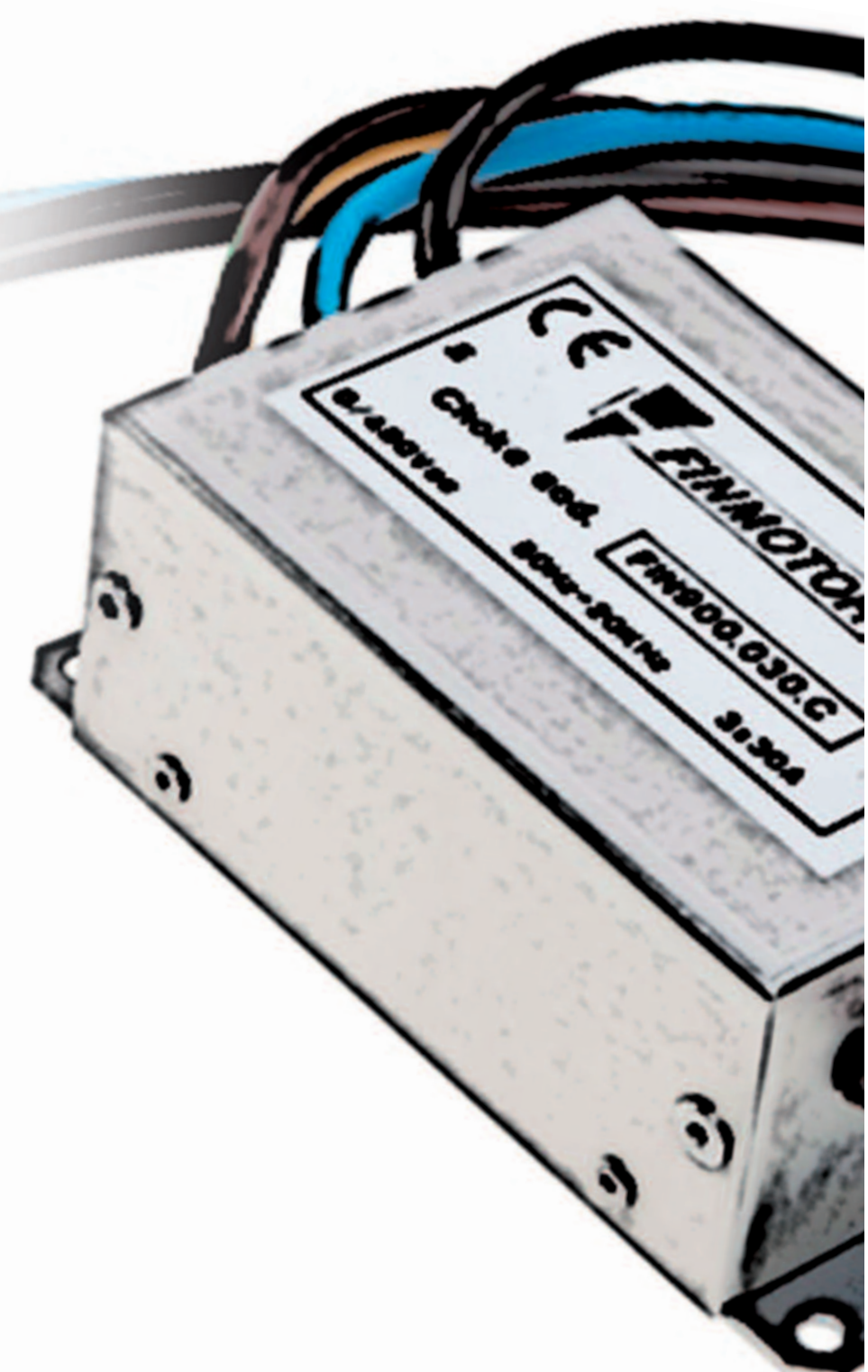



High frequency sine wave filter with excellent attenuation for variable frequency drive applications

Datasheet 3/2019

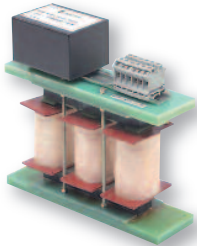
APPROVALS:

FIN915SFH.(005 - 048).M
FEATURES

- Rated current from 5 to 1100A
- High performance sine wave output
- Eliminates dV/dt and increases motor life
- Ideal for high speed motor - 0 Hz to 10 kHz

BENEFITS

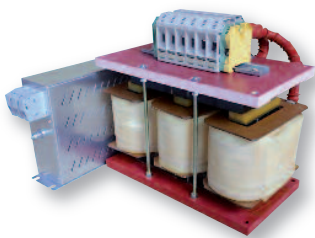
- Terminal blocks up to 880A
- Very compact design
- Available in open frame or enclosure

FIN915SFH.(060 - 360).M
MARKETS

- Long cable applications - 2,500m
- Frequency drives and servo drives >75 Hz
- Process plants
- Water treatment plants
- Agriculture

ORDERING CODE

Model	Current (A)	Connection	Enclosure
FIN915SF	.100	.M	-N1
		M = Terminal	N1 = Nema 1
		V = Screws	N3R = Nema 3R
		BC = Bus bar	

ATTENUATION INDICATOR

High	Very High	Excellent

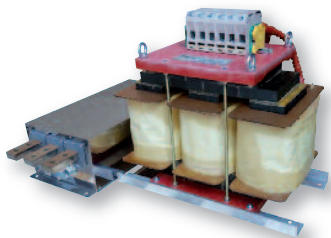
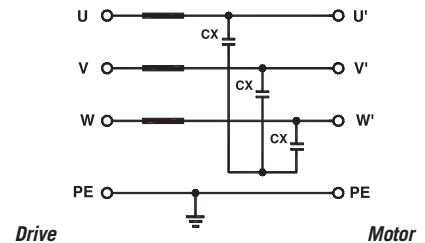
ELECTRIC DIAGRAM

FIN915SFH.(480 - 1100).M
TECHNICAL SPECIFICATIONS

Nominal voltage	0 / 600 Vac
Output frequency	0 Hz - 10 kHz
Rated current	5 to 1100A
Carrier frequency (PWM)	>2 kHz, see table
Ambient temperature	70°C
Altitude	1000 m
Relative humidity	<95% no condensation
Saturation current	4 x Rated Current (Switch ON) 2 x In 10 seconds 1.5 x In 10 minutes 1.5 x Nominal current
IP Protection	IP20 up to 360A IP00 over 480A
Optional	Enclosure, fan, finger safe protection

ELECTRICAL CHARACTERISTICS

FIN915SFH	Rated Current 40°C	Min Switch Freq. (kHz)	Power Loss (W)
.005.M	5	2	50
.010.M	10	2	70
.016.M	16	2	98
.025.M	25	2	105
.036.M	36	2	110
.048.M	48	2	195
.060.M	60	2	220
.075.M	75	2	255
.115.M	115	4	420
.180.M	180	4	602
.210.M	210	4	650
.260.M	260	4	701
.360.M	360	6	800
.480.M	480	6	980
.610.M	610	6	1300
.680.M	680	6	1400
.770.M	770	6	2050
.860.M	860	6	2430
.960.M	960	6	2765
.1100.M	1100	6	2915

CONNECTIONS

LINE			PE
Solid Cable (mm ²)	Stranded Cable (mm ²)	Terminal Block Torque (Nm)	Torque (Nm)
0.2-10	0.2-6	1.2	1.2
0.2-10	0.2-6	1.2	1.2
0.2-10	0.2-6	1.2	1.2
0.2-10	0.2-6	1.2	1.2
0.2-10	0.2-6	1.8	1.8
0.2-10	0.2-6	1.8	1.8
6-35	4-25	4.5	4.5
6-35	4-25	4.5	4
10-50	10-50	4	4
39-95	35-95	20	20
35-150	35-150	20	20
35-150	35-150	20	20
35-150	35-150	20	20
35-150	35-150	20	20
35-150	35-150	20	20
35-150	35-150	20	20
35-150	35-150	20	20
35-150	35-150	20	20
35-150	35-150	20	20
35-150	35-150	20	20
35-150	35-150	20	20

TYPICAL MEASUREMENT

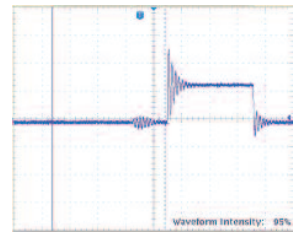

Standard waveform measured when the motor is controlled by VFD drive.

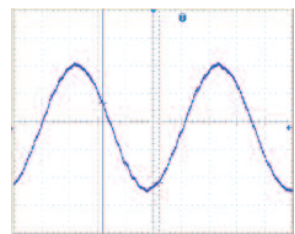

Standard waveform measured when Enerdoor sine wave filter is installed on motor controlled by VFD drive.

MECHANICAL DIMENSIONS mm

FIN915SFH	A	B	C	D	E	F	G	Weight Kg.	Case
.005.M	260	170	252	240	110	8	138	5	1
.010.M	260	170	252	240	110	8	138	6.5	1
.016.M	260	170	252	240	110	8	138	8	1
.025.M	300	240	265	280	140	8	160	12	2
.036.M	300	240	265	280	140	8	160	14	2
.048.M	300	240	265	280	140	8	160	17	2

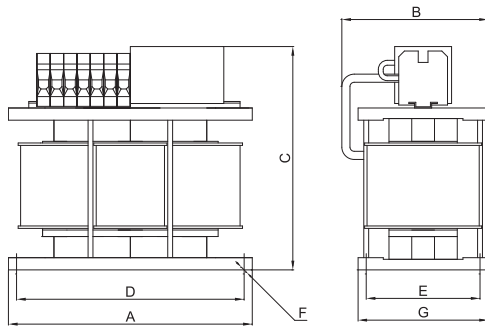
CASE 1, 2

FIN915SFH	A	B	C	D	E	F	G	I	L	N	P	R	dØ	V	Weight Kg.	Case
.060.M	400	250	335	370	170	12	260	293	100	120	135	5	5	180	30	3
.075.M	540	360	460	500	200	12	260	293	100	120	135	5	5	180	38	3
.115.M	540	360	460	500	200	12	260	389	130	205	220	5	5	260	63	4
.140.M	540	360	460	500	200	12	260	389	130	205	220	5	5	260	80	4
.180.M	540	320	465	500	200	12	260	389	130	205	220	5	5	260	83	4
.210.M	540	320	465	500	200	12	260	450	150	280	295	5	5	260	88	5
.260.M	540	320	465	500	200	12	260	450	150	280	295	5	5	260	110	5
.360.M	540	320	465	500	200	12	260	450	150	280	295	5	5	260	150	5

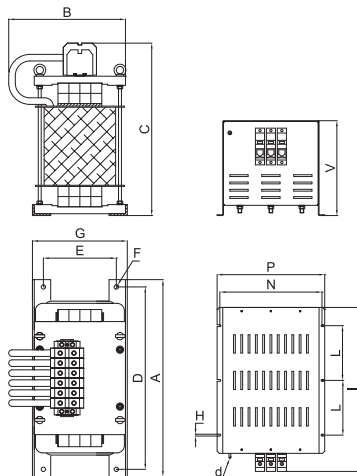
CASE 3, 4, 5

MECHANICAL DIMENSIONS mm

FIN915SFH	A	B	C	D	E	F	G	I	L	N	P	V	H	d	S	Weight Kg.	Case
.480.M	540	340	475	500	200	12	260	620	660	244	295	262	16	M5	25x10	115	6
.610.M	540	340	475	500	200	12	260	620	660	244	295	262	16	M5	25x10	120	6
.680.M	540	340	475	500	200	12	260	830	790	244	292	292	16	M5	25x10	126	7
.770.M	540	340	475	500	200	12	260	830	790	244	292	292	16	M5	25x10	130	7
.860.M	540	340	475	500	200	12	260	885	830	474	520	292	16	M5	40x20	135	8
.960.M	540	340	475	500	200	12	260	885	830	474	520	292	16	M5	40x20	150	8
.1100.M	540	340	475	500	200	12	260	885	830	474	520	292	16	M5	40x20	200	8

CASE 6, 7, 8

