

Introduction

Motors controlled by VFDs or servo drives require additional attention to avoid overvoltage spikes, known as dV/dt . Voltage wave reflection is a function of the voltage rise time (dV/dt) and the length of the motor cables. This phenomenon creates additional overvoltage spikes which cause premature degradation and failure to the motor insulation.

The challenge for OEMs, system integrators and distributors is to ensure that the installed motors are well protected from overvoltage. Markets using VFDs have adopted a special motor, better known as, a motor rated VFD or inverter duty motor.

The motor rated VFD construction can change significantly based on the manufacturer. However following the National Electrical Manufacturer's Association (NEMA), the greatest difference between a standard motor and an inverter duty motor is the winding insulation.

For example, a nominal 480 Vac AC drive using a standard grade motor should maintain performance and function with peak voltage up to 1000V. For inverter duty rated motors the acceptable peak voltage is typically 1500V.

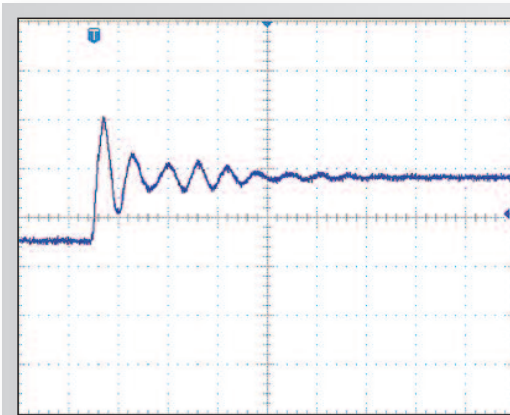

Typical example of dV/dt measured on the motor with cable length of 50m (150 ft)

Theory

To better understand what causes motor failure and unforeseen challenges, it is best to first understand how a VFD is assembled. VFDs are made up of three major parts:

- The rectifier - takes incoming AC power and converts it to DC power
- The DC link - several capacitors used for energy storage from the output of the rectifier
- The inverter - produces 2-20 kHz signal used to generate the output waveform to the motor using pulse width modulation (PWM)

PWM is a technique which generates the width of a pulse based on modulation signal information. Due to this technique, the dV/dt presents a significant concern.

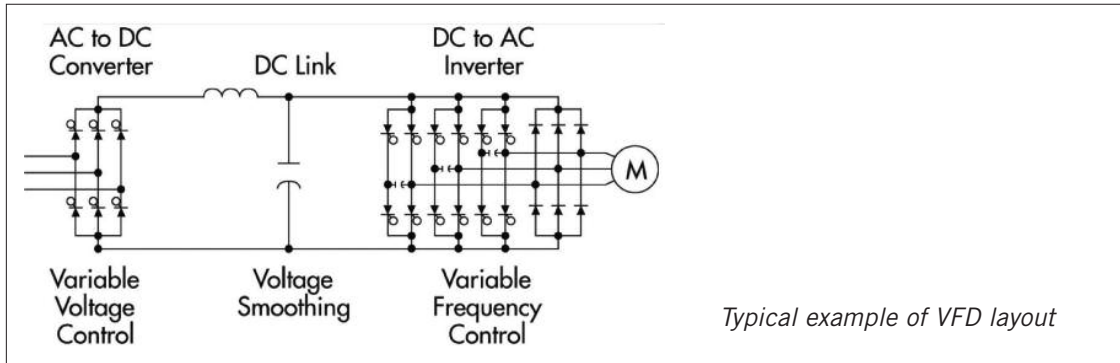

The Solution

Enerdoor has developed the motor protection series to protect motors from harmful overvoltage and dV/dt spikes generated by the drive's output.

This is particularly useful for applications with variable frequency drives and servo drives. Enerdoor solutions include: common mode and differential mode chokes, sine wave filters and snubbers; all of which are designed to work with various carrier frequencies, output frequencies and applications.

Specific Solutions

Sine Wave Filters: This series reduces the effect of the PWM by converting the drive's output to a true sine waveform, eliminating dV/dt .

The **FIN915SF** model is used with fundamental frequencies up to 25kHz.

The high frequency inductance **FIN960F** is a unique solution used for synchronous motor spindle applications with output frequencies ranging from 1 Hz to 10 kHz.

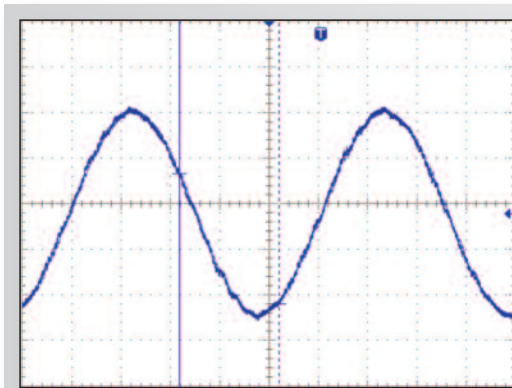

Typical example of a waveform between the VFD and motor using an Enerdoor sine wave filter FIN915SFH



Snubber: Enerdoor snubber **FIN47SNB** is a unique solution to reduce common mode and differential mode noise. The snubber is used in parallel to the system and is an ideal solution for clients in need of improving the reliability of winding insulation and bearings.

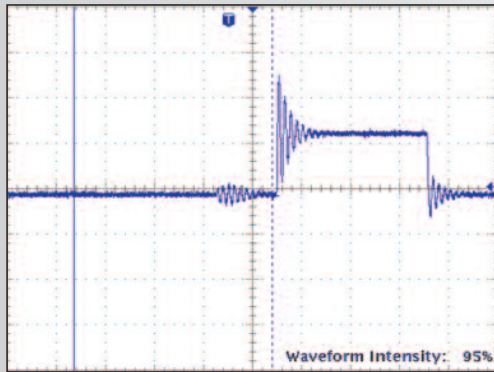

Typical measurement of dV/dt on the motor side of VFD with cable length of 100m (300ft)

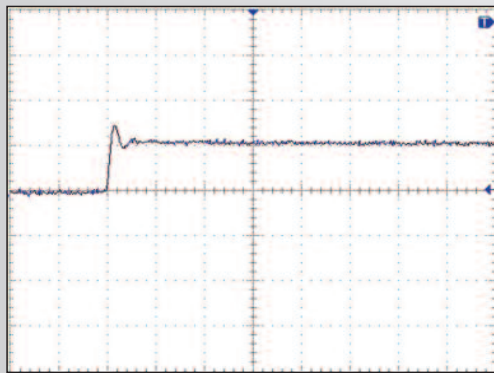

Typical measurement of dV/dt on the motor side of VFD with cable length of 100m (300ft) with Enerdoor snubber FIN47SNB installed



Filter Selection Guide	Description	Current Range (A)	Voltage	CONNECTORS				FEATURES					APPLICATIONS					Approval
				Cables	Terminal Blocks	Screws	Bus Bar	Common Mode Attenuation	Differential Mode Attenuation	Very Long Cable Applications	Output Frequency >75Hz	Compact Case	Long Cable Application >300m	CNC Machine	High Frequency Spindle Motor	Motor Controlled by VFD <100m	Closed Loop Motor Application	
Motor Protection																		
FIN900	3-phase	10-280	0-600	X	X	X		X					X		X		X	
FIN930	3-phase	6-200	0-600		X			X										X
FIN950U	3-phase	8-300	0-600		X		X	X									X	
FIN5955	3-phase	3-20	0-600		X			X				X		X		X		
FIN5958	3-phase	12-110	0-600		X			X		X	X	X	X	X	X		X	
FIN5980P	3-phase	9-22	0-480	X	X								X					
FIN5983	3-phase	12-60	0-600		X							X	X				X	
FIN960F	3-phase	10-1000	0-750		X			X		X			X	X				
FIN905SF	3-phase	5-880	0-600		X		X	X	X			X						
FIN915SFH	3-phase	5-1100	0-600		X			X	X	X					X			
FIN47SNB	3-phase plus neutral	-	0-600		X					X		X	X			X	X	
FINSTP	star point to ground	-	0-600		X					X	X	X	X			X	X	

Enerdoor motor protection reduces harmful dV/dt generated by variable frequency drives imposed onto the motor. Motor protection devices are designed to work in various applications of switching frequencies and frequency outputs.

This series carries CE and UL approvals and offers a current range from 3 to 1100A. Enerdoor motor protection includes common mode and differential mode inductance, sine wave filters and snubbers.

Unique features include: high linearity vs frequency and current, very low operating temperatures, and compact dimensions.

The FIN960F high frequency inductance is a unique solution used for synchronous spindle motor applications. This line works with frequency output up to 2 kHz while allowing the motor to operate at a low temperature.

The FIN905SF and FIN915SFH sine wave filters reduce the PWM effect, convert the PWM to a sine wave and eliminate dV/dt . These lines work with applications in open or closed loop feedback.

The FIN905SF works with frequency output up to 70 Hz. The FIN915SFH line is used with fundamental frequencies up to 2 kHz while maintaining a very low application temperature.

Motor protection applications include:

- Motors controlled by drives
- Pumps and conveyors
- Automated machinery
- Closed loop motor applications
- High speed motors
- CNC machinery
- Long cable applications
2,500m (8,200 ft)
- Process plants
- Water treatment plants
- Packaging machinery

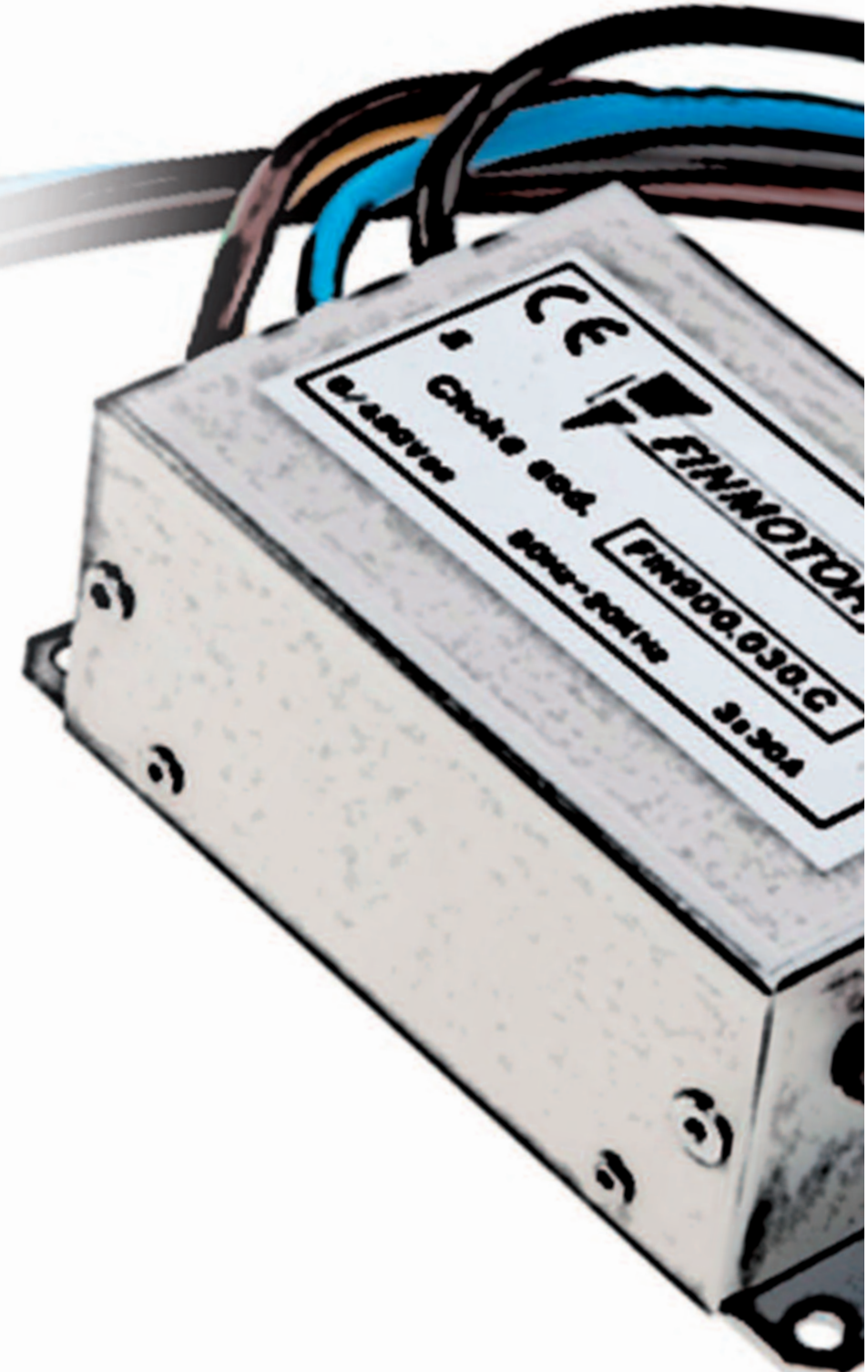



Differential mode choke with very high attenuation to reduce dV/dt

Datasheet 3/2019

APPROVALS:



FIN950U.(008 - 300).M

Models available with current ratings up to 3000A

FEATURES

- Rated current from 8 to 300A
- Increases motor life
- Protects against voltage spikes on the motor

BENEFITS

- Terminal blocks up to 200A
- Low power loss
- Available in open frame or enclosure

MARKETS

- Motors controlled by drives
- Pumps
- Conveyors

ORDERING CODE

FIN 950U .008 .M
 Model Current (A) Connection
 M = Terminal block

ATTENUATION INDICATOR

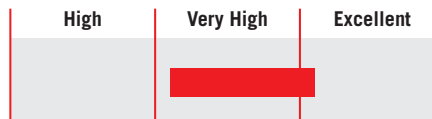

ELECTRIC DIAGRAM

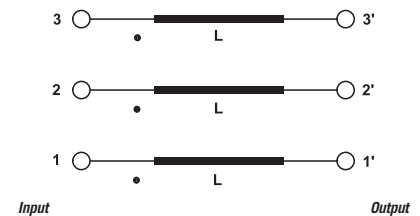

TECHNICAL SPECIFICATIONS

Nominal voltage	0 / 600 Vac *
Output frequency	0 - 100 Hz
Carrier frequency	0 - 16 kHz
Rated current	8 to 300A
Insulation class	H
IP Protection	IP20 up to 200A IP00 over 200A
Saturation current	4 x Rated current (Switch ON) 2 x In 10 seconds 1.5 In for 10 minutes 1.5 x Nominal current
Climatic class	-40 / +85° C
MTBF at 40°C	250.000 Hrs

* Available higher voltages

ELECTRICAL CHARACTERISTICS

FIN950U	Rated Current 40°C	Rated Current 50°C	Power Loss (W)
.008.M20	8	6	23
.012.M12	12	10	30
024.M070	24	21	36
.050.M038	50	45	61
.090.M019	90	81	73
.150.M013	150	135	120
.200.M0080	200	180	150
.300.M0053	300	260	225

CONNECTIONS

LINE			PE
Solid Cable (mm ²)	Stranded Cable (mm ²)	Terminal Block Torque (Nm)	Torque (Nm)
0.2 - 10	0.2 - 6	1.2	1.2
0.2 - 10	0.2 - 6	1.2	1.2
0.2 - 10	0.2 - 6	1.2	1.2
0.5 - 10	0.5 - 10	1.8	1.8
10 - 50	10 - 50	4.0	4.0
10 - 50	10 - 50	4.0	4.0
35 - 95	35 - 95	20	20
70 - 240	70 - 240	30	30

TYPICAL MEASUREMENT

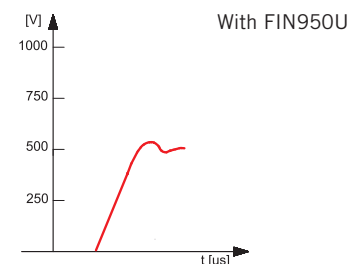
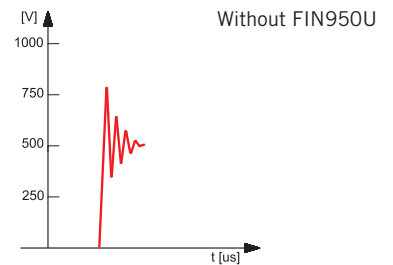

Example of measurement in a typical application using a servo drive

MECHANICAL DIMENSIONS mm

FIN950U	A	B	C	D	F	H	Weight Kg.	Case
.008.M20	150	125	100	55	7	250	2	1
.012.M12	150	125	100	55	7	250	3	1
024.M070	150	125	100	55	7	250	4	1
.050.M038	180	150	110	90	7	280	5	1
.090.M019	180	150	110	90	7	280	18	1
.150.M013	240	200	190	95	10	310	20	1
.200.M0080	240	200	190	95	10	310	26	1
.300.M0053	300	260	170	110	10	310	40	1

CASE 1

