

# DISPENSERS ST 200 AC

**MADE  
IN  
ITALY**

**EN.** High flow rate portable dispenser unit. ST 200 dispenses diesel fuel at a rate of up to 200 l/min and controls the flow with great precision (+/- 1%) thanks to the oval-gear flow meter (on request).

The low weight of the unit and the possibility of fitting wheels make it easy to handle and suitable for operating on worksites on vehicles with large storage tanks. The unit features a sturdy steel frame.

**ZH.** 便携式高流量加油机组。ST 200 DC可以185升/分钟的流量加注柴油，由于带有椭圆齿轮计量器(选配)，流量控制精确(+/- 1%)。

有限的重量及可安装轮子，令设备轻巧灵便，适合于在工地对带有巨型油箱的车辆进行加油。配备坚固的钢质支架。

**PT.** Grupo distribuidor portátil de grande capacidade. O ST 200 distribui o combustível Diesel até 200 l/min e controla o fluxo com precisão (+/- 1%), graças ao conta-litros de engrenagens ovais (a pedido).

O peso limitado e a possibilidade de instalar as rodas, o tornam manuseável e adequado para realizar abastecimentos em canteiros, nos veículos com reservatórios apropriados. Dotado de estrutura robusta em aço.

## PERFORMANCE

- Flow rate up to 200 l/min
- Continuous AC operation.
- Noise level below 75 dB

- 流量达200公升/分钟
- 交流电连续运作
- 噪音低于75 dB

- Caudal até 200 l/min
- Funcionamento contínuo AC
- Ruído inferior a 75 dB

## DIMENSIONS

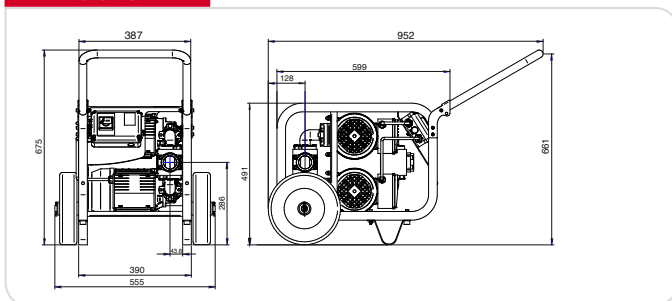

## PRODUCTS' RANGE WEIGHT AND PACKAGING

Code	Weight		Packaging		
	kg	lbs	mm	inch	pcs/box
F00315000	46	101	587x395x420	23,1x15,6x16,5	1
F16860000	-	-	-	-	-



**Flow-rate**  
up to  
**200** l/min  
(up to 52,7 gpm)



DISPENSERS

PUMPS

METERS

NOZZLE METERS

NOZZLE

SPECIAL EQUIPMENTS

FLUID MONITORING

ACCESSORIES

FILTERING

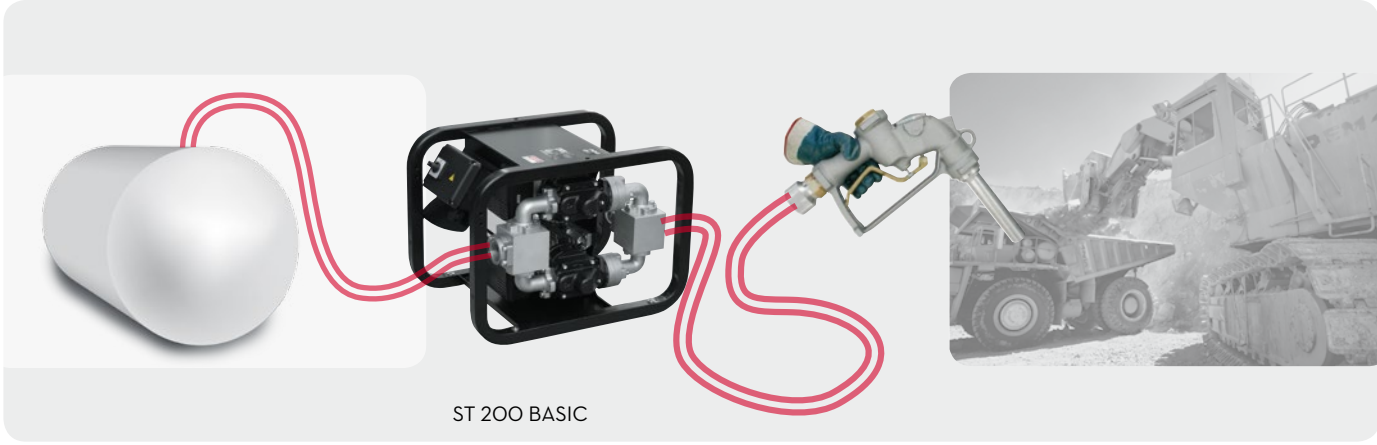

ST 200 BASIC

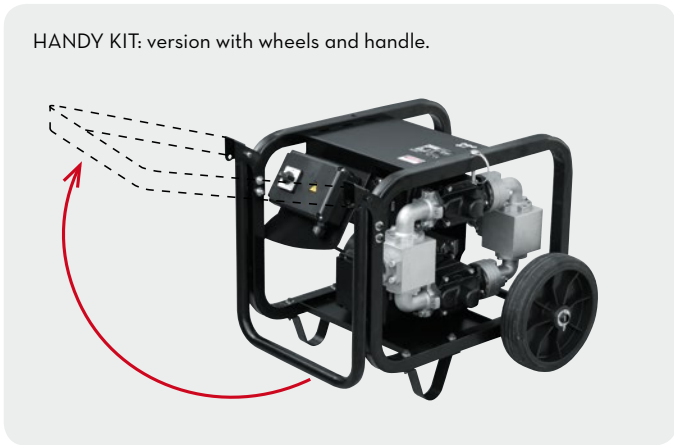

HANDY KIT: version with wheels and handle.

**FEATURES**



**ON REQUEST**



**Meter K700 M**  
Flow rate:  
20 - 220 l/min  
Accuracy: +/- 1%  
Oval gear system  
Code: F00540000



**Nozzle A280**  
Flow rate 280 l/min  
with swivel  
Code: F13249000



**Hose Kit 1" 1/2**  
Code: F18798000  
(delivery hose 10 mt + Camlock)  
Code: F18799000  
(delivery hose 20 mt + Camlock)

**PRODUCTS' RANGE TECHNICAL DATA**

Code	Description	Fluids type	Flow-rate		Voltage			Pump		Max pressure bar	Inlet BSP
			l/min	gpm	AC V./Hz	Power Watt	Amp. max.	mod.	no.		
F00315000	ST 200 BASIC	D	200	52,7	230/50	2050	10	E 120	2	2,5	1" 1/2
F16860000	HANDY KIT (handle + wheels)	D	-	-	-	-	-	-	-	-	-

Upon request it is available with different voltages and 60 Hz frequency