

Pilot Operated Relief Valves

These valves protect the hydraulic system from excessive pressure, and can be used to maintain constant pressure in a hydraulic system. Remote control and unloading are permitted by using vent circuits.

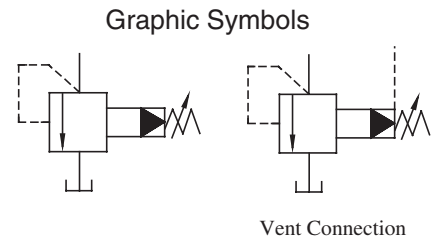
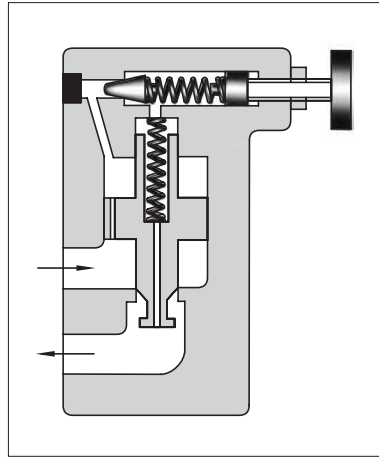

Specifications

Model Numbers		Max. Operating Pressure MPa (PSI)	Pres. Adj. Range MPa (PSI)	Max. Flow L/min (U.S.GPM)	Approx. Mass kg (lbs.)	
Threaded Connection	Sub-plate Mounting				BT type	BG type
BT-03-*-32*	BG-03-*-32*	25 (3630)	Note) ★-25 (★-3630)	100 (26.4)	5.0 (11.0)	4.7 (10.4)
BT-06-*-32*	BG-06-*-32*			200 (52.8)	5.0 (11.0)	5.6 (12.3)
BT-10-*-32*	BG-10-*-32*			400 (106)	8.5 (18.7)	8.7 (19.2)

Note: Refer to the Minimum adjustment Pressure characteristics on [page 214](#).

Model Number Designation

F-	B	T	-03	-V	-32	*
Special Seals	Series Number	Type of Mounting	Valve Size	High Venting* Pres. Feature	Design Number	Design Standards
F: Special Seals for Phosphate Ester Type Fluids (Omit if not required)	B: Pilot Operated Relief Valves	T: Threaded Connection	03	V: For High Venting Pressure Feature (Omit if not required)	32	None: Japanese Std. "JIS" 80: European Design Std. 90: N. American Design Std.
			06		32	
			10		32	
		G: Sub-plate Mounting	03		32	None: Japanese Std. "JIS" and European Design Std. 90: N. American Design Std.
			06		32	
			10		32	

★ Use high venting pressure type to reduce the response time from unload to onload.

■ Attachment

● Mounting Bolts

Valve Model Numbers	Socket Head Cap Screw	
	Japanese Std. "JIS" and European Design Std.	N. American Design Std.
BG-03	M12 × 70 Lg. (2 pcs.), M12 × 95 Lg. (2 pcs.)	1/2-13UNC × 2-3/4 Lg. (2 pcs.), 1/2-13UNC × 3-3/4 Lg. (2 pcs.)
BG-06	M16 × 60 Lg. (2 pcs.), M16 × 80 Lg. (2 pcs.)	5/8-11UNC × 2-1/4 Lg. (2 pcs.), 5/8-11UNC × 3-1/4 Lg. (2 pcs.)
BG-10	M20 × 70 Lg. (2 pcs.), M20 × 90 Lg. (2 pcs.)	3/4-10UNC × 2-3/4 Lg. (2 pcs.), 3/4-10UNC × 3-1/2 Lg. (2 pcs.)

■ Sub-plate

Valve Model Numbers	Japanese Standard "JIS"		European Design Standard		N. American Design Standard		Approx. Mass kg (lbs.)
	Sub-plate Model Numbers	Thread Size	Sub-plate Model Numbers	Thread Size	Sub-plate Model Numbers	Thread Size	
BG-03	BGM-03-20	Rc 3/8	BGM-03-3080	3/8 BSP.F	BGM-03-2090	3/8 NPT	2.4(5.3)
	BGM-03X-20	Rc 1/2	BGM-03X-3080	1/2 BSP.F	BGM-03X-2090	1/2 NPT	3.1(6.8)
BG-06	BGM-06-20	Rc 3/4	BGM-06-3080	3/4 BSP.F	BGM-06-2090	3/4 NPT	4.7(10.4)
	BGM-06X-20	Rc 1	BGM-06X-3080	1 BSP.F	BGM-06X-2090	1 NPT	5.7(12.6)
BG-10	BGM-10-20	Rc 1-1/4	BGM-10-3080	1-1/4 BSP.F	BGM-10-2090	1-1/4 NPT	8.4(18.5)
	BGM-10X-20	Rc 1-1/2	BGM-10X-3080	1-1/2 BSP.F	BGM-10X-2090	1-1/2 NPT	10.3(22.7)

- Sub-plates are available. Specify the sub-plate model number from the table above. When sub-plates are not used, the mounting surface should have a good machined finish.

■ Instructions

- If a remote control relief valve is used in the vent circuit, see [page 203](#). In addition, if the internal volume of the vent line is too large, chattering is likely to occur. Thus, as far as possible reduce the inside diameter and the length of the pipe.
- To adjust the pressure, loosen the lock nut and turn the handle slowly clockwise for higher pressures or anti-clockwise for lower pressures. After adjustments, do not forget to tighten the lock nut.
- Piping of the tank line should not be connected to any tank line of the other valves, but connected directly to the reservoir.
- Pressure is limited by collars fitted. If a working pressure cannot be attained, remove some collars. One collar is equivalent to 10 MPa (1450 PSI).
- With a small flow, the setting pressure may be unstable. Use models numbered 03 and 06 with a flow rate above 8 L/min (2.1 U.S. GPM) and model 10 with 15 L/min (4.0 U.S. GPM).

BT-03-*-32/3280/3290
 BT-06-*-32/3280/3290
 BT-10-*-32/3280/3290

DIMENSIONS IN
MILLIMETRES (INCHES)

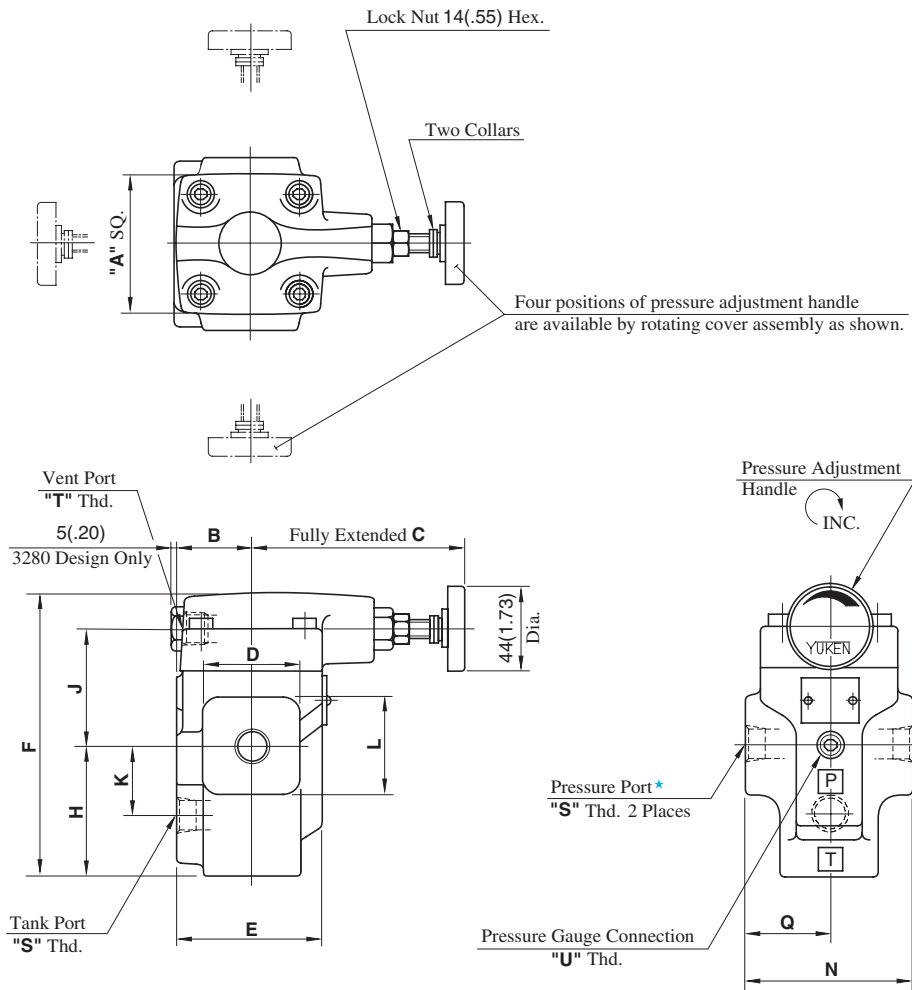

★ There are two threaded connection pressure ports. They can be connected each other in-line; one as inlet and the other as an outlet or the valve can be used by plugging one of the pressure ports.

Model Numbers	Dimensions mm (Inches)											
	A	B	C	D	E	F	H	J	K	L	N	Q
BT-03-*-32/3280/3290	75 (2.95)	40 (1.57)	105 (4.13)	52 (2.05)	78 (3.07)	150.5 (5.93)	68.5 (2.70)	62 (2.44)	36 (1.42)	52 (2.05)	90 (3.54)	45 (1.77)
BT-06-*-32/3280/3290												
BT-10-*-32/3280/3290	85 (3.35)	50 (1.97)	101 (3.98)	80 (3.15)	96 (3.78)	183 (7.20)	89 (3.50)	74 (2.91)	49 (1.93)	80 (3.15)	120 (4.72)	60 (2.36)

Model Numbers	Thread Size		
	"S" Thd.	"T" Thd.	"U" Thd.
BT-03-*-32	Rc 3/8	Rc 3/8	Rc 1/4
BT-03-*-3280	3/8 BSP.F	3/8 BSP.F	1/4 BSP.Tr
BT-03-*-3290	3/8 NPT	3/8 NPT	1/4 NPT
BT-06-*-32	Rc 3/4	Rc 3/8	Rc 1/4
BT-06-*-3280	3/4 BSP.F	3/8 BSP.F	1/4 BSP.Tr
BT-06-*-3290	3/4 NPT	3/8 NPT	1/4 NPT
BT-10-*-32	Rc 1-1/4	Rc 3/8	Rc 1/4
BT-10-*-3280	1-1/4 BSP.F	3/8 BSP.F	1/4 BSP.Tr
BT-10-*-3290	1-1/4 NPT	3/8 NPT	1/4 NPT



BG-03-*-32/3290
 BG-06-*-32/3290
 BG-10-*-32/3290

**DIMENSIONS IN
 MILLIMETRES (INCHES)**

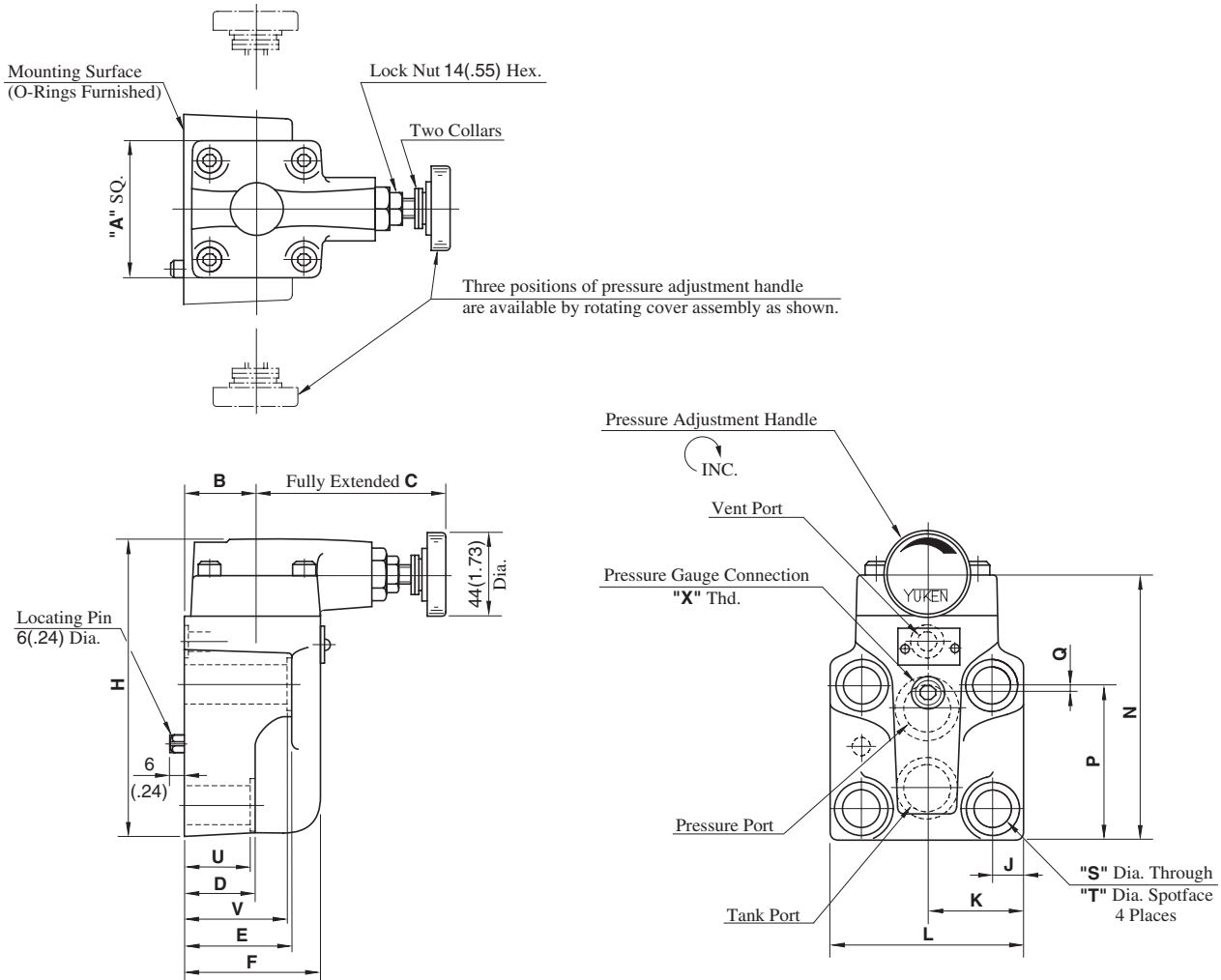

Model Numbers	Dimensions mm (Inches)																
	A	B	C	D	E	F	H	J	K	L	N	P	Q	S	T	U	V
BG-03-*-32/3290	75 (2.95)	40 (1.57)	105 (4.13)	57 (2.24)	78 (3.07)	78 (3.07)	137 (5.39)	14.1 (.56)	41 (1.61)	82 (3.23)	117 (4.61)	77 (3.03)	22 (.87)	13.5 (.53)	21 (.83)	55 (2.17)	77 (3.03)
BG-06-*-32/3290	75 (2.95)	40 (1.57)	105 (4.13)	40 (1.57)	60 (2.36)	78 (3.07)	161 (6.34)	17 (.67)	52 (2.05)	104 (4.09)	141 (5.55)	83.5 (3.29)	4.5 (.18)	17.5 (.69)	26 (1.02)	38 (1.50)	58 (2.28)
BG-10-*-32/3290	85 (3.35)	45 (1.77)	101 (3.98)	47 (1.85)	67 (2.64)	87.5 (3.44)	195 (7.68)	20.7 (.81)	62 (2.44)	124 (4.88)	175 (6.89)	110 (4.33)	6 (.24)	21.5 (.85)	32 (1.26)	45 (1.77)	65 (2.56)

Model Numbers	Thread Size	Mounting Surface
	"X" Thd	
BG-03-*-32	Rc 1/4 = 1/4 BSP.Tr	ISO 6264-AR-06-2-A
BG-03-*-3290	1/4 NPT	
BG-06-*-32	Rc 1/4 = 1/4 BSP.Tr	ISO 6264-AS-08-2-A
BG-06-*-3290	1/4 NPT	
BG-10-*-32	Rc 1/4 = 1/4 BSP.Tr	ISO 6264-AT-10-2-A
BG-10-*-3290	1/4 NPT	

BGM-03,03X-20 / 3080 / 2090
 BGM-06,06X-20 / 3080 / 2090
 BGM-10,10X-20 / 3080 / 2090

DIMENSIONS IN
 MILLIMETRES (INCHES)

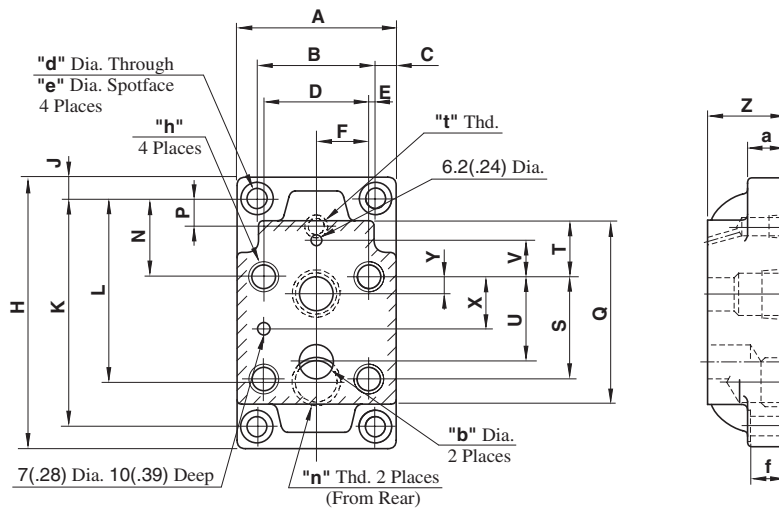

Model Numbers	Dimensions mm (Inches)													
	A	B	C	D	E	F	H	J	K	L	N	P	Q	S
BGM-03	86	60	13	53.8	3.1	26.9	149	13	123	86	32	26	97	53.8
BGM-03X	(3.39)	(2.36)	(.51)	(2.12)	(.12)	(1.06)	(5.87)	(.51)	(4.84)	(3.39)	(1.26)	(1.02)	(3.82)	(2.12)
BGM-06	108	78	15	70	4	35	180	15	150	106.5	51	27.2	121	66.7
BGM-06X	(4.25)	(3.07)	(.59)	(2.76)	(.16)	(1.38)	(7.09)	(.59)	(5.91)	(4.19)	(2.01)	(1.07)	(4.76)	(2.63)
BGM-10	126	94	16	82.6	5.7	41.3	227	16	195	138.2	62	30.2	154	88.9
BGM-10X	(4.96)	(3.70)	(.63)	(3.25)	(.22)	(1.63)	(8.94)	(.63)	(7.68)	(5.44)	(2.44)	(1.19)	(6.06)	(3.50)

Model Numbers	Dimensions mm (Inches)										
	T	U	V	X	Y	Z	a	b	d	e	f
BGM-03	19	47.4	0	22	22	32	20	14.5	11	17.5	19
BGM-03X	(.75)	(1.87)	(0)	(.87)	(.87)	(1.26)	(.79)	(.57)	(.43)	(.69)	(.75)
BGM-06	37	55.5	23.8	33.4	11	40	25	23	13.5	21	24
BGM-06X	(1.46)	(2.19)	(.94)	(1.31)	(.43)	(1.57)	(.98)	(.91)	(.53)	(.83)	(.94)
BGM-10	42	76.2	31.8	44.5	12.7	50	32	28	17.5	26	31
BGM-10X	(1.65)	(3.00)	(1.25)	(1.75)	(.50)	(1.97)	(1.26)	(1.10)	(.69)	(1.02)	(1.22)

Model Numbers	Japanese Standard "JIS" Design "20"			European Design Standard Design "3080"			N. American Design Standard Design "2090"		
	"h"	"n" Thd.	"t" Thd.	"h"	"n" Thd.	"t" Thd.	"h"	"n" Thd.	"t" Thd.
BGM-03	M12 Thd.	Rc 3/8	Rc 1/4	M12 Thd.	3/8 BSP.F	1/4 BSP.F	1/2-13UNC Thd.	3/8 NPT	1/4 NPT
BGM-03X	20(.79) Deep	Rc 1/2		20(.79) Deep	1/2 BSP.F		22(.87) Deep	1/2 NPT	
BGM-06	M16 Thd.	Rc 3/4		M16 Thd.	3/4 BSP.F		5/8-11UNC Thd.	3/4 NPT	
BGM-06X	25(.98) Deep	Rc 1		25(.98) Deep	1 BSP.F		27(1.06) Deep	1 NPT	
BGM-10	M20 Thd.	Rc1-1/4	M20 Thd.	1-1/4 BSP.F	3/4-10UNC Thd.	1-1/4 NPT			
BGM-10X	28(1.10) Deep	Rc 1-1/2	28(1.10) Deep	1-1/2 BSP.F	28(1.10) Deep	1-1/2 NPT			



Nominal Override Characteristics

Hydraulic fluid: Viscosity : 35 mm²/s (164 SSU)
Specific Gravity : 0.850

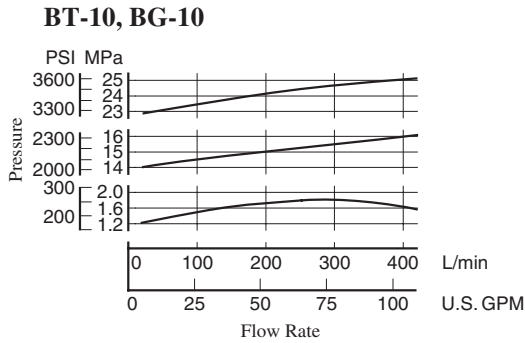
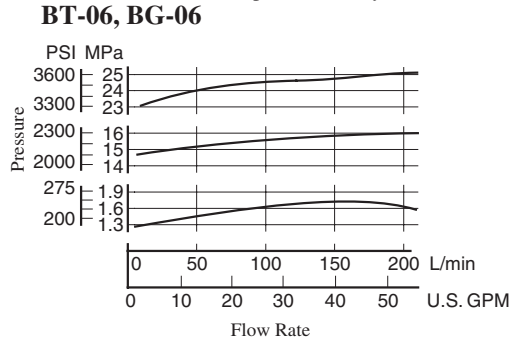
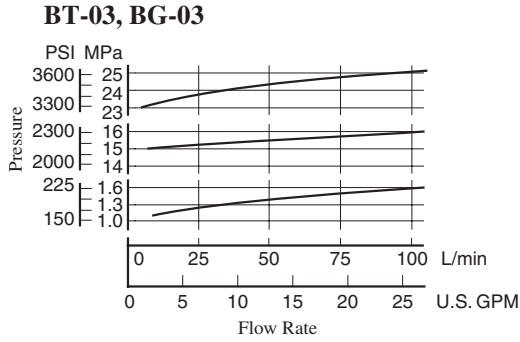

Min. Adj. Pressure & Vent Pressure vs. Flow

Hydraulic fluid: Viscosity : 35 mm²/s (164 SSU)
Specific Gravity : 0.850

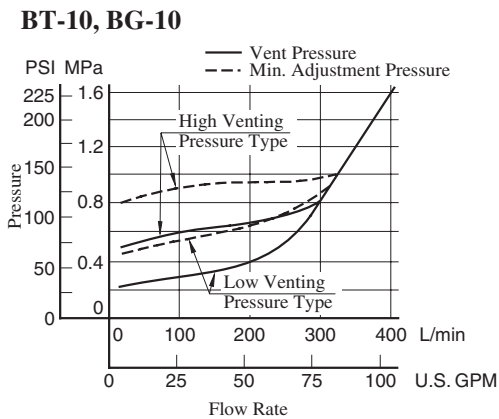
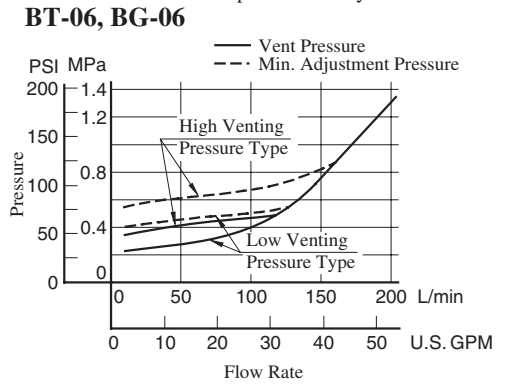
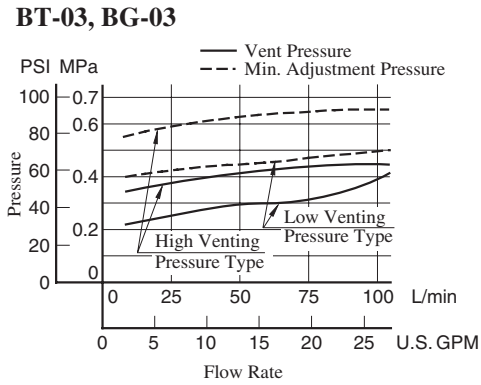

Spare Parts List

BT-03-* -32/3280/3290

BT-06-* -32/3280/3290

BT-10-* -32/3280/3290

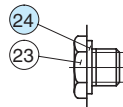
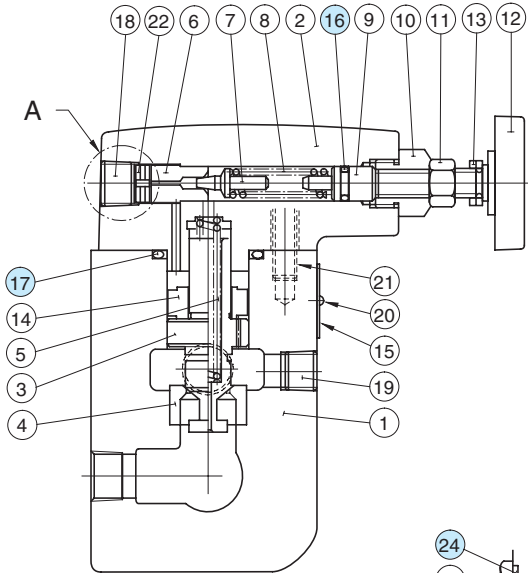

Section "A"
for Design 3280

List of Seals

Item	Name of Parts	Part Numbers			Qty.
		BT-03	BT-06	BT-10	
16	O-Ring	SO-NA-P9	SO-NA-P9	SO-NA-P9	1
17	O-Ring	SO-NB-P32	SO-NB-P42	SO-NB-P42	1
24	Bonded Seal	SG-FB-3/8	SG-FB-3/8	SG-FB-3/8	1

Note: When ordering the seals, please specify the seal kit number from the table below.

List of Seal Kits

Valve Model Numbers	Seal Kit Numbers
BT-03	KS-BT-03-32
BT-06	
BT-10	KS-BT-10-32

Note: No bonded seals are included in the seal kits.

BG-03-* -32/3290

BG-06-* -32/3290

BG-10-* -32/3290

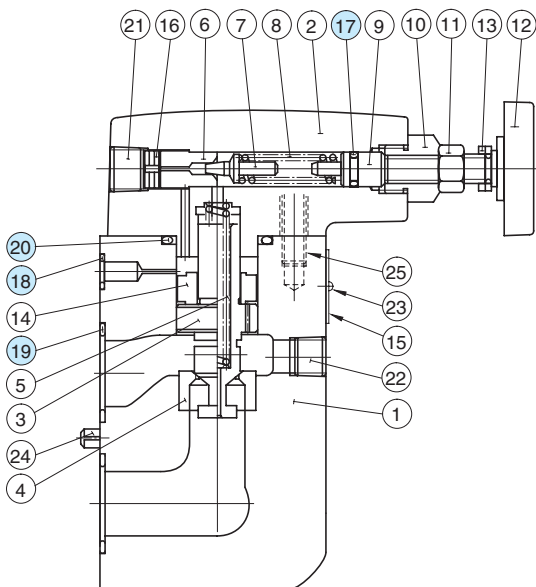

List of Seals

Item	Name of Parts	Part Numbers			Qty.
		BG-03	BG-06	BG-10	
17	O-Ring	SO-NA-P9	SO-NA-P9	SO-NA-P9	1
18	O-Ring	SO-NB-P9	SO-NB-P11	SO-NB-P9	1
19	O-Ring	SO-NB-P18	SO-NB-P28	SO-NB-P32	2
20	O-Ring	SO-NB-P32	SO-NB-P32	SO-NB-P42	1

Note: When ordering the seals, please specify the seal kit number from the table below.

List of Seal Kits

Valve Model Numbers	Seal Kit Numbers
BG-03	KS-BG-03-32
BG-06	KS-BG-06-32
BG-10	KS-BG-10-32