

## Unloading Relief Valves

These valves are used to operate the pumps with minimum load in accumulator circuits or in high-low pump circuits.

In accumulator circuits, when the system pressure reaches to a cut out pressure (adjusted maximum), the valve acts to divert the pump delivery to the reservoir at low pressure, thus the pump is unloaded automatically.

When the accumulator pressure drops to the cut in pressure (refer to characteristic chart on page 269), the valve directs the pump delivery to the accumulator and hydraulic system.

An integral check valve prevents reverse flow through the valve from the accumulator.

In high-low pump circuits, the valve acts to unload the large volume pump with the same manner as described above during load operation of the small volume pump.

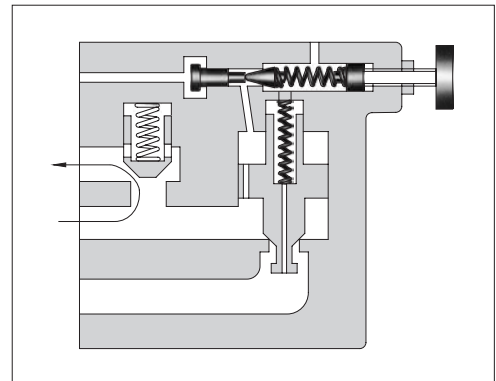

Unloading Relief Valves

### Specifications

Model Numbers	Max. Operating Pres. MPa (PSI)	Max. Flow L/min (U.S.GPM)	Approx. Mass kg (lbs.)
BUCG-06-**-30/3080/3090	21 (3050)	125 (33)	12 (26.5)
BUCG-10-**-25/2580/2590		250 (66)	21.5 (47.4)

### Model Number Designation

F-	BUC	G	-06	-B	V	-30	*
Special Seals	Series Number	Type of Mounting	Valve Size	Cut-out Pres. Adj. Range MPa (PSI)	High Venting* Pres. Feature	Design Number	Design Standards
<b>F:</b> Special Seals for Phosphate Ester Type Fluids (Omit if not required)	<b>BUC:</b> Unloading Relief Valve	<b>G:</b> Sub-plate Mounting	<b>06</b> <b>10</b>	<b>B:</b> 2.5-7.0 (360-1020) <b>C:</b> 3.5-14 (510-2030) <b>H:</b> 7.0-21 (1020-3050)	<b>V:</b> For High Venting Pressure Feature (Omit if not required)	<b>30</b> <b>25</b>	<b>None:</b> Japanese Std. "JIS" <b>80:</b> European Design Std. <b>90:</b> N. American Design Std.

★ Use the high-venting-pressure type to reduce the shift time from unloading to onloading.

### Pilot-drain system

A pilot-drain system is typically configured with an external pilot and an external drain, as indicated by the right graphic symbol. However, customized pilot-drain systems with an internal pilot are also available.

For the internal pilot type, the design standard number at the end of the model number is uniquely assigned. Refer to the table below for the internal pilot type. Please contact us for details.

Pilot & Drain Conn.	Graphic Symbols	European Design Standard	N. American Design Standard	Japanese Std. "JIS"
Int. Pilot- Int. Drain		BUCG-06-**-30801 BUCG-10-**-25801	BUCG-06-**-30901 BUCG-10-**-25901	BUCG-06-**-3001 BUCG-10-**-2501
Int. Pilot- Ext. Drain		BUCG-06-**-30802	BUCG-06-**-30902	BUCG-06-**-2502

Graphic Symbol

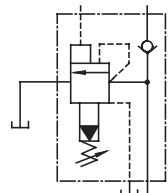

**■ Instructions**

- To adjust the pressure, loosen the lock nut and turn the pressure adjustment handle slowly clockwise for higher pressures or anti-clockwise for lower pressures. After adjustments, do not forget to tighten the lock nut.
- Take care not to neglect connecting the drain pipe to the reservoir; otherwise not only will the valve fail to operate properly but also the line pressure will rise infinitely. Extend the end of the drain pipe into fluid.
- Limit the pressure drop between the valve and the accumulator in an accumulator circuit below 10% of the cut-out pressure.
- Limit the drain port back pressure below 2% of the cut-out pressure.

**■ Attachment**

**● Mounting Bolts**

Valve Model Numbers	Socket Head Cap Screw	
	Japanese Std. "JIS" and European Design Std.	N. American Design Std.
BUCG-06	M16 × 55Lg. (2 pcs.)	5/8-11 UNC × 2-1/4 Lg. (2 pcs.)
	M16 × 110Lg. (2 pcs.)	5/8-11 UNC × 4-1/2 Lg. (2 pcs.)
	M16 × 130Lg. (2 pcs.)	5/8-11 UNC × 5 Lg. (2 pcs.)
BUCG-10	M20 × 70Lg. (2 pcs.)	3/4-10 UNC × 2-3/4 Lg. (2 pcs.)
	M20 × 160Lg. (4 pcs.)	3/4-10 UNC × 6-1/2 Lg. (4 pcs.)

**■ Sub-plate**

Valve Model Numbers	Japanese Standard "JIS"		European Design Standard		N. American Design Standard		Approx. Mass kg (lbs.)
	Sub-plate Model Numbers	Thread Size	Sub-plate Model Numbers	Thread Size	Sub-plate Model Numbers	Thread Size	
BUCG-06	BUCGM-06-20	Rc 3/4	BUCGM-06-2080	3/4 BSP.F	BUCGM-06-2090	3/4 NPT	4.4 (9.7)
BUCG-10	BUCGM-10-20	Rc 1-1/4	BUCGM-10-2080	1-1/4 BSP.F	BUCGM-10-2090	1-1/4 NPT	7.2 (15.9)

- Sub-plates are available. Specify the sub-plate model number from the table above. When sub-plates are not used, the mounting surface should have a good machined finish.

**BUCG-06-\*\*-30/3080/3090**

Model Numbers	"A" Thd.	"B" Thd.
BUCG-06-**-30	Rc 1/4	Rc 1/4
BUCG-06-**-3080	1/4 BSP.Tr	1/4 BSP.F
BUCG-06-**-3090	1/4 NPT	1/4 NPT

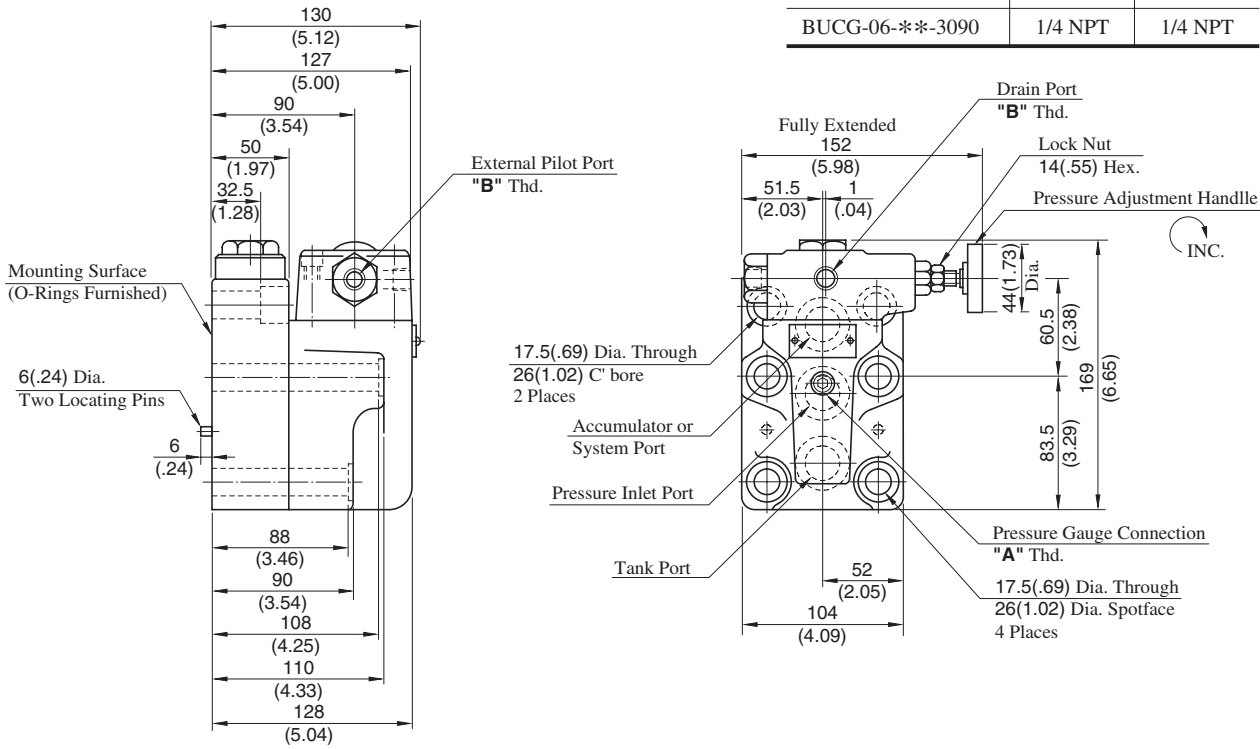

**DIMENSIONS IN MILLIMETRES (INCHES)**

**Sub-plate**

**BUCGM-06-20/2080/2090**

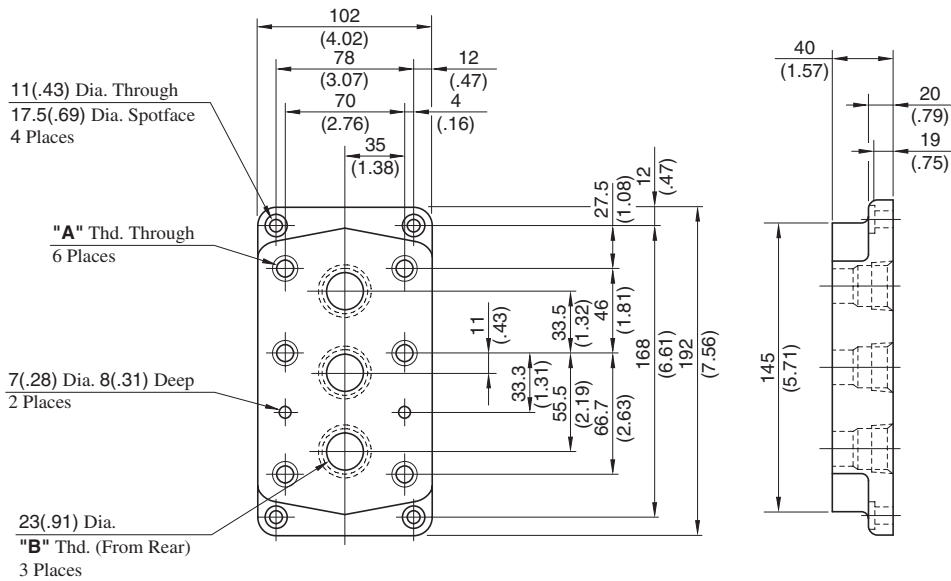

Sub-plate Model No.	"A" Thd.	"B" Thd.
BUCGM-06-20	M16	Rc 3/4
BUCGM-06-2080	M16	3/4 BSP.F
BUCGM-06-2090	5/8-11 UNC	3/4 NPT

**Unloading Relief Valves**

**BUCG-10-\*\*-25/2580/2590**

Model Numbers	"A" Thd.	"B" Thd.
BUCG-10-**-25	Rc 1/4	Rc 1/4
BUCG-10-**-2580	1/4 BSP.Tr	1/4 BSP.F
BUCG-10-**-2590	1/4 NPT	1/4 NPT

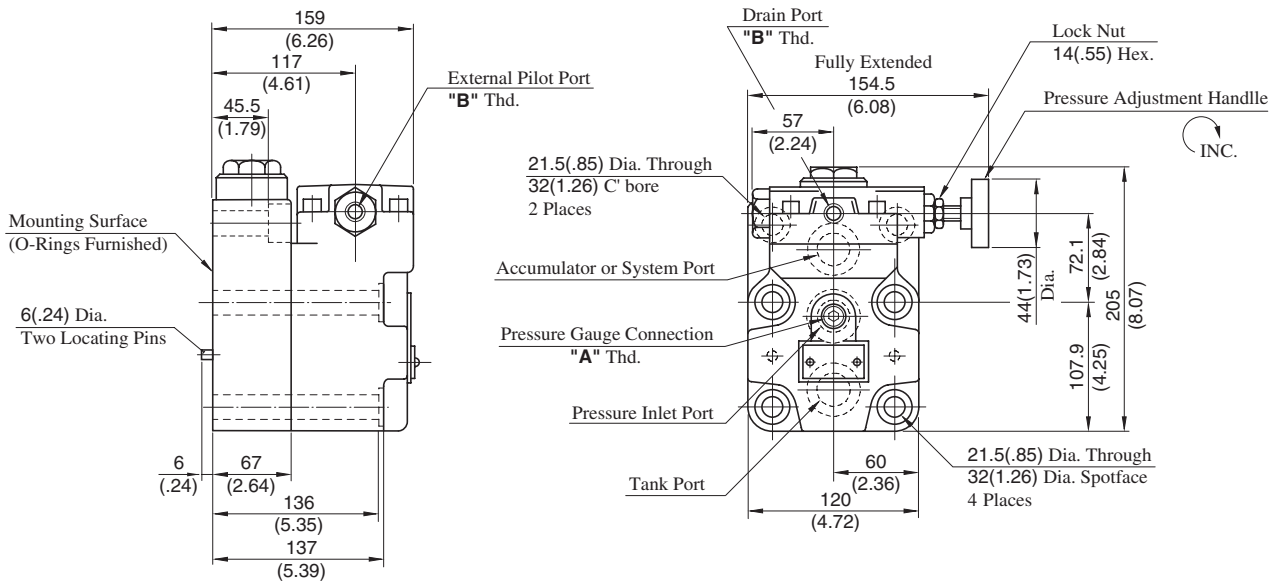

**DIMENSIONS IN MILLIMETRES (INCHES)**

**■ Sub-plate**

**BUCGM-10-20/2080/2090**

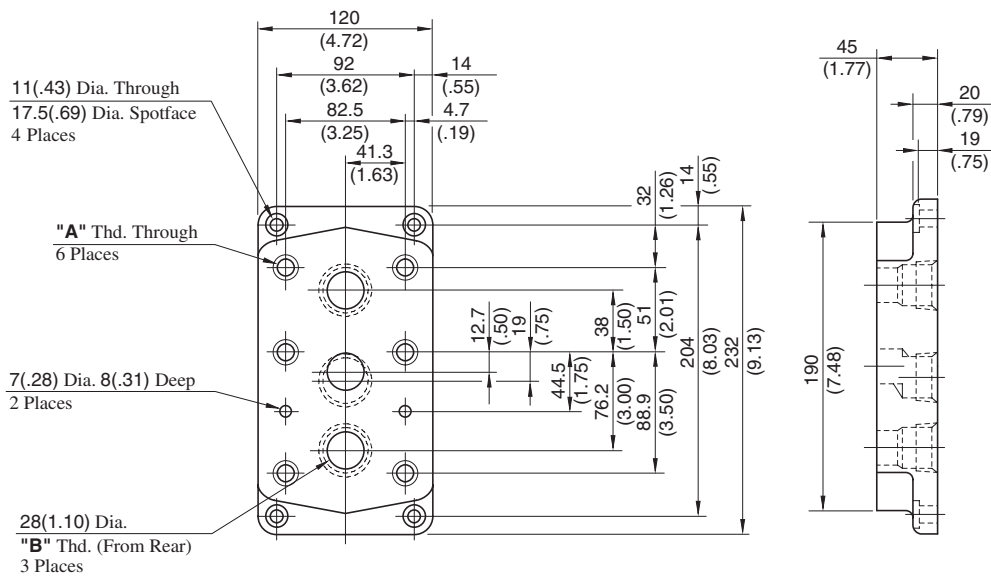

Sub-plate Model No.	"A" Thd.	"B" Thd.
BUCGM-10-20	M20	Rc 1-1/4
BUCGM-10-2080	M20	1-1/4 BSP.F
BUCGM-10-2090	3/4-10 UNC	1-1/4 NPT

## Cut-in Pressure vs. Cut-out Pressure

Hydraulic Fluid: Viscosity 35 mm<sup>2</sup>/s (164 SSU), Specific Gravity 0.850

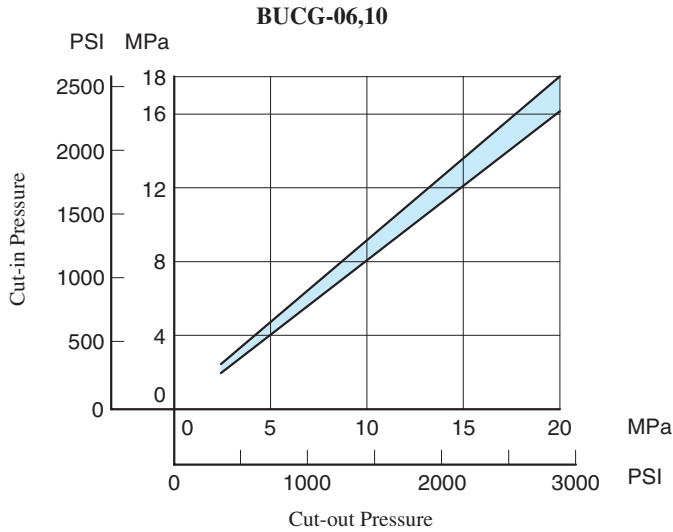

## Unloading Pressure vs. Flow

Hydraulic Fluid: Viscosity 35 mm<sup>2</sup>/s (164 SSU), Specific Gravity 0.850

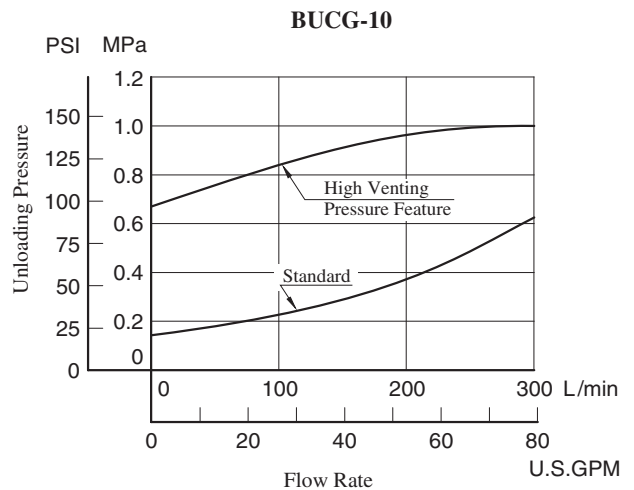
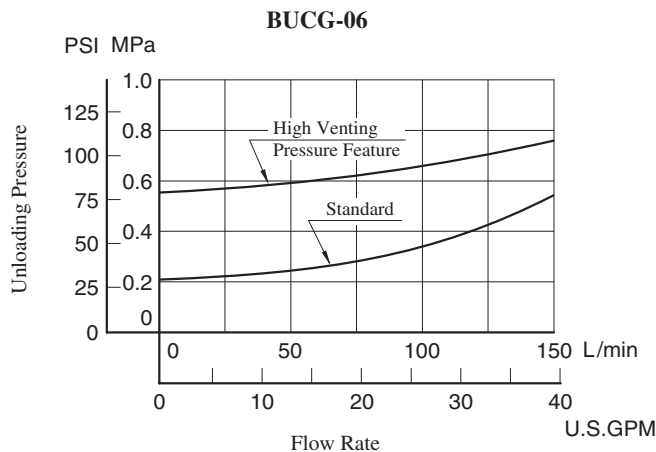

## Pressure Drop for Check Valve

Hydraulic Fluid: Viscosity 35 mm<sup>2</sup>/s (164 SSU), Specific Gravity 0.850

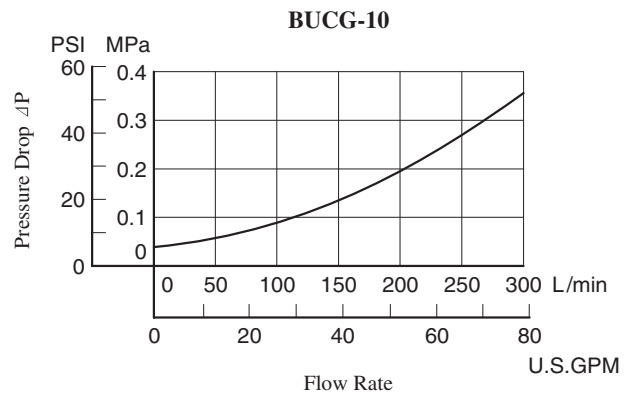
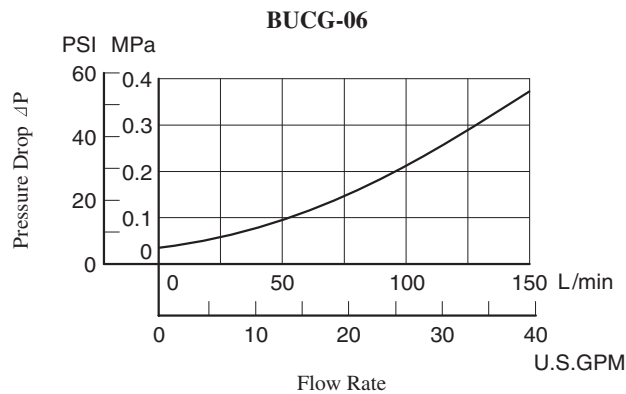

• For any other viscosity, multiply the factors in the table below.

Viscosity	mm <sup>2</sup> /s	15	20	30	40	50	60	70	80	90	100
		SSU	77	98	141	186	232	278	324	371	417
Factor		0.81	0.87	0.96	1.03	1.09	1.14	1.19	1.23	1.27	1.30

• For any other specific gravity (G'), the pressure drop (ΔP') may be obtained from the formula below.

$$\Delta P' = \Delta P (G'/0.850)$$

■ Spare Parts List

BUCG-06-\*\*-30/3080/3090  
 BUCG-10-\*\*-25/2580/2590

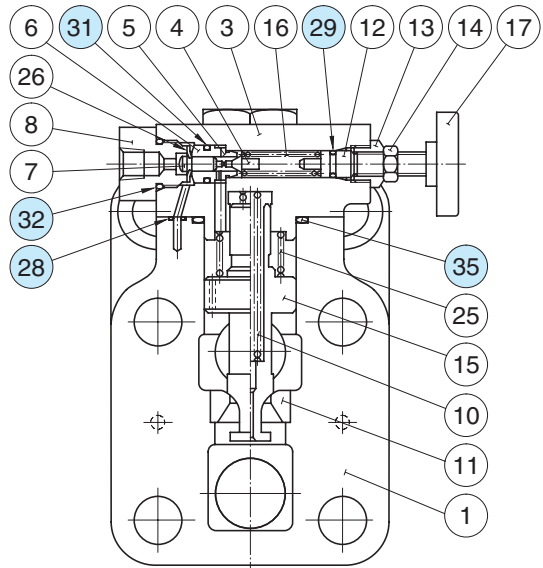
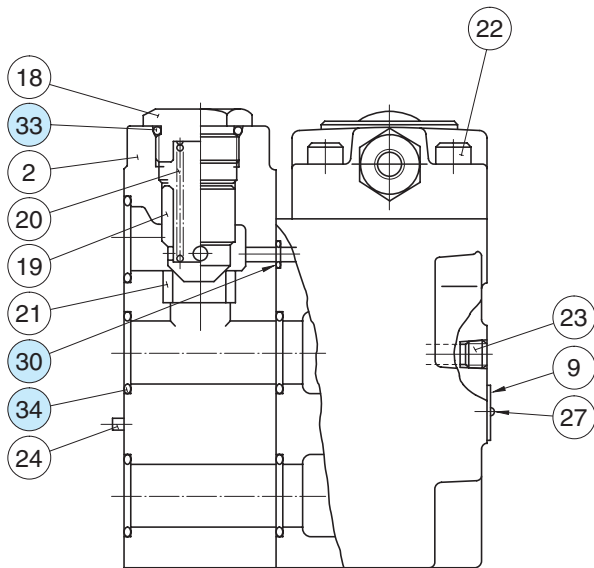

● List of Seals

Item	Name of Parts	Part Numbers		Quantity
		BUCG-06	BUCG-10	
28	O-Ring	SO-NB-P6	SO-NB-P6	3
29	O-Ring	SO-NA-P9	SO-NA-P9	1
30	O-Ring	SO-NB-P11	SO-NB-P9	1
31	O-Ring	SO-NB-P12	SO-NB-P12	1
32	O-Ring	SO-NB-P18	SO-NB-P18	1
33	O-Ring	SO-NB-P24	SO-NB-P32	1
34	O-Ring	SO-NB-P28	SO-NB-P32	5
35	O-Ring	SO-NB-P32	SO-NB-P45	1

Note: When ordering the seals, please specify the seal kit number from the table below.

● List of Seal Kits

Valve Model Numbers	Seal Kit Numbers
BUCG-06	KS-BUCG-06-30
BUCG-10	KS-BUCG-10-25