

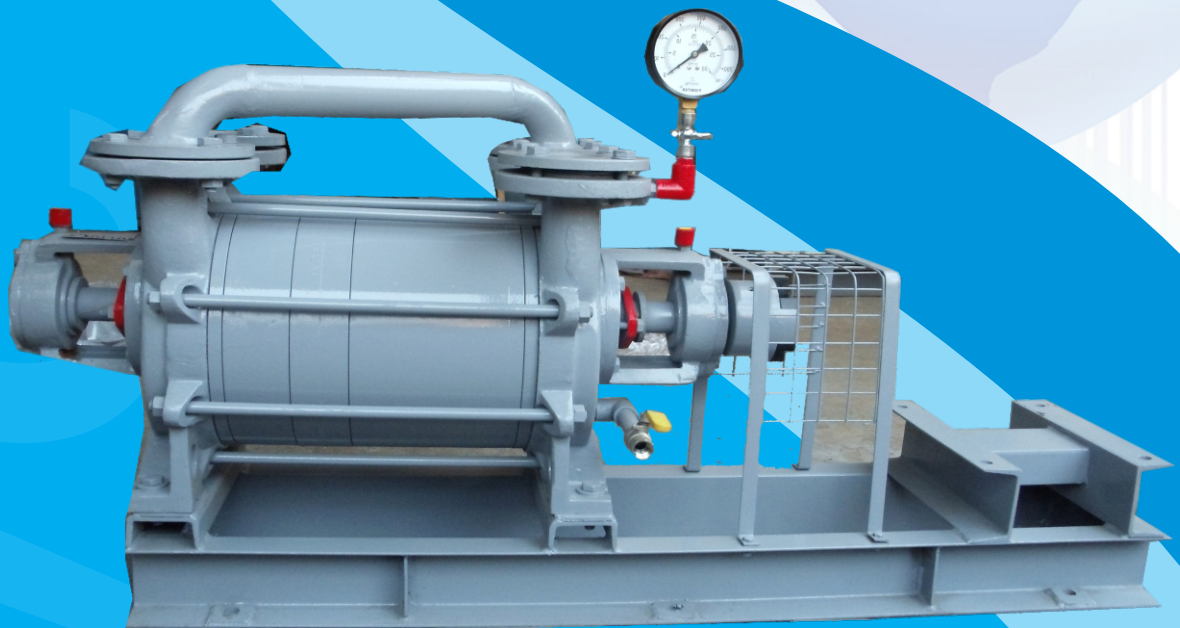

IVC
PUMPS PVT. LTD.



Two Stage Vacuum Pump



IVC PUMPS PVT. LTD.

TWO STAGE VACUUM PUMP

"IVC" Two Stage Liquid Ring Vacuum Pumps are better design than single stage vacuum pumps, having advantage of higher capacity at high vacuum and also requires low quantity of water at low pressure compare to single stage vacuum pump. Two stage vacuum pump develops maximum vacuum of 720 mm of hg, when sealing water temperature is 30°C (755 mm of hg barometric pressure & suction temperature of 30°C) due to its latest technology and design, it so happen that a smaller model may require as compare to single stage vacuum pump.

APPLICATION :

- Dehydration and filtration processes
- Distillation , Evaporation & Drying
- Deodorization, Evacuation
- Sterilizing, Conveying
- Venting & Sucking
- Moisture Extraction, Concentration

SALIENTS FEATURES :

- Simple & Rugged Construction
- Trouble free operation
- Easily handle dust laded gases
- There no Teflon Ball Inside the Pump to Deteriorate Vacuum Performance Compare to Single Stage Vacuum Pump

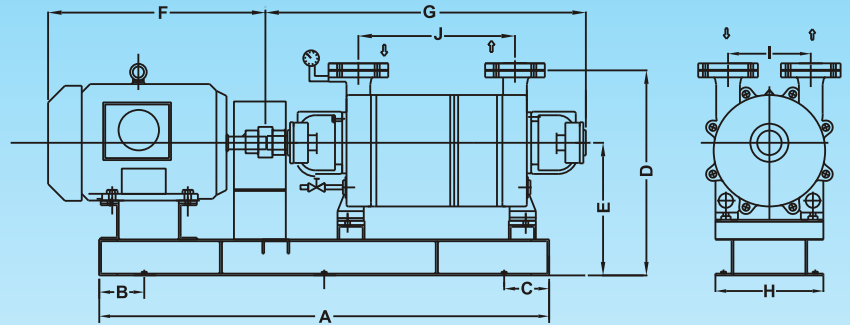

RANGE

- Capacity : 81 M³/hr. to 1200 M³/hr.
- Vacuum : 720 mm of Hg.
- Power : 5 HP to 50 HP

MODEL	A	B	C	D	E	F	G	H	I	J
IVT-5	900	150	150	485	320	385	615	275	200	270
IVT-7	1000	150	150	485	320	470	705	275	200	370
IVT-10	1100	150	150	568	368	508	785	320	235	465
IVT-15	1250	125	125	568	368	581	885	320	235	575
IVT-20	1450	125	125	568	368	625	1020	320	235	720
IVT-25	1500	150	150	590	370	647	986	340	240	566
IVT-30	1500	150	150	590	370	720	1020	340	240	600
IVT-40	1780	140	140	685	325	785	1225	400	250	735

MATERIAL OF CONSTRUCTION

Cast Iron, SS 304, SS 316, Bronze, Gun Metal & As per process Requirement

- Water Re-circulation Possible Without Extra Power Consumption.

DETAIL TECHNICAL SPECIFICATION

Pump Model	Max. Capacity (M ³ /hr)	Water Reqd. (LPM)	Rec.Motor HP/RPM
IVT-5	90	7	5/1450
IVT-7	160	9	7.5/1450
IVT-10	220	14	10/1450
IVT-12	250	16	12.5/1450
IVT-15	330	20	15/1450
IVT-20	460	24	20/1450
IVT-25	580	30	25/1450
IVT-30	725	40	30/1450
IVT-40	1000	60	40/1450
IVT-60	1400	90	60/980
IVT-90	1800	120	90/1450

OTHER PRODUCTS

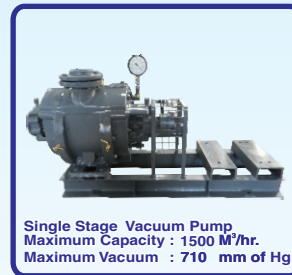

(AN ISO 9001-2008 COMPANY)



IVC PUMPS PVT. LTD.



Edited with Infix PDF
- free for non-commercial use

To remove this notice
www.iceni.com/unlock

Smaller and larger capacity pump can offered on request.
We reserve the right to change the specifications without prior notice