



ULTRA UF- II

METER SIZES : 80, 81, 82, 83, 84, 85, 86, 87, 88
Register types UA, UB, and UD

GENERAL SPECIFICATION

GS.No.GBL108E-6

■ GENERAL

ULTRA UF-II is the typical positive displacement type flowmeter installed a multiple functioned register (ULTRA Register) and is mainly applied to tank truck loading system for transaction of petroleum products.

The exclusive flowmeter features minimized noise and vibration with use of a couple of the specially designed spiral rotors and allows high accuracy flow measurement with wide rangeability.

■ FEATURES

1. Equalized rotating speed and torque of rotors and non fractured flow rate can be obtained continuously by the special spiral rotors. Low level of rotation noise and vibration are guaranteed. Uniform motion of the rotors reduces pressure loss through the meter.
2. High level of durability can be maintained during operation because there's no sliding contact in the meshing point of rotors alternately.
3. Large quantity per revolution and higher allowable rotating speed of the rotors make the maximum flowrate of flowmeter larger for the compact size.
4. The measuring chamber is simply composed of a couple of the rotors without attachment of a pilot gear for each.
5. Microprocessor-based ULTRA register indicates variables- total flow, both resettable and cumulative, instantaneous flowrate,selectable with mode select switch, plus alarm (low battery alarm) on the LCD.
6. Output signal is available in two channels simultaneously in the form of total flow (4/20 mA DC scaled or unscaled current pulse) and instantaneous flowrate signal (4 to 20mADC analog).
7. A complete series of explosionproof model also available.
8. With batch controller equipped ULTRA register, you can simply and readily build a batch control system.

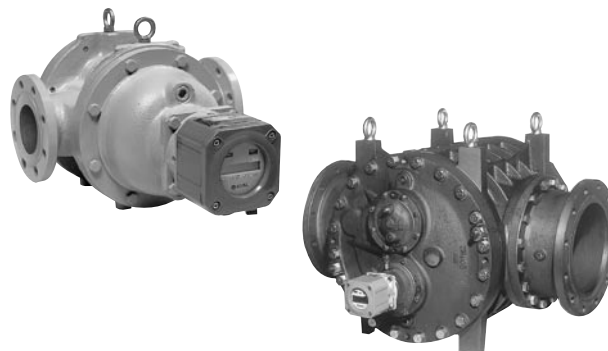

■ GENERAL SPECIFICATIONS

● Meter Body (Meter sizes : 80, 81)

Item		Description	
Meter size		80	81
Nominal size, mm		100 (4"), ▲80 (3")	100 (4")
Flange rating		FC250・・JIS 10K FF, ASME 125 FF SCPH2・・JIS 10K RF, ASME/JPI 150 RF	
Applicable fluid		Gasoline, Kerosene, Gas oil, Fuel oil, and other Petroleum products (except Naphtha, LPG)	
Flow range		See flow range table (page 3.)	
Operating temp. range	Process	-5 to +120°C (FC250 : 0 to 120°C)	
	Ambient	More than -10°C	
Max. operating pressure		0.98 MPa for FC250, 1.37MPa for SCPH2	
Linearity		±0.15%	
Materials	Bodys	FC250 (Cast iron) + Surface treatment or SCPH2 (Cast steel) + Surface treatment	
	Rotor	FC250+Surface treatment	
	Bearing	Carbon	
Flow direction		Right → Left (std.), Left → Right, Bottom → Top, Top → Bottom	
Finish		Munsell 2.5G 8/2	

▲ : Special

● Meter Body (Meter sizes : 82, 83, 84, 85, 86, 87, 88)

Item		Description						
Meter size		82	83	84	85	86	87	88
Nominal size, mm		150 (6") ▲100 (4")	200 (8") ▲150 (6")	250 (10") ▲200 (8")	300 (12") ▲250 (10")	350 (14") ▲300 (12")	400 (16") ▲350 (14")	450 (18") ▲400 (16")
Flange rating		JIS 10K RF, JIS 20K RF, ASME/JPI 150 RF						
Applicable fluid		Gasoline, Kerosene, Gas oil, Fuel oil, and other Petroleum products (except Naphtha)						
Flow range		See flow range table (page 3.)						
Operating temp. range	Process	-5 to +120°C						
	Ambient	More than -10°C						
Max. operating pressure		1.96MPa						
Linearity		±0.35% or ±0.15%						
Materials	Bodys	SCPH2 or SCPH2 (Cast steel) + Surface treatment						
	Rotor	FC250 or FC250+Surface treatment						
	Bearing	Carbon						
Flow direction		Right → Left (std.), Left → Right, Bottom → Top, Top → Bottom						
Finish		Munsell 2.5G 8/2						

▲ : Special

OVAL Corporation

<http://www.oval.co.jp/english>

Head Office (Tokyo): Tel. +81 3-3360-5121 Fax. +81 3-3365-8605
International Sales Division Email: SK10@oval.co.jp
Overseas Branch Offices: Beijing, Seoul, Singapore, Taipei

● Register Specifications

Item		Description			
Meter size		80, 81		82, 83, *84	
Local displa (LCD) (*2)	Cumulative totalizing counter		0.001 m ³ (std.)	0.001 m ³ (std.)	
	Reset counter, 7digits	C mode	0.01 m ³ , 0.1 m ³	0.01 m ³ , 0.1 m ³	
	Instantaneous flowrate (5 digits)	b1 mode	0.1 m ³ /h	0.1 m ³ /h	
		b2 mode	0.001 m ³ /min	0.001 m ³ /min	
Output signal	None		Local LCD only		
	Current	Analog		4 to 20mADC Refer to diagram, page 5.	
		Pulse (*4, *5)	Type	Scaled or unscaled: 0/1=4/20 mADC	
			Pulse width	Scaled: 1ms (std.), 50 ms	Unscaled: 2ms
	Unit of scaled pulse		Same as of LCD counter (*1)		
	Open collector	Type		Scaled or unscaled: Max. V: 30 VDC allowable current: 50 mA	
		Pulse (*4, *5)	Pulse width	Scaled: 1ms (std.), 50 ms	Unscaled: 2ms
			Unit of scaled pulse	Same as of LCD counter (*1)	
	Voltage	Type		Scaled or unscaled: 0/1=1 VDC Max./7VDC Min.	
		Pulse (*4, *5)	Pulse width	Scaled: 1ms (std.), 50 ms	Unscaled: 2ms
Unit of scaled pulse			Same as of LCD counter (*1)		
Power supply	Without output signal		Installed lithium battery	Life: 8 years(2 years with explosionproof construction ④ and ⑤)	
	With output signal		External power source: 12 to 45 VDC (Analog or current pulse) 12 to 24 VDC (Open collector pulse or voltage pulse) 12 to 45 VDC (Combination analog and current pulse) Current consumption: Max. 30 mADC Refer to diagram, page 5. (*2)		
Transmission cable		Capture cable w/external shield (VCTF 1.25 mm ² , finished O. D. 8.5 to 12mm) (*3)			
Transmission length		Max.1 km			
Transmission lines	2 wire system		Analog or current pulse		
	3 wire system		Open collector or voltage pulse		
	4 wire system		Analog + current pulse		
Ambient temperature		-10 to +60°C (Explosionproof model: -10 to +55°C) (Without dew condensation)			
Explosionproof configuration		Select either one from following two ① Non-explosionproof type ⑤ FM Class I, Division I / Group C, D T4 ② TIIS Exd IIB T4 / Exia IIB T4, Exia IIB T3 (*6) AEx / Exd IIB T4 ③ NEPSI Exd IIB T4 ⑥ KOSHA Exd IIB T4 ④ ATEX II 2G Exd IIB T4			
Applicable EU directive		EMC 2004 / 108 / EC ATEX 94 / 9 / EC (*8) PED 97 / 23 / EC (*9)			
Applicable EN standard		EMC EN55011 : 1998 / A1 : 1999 Group 1, Class B EN61000-6-2 : 1999 ATEX EN60079-0 : 2006, EN60079-1 : 2007			
Degree of Protection for enclosure		IP66 (Dust-tight/Watertight Type) - IEC/EN60529, JIS C 0920			
Material for housing		Aluminum die casting			
Finish		Munsell No. 2.5PB5/8 baked			

*1 : If factored pulse units other than above are required, consult the factory.

*2 : Battery powered register features a local indicator alone; output signal is not available.

*3 : For wiring of explosionproof type, do not fail to use the ancillary pressure-resistant packing.

Register Model UA; In case of TIIS explosionproof type used under the ambient temperature of 45°C or higher, use a cable resistant to the temperature of 75°C or higher.

Register Model UD; In case of TIIS explosionproof type used under the ambient temperature of 40°C or higher, use a cable resistant to the temperature of 80°C or higher.

*4 : Under certain circumstances, the max. flowrate may have limitations if the minimum factored pulse unit is chosen and the pulse width exceeds 1 msec. If this problem arises, consult the factory.

*5 : If the minimum factored pulse unit is chosen with the capacity indicated by an asterisk *, pulse width other than 1 ms is NOT selectable.

*6 : Code 6 shows explosionproof configuration of ULTRA OVAL register with batch control function.

*7 : Details as 94/9/EC compliant explosionproof equipment

Applicable hazardous area	Zone 1 and Zone 2
---------------------------	-------------------

*8 : The compliance with 97/23/EC (Pressure Equipment Directive) differs depending on the conditions of use. For details, contact OVAL representative.

● Nominal Meter Factors

Meter size	Nominal meter factor (mL/P)	Freq. at max. flowrate (Hz)	Max. flowrate (m ³ /h)	P/r
80	250.6	133.0	120	6
81	279.0	179.2	180	10
82	486.8	171.2	300	12
83	803.8	141.7	410	12
84	1389.6	117.9	590	12
85	2842.1	92.9	950	12
86	5190.9	74.9	1400	12
87	8752.2	63.5	2000	12
88	15441.3	50.4	2800	12

■ FLOW RANGE

● Linearity : ±0.15% (Operating temp. range: -5 to +120°C)

Unit in m³/h

Meter Size	Nom. Size mm	Operating Condition	Viscosity (mPa·s)								
			0.3 to 2		2 to 5	5 to 15	15 to 50	50 to 400	400 to 1000	1000 to 1500	1500 to 2000
			Gasoline	Kerosene	Gas oil	Fuel oil A	Fuel oil B	Fuel oil C	High Viscosity Liquid		
80	100 ▲80	Continuous	20 to 77	15 to 77	12 to 100	8 to 100	6 to 100	5 to 100	5 to 55	5 to 45	5 to 39
		Intermittent	20 to 110	15 to 110	12 to 120	8 to 120	6 to 120	5 to 120	5 to 65	5 to 53	5 to 47
81	100	Continuous	28 to 110	20 to 110	17 to 150	15 to 150	8.5 to 150	7 to 150	7 to 80	7 to 63	7 to 55
		Intermittent	28 to 160	20 to 160	17 to 180	15 to 180	8.5 to 180	7 to 180	7 to 95	7 to 75	7 to 65
82	150 ▲100	Continuous	50 to 180	40 to 180	30 to 250	20 to 250	14 to 250	12 to 250	12 to 130	12 to 110	12 to 97
		Intermittent	50 to 270	40 to 270	30 to 300	20 to 300	14 to 300	12 to 300	12 to 160	12 to 130	12 to 115
83	200 ▲150	Continuous	70 to 260	50 to 260	40 to 340	30 to 340	20 to 340	16 to 340	16 to 190	16 to 160	16 to 140
		Intermittent	70 to 380	50 to 380	40 to 410	30 to 410	20 to 410	16 to 410	16 to 230	16 to 190	16 to 165
84	250 ▲200	Continuous	100 to 380	80 to 380	60 to 500	50 to 500	40 to 500	30 to 500	30 to 280	30 to 220	30 to 200
		Intermittent	100 to 550	80 to 550	60 to 590	50 to 590	40 to 590	30 to 590	30 to 330	30 to 270	30 to 240
85	300 ▲250	Continuous	200 to 630	160 to 630	120 to 800	90 to 800	70 to 800	50 to 800	50 to 460	50 to 380	50 to 340
		Intermittent	200 to 900	160 to 900	120 to 950	90 to 950	70 to 950	50 to 950	50 to 550	50 to 450	50 to 400
86	350 ▲300	Continuous	300 to 980	240 to 950	200 to 1100	150 to 1100	100 to 1100	70 to 1100	70 to 720	70 to 590	70 to 520
		Intermittent	300 to 1400	240 to 1400	200 to 1400	150 to 1400	100 to 1400	70 to 1400	70 to 850	70 to 700	70 to 620
87	400 ▲350	Continuous	460 to 1400	370 to 1400	300 to 1700	230 to 1700	180 to 1700	120 to 1700	120 to 970	120 to 800	120 to 700
		Intermittent	460 to 2000	370 to 2000	300 to 2000	230 to 2000	180 to 2000	120 to 2000	120 to 1150	120 to 950	120 to 830
88	450 ▲400	Continuous	700 to 1900	560 to 1900	460 to 2300	350 to 2300	280 to 2300	200 to 2300	200 to 1400	200 to 1100	200 to 1000
		Intermittent	700 to 2800	560 to 2800	460 to 2800	350 to 2800	280 to 2800	200 to 2800	200 to 1700	200 to 1400	200 to 1230

▲ : Special

● Linearity : ±0.35% (Operating temp. range: -5 to +120°C)

Unit in m³/h

Meter Size	Nom. Size mm	Operating Condition	Viscosity (mPa·s)									
			0.3	0.3 to 2		2 to 5	5 to 15	15 to 50	50 to 400	400 to 1000	1000 to 1500	1500 to 2000
			LPG	Gasoline	Kerosene	Gas oil	Fuel oil A	Fuel oil B	Fuel oil C	High Viscosity Liquid		
82	150 ▲100	Continuous	50 to 180	35 to 180	25 to 180	20 to 250	17 to 250	10 to 250	8.5 to 250	8.5 to 130	8.5 to 110	8.5 to 97
		Intermittent	50 to 270	35 to 270	25 to 270	20 to 300	17 to 300	10 to 300	8.5 to 300	8.5 to 160	8.5 to 130	8.5 to 115
83	200 ▲150	Continuous	70 to 260	50 to 260	40 to 260	30 to 340	20 to 340	17 to 340	12 to 340	12 to 190	12 to 160	12 to 140
		Intermittent	70 to 380	50 to 380	40 to 380	30 to 410	20 to 410	17 to 410	12 to 410	12 to 230	12 to 190	16 to 165
84	250 ▲200	Continuous	100 to 380	70 to 380	55 to 380	45 to 500	35 to 500	30 to 500	25 to 500	25 to 280	25 to 220	25 to 200
		Intermittent	100 to 550	70 to 550	55 to 550	45 to 590	35 to 590	30 to 590	25 to 590	25 to 330	25 to 270	25 to 240
85	300 ▲250	Continuous	200 to 630	140 to 630	110 to 630	90 to 800	70 to 800	55 to 800	45 to 800	45 to 460	45 to 380	45 to 340
		Intermittent	200 to 900	140 to 900	110 to 900	90 to 950	70 to 950	55 to 950	45 to 950	45 to 550	45 to 450	45 to 400
86	350 ▲300	Continuous	300 to 980	210 to 980	170 to 980	140 to 1100	110 to 1100	90 to 1100	65 to 1100	65 to 720	65 to 590	65 to 520
		Intermittent	300 to 1400	210 to 1400	170 to 1400	140 to 1400	110 to 1400	90 to 1400	65 to 1400	65 to 850	65 to 700	65 to 620
87	400 ▲350	Continuous	460 to 1400	320 to 1400	260 to 1400	210 to 1700	160 to 1700	140 to 1700	110 to 1700	110 to 970	110 to 800	110 to 700
		Intermittent	460 to 2000	320 to 2000	260 to 2000	210 to 2000	160 to 2000	140 to 2000	110 to 2000	110 to 1150	110 to 950	110 to 830
88	450 ▲400	Continuous	700 to 1900	490 to 1900	400 to 1900	320 to 2300	250 to 2300	210 to 2300	170 to 2300	170 to 1400	170 to 1100	170 to 1000
		Intermittent	700 to 2800	490 to 2800	400 to 2800	320 to 2800	250 to 2800	210 to 2800	170 to 2800	170 to 1700	170 to 1400	170 to 1230

▲ : Special

■ METER ERRORS and PESSURE LOSSES

Meter sizes : 80,81

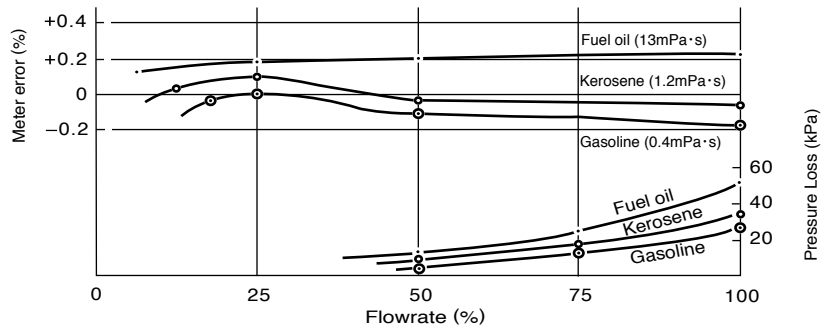

Meter sizes : 82, 83, 84

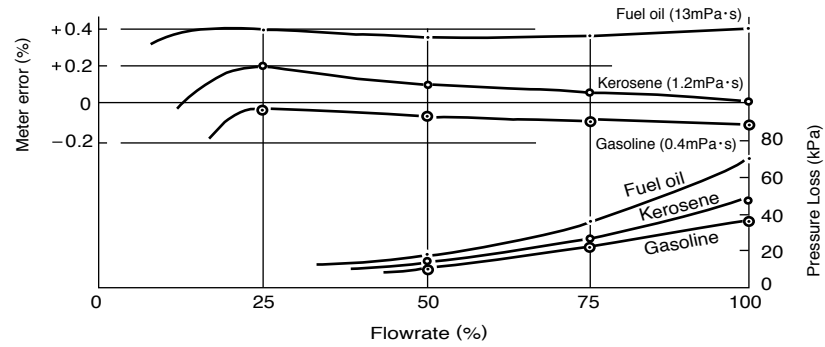

Meter sizes : 85, 86, 87, 88

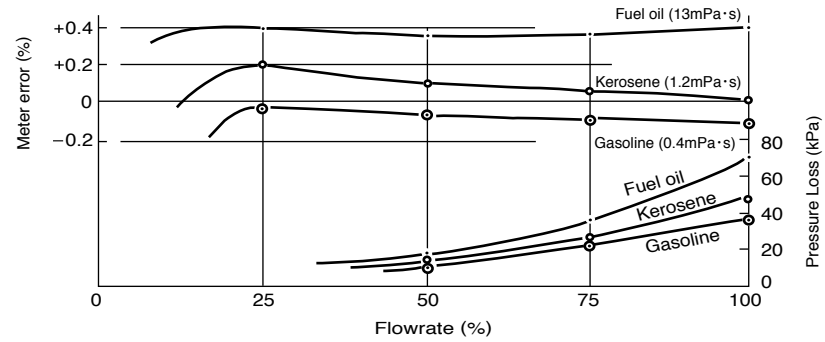

■ HOOKUP WITH RECEIVING INSTRUMENTS

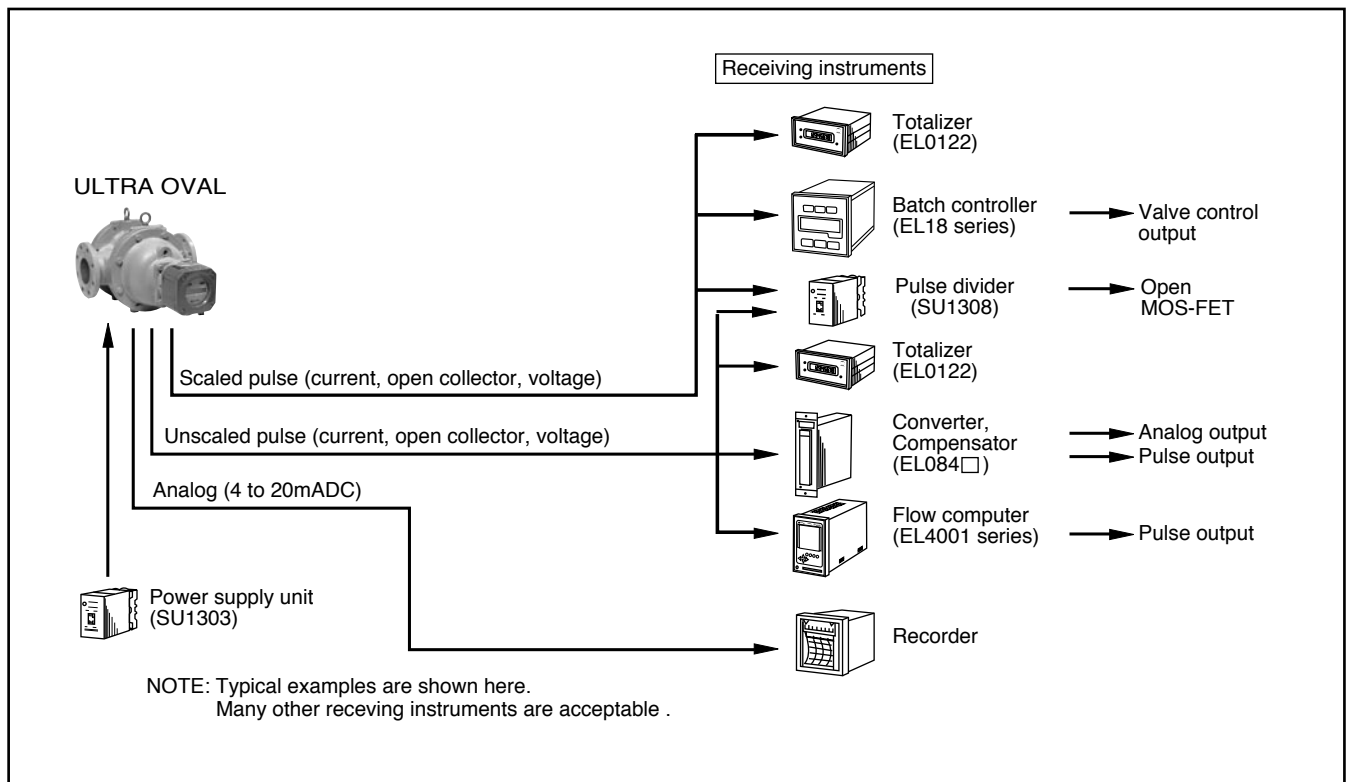

■ WIRING CONNECTIONS

(1) Current pulse output (2 wires)

Oval receiving instruments Oval receiving instruments

NOTE: Oval offers two circuit configurations to accept current pulses as shown above. See the respective instruction manual of receiving instrument for correct connections.

(2) Analog output (2 wires)

In case of current input

NOTE: To accept a voltage signal, couple an external load resistor (see acceptable load resistance range).

(3) Current pulse and Analog output (4 wire system)

NOTE 1: In an Oval receiving instrument, an internal load resistor plays the role of I/V conversion. But if you build a system like the one shown here with a commercially available totalizer, a combination 4/20mA x load resistance serves as a current pulse/voltage pulse converter, make sure of the input level of the totalizer before use.

NOTE 2: With a configuration like the one shown here where an OVAL receiving instrument is used, make sure of the current carrying capacity of receiving instrument's power supply before use. If found inadequate in current carrying capacity, prepare an additional power supply for the analog indicator.

※: Select voltage signal input for the totalizer. Make sure of the trigger level of incoming voltage signal and determine the supply voltage and load resistance value.

(4) Open collector pulse (3 wire system)

(5) Voltage pulse (3 wire system)

● Range of Load Resistance (for current pulse and analog output)

This instrument uses a two-wire transmission line for analog and pulse signals, so the line serves for both power supply and signal. A DC power supply is required for transmission loop. When connecting a meter to the loop, ensure that the meter and the load resistance of cable conductor is within the operating limits shown in the figure at right.

Standard: Power supply voltage=24VDC
Load resistance=250Ω

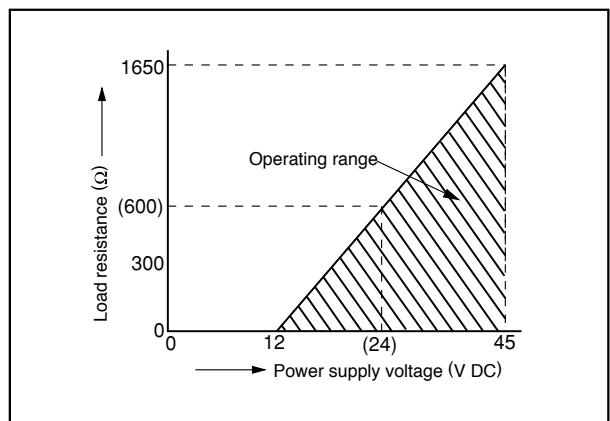

■ PRODUCT CODE EXPLANATION

Item	Code No.															Description	
	①	②	③	④	⑤	⑥	⑦	⑧	⑨	⑩	⑪	⑫	⑬	⑭	⑮		
Type	L															Flowmeter for Liquid service	
	K															Standard oil meter	
Material of Metering Element	B															FC250 (cast iron)	
	R															FC250 + surface treatment (Applicable only to white petroleum products : Gasoline, kerosene, Gas oil)	
Meter size																Large size	Small size
	8 0															Nominal size 100mm (4")	Nominal size 80mm (3") [Special]
	8 1															100mm (4")	_____
	8 2															150mm (6")	100mm (4") [Special]
	8 3															200mm (8")	150mm (6") [Special]
	8 4															250mm (10")	200mm (8") [Special]
	8 5															300mm (12")	250mm (10") [Special]
	8 6															350mm (14")	300mm (12") [Special]
	8 7															400mm (16")	350mm (14") [Special]
8 8															450mm (18")	400mm (16") [Special]	
Meter construction	3	—														Small size Type [Special]	
	4	—														Large size Type	
Register type																U A	Basic ULTRA model
																U B	Batch controller equipped ULTRA register (LW76E) (*1)
																U D	Auto temperature compensator equipped ULTRA register (*2)
Heat radiation adapter																0 —	Not mounted
Body material																F	SCPH2 (Cast steel)
Pressure rating																1	10K (Meter size : 80, 81)
																2	20K (Meter size : 82 to 88)
Bearing type																1	Carbon bearing
Transmission type																5 —	ULTRA register coupled
Register configuration																3	Non-explosionproof
																4	TIIS explosionproof
																5	ATEX explosionproof (*3)
																6	FM explosionproof (*3)
																7	NEPSI explosionproof
																8	KOSHA explosionproof (*3)
Types of output signal (Register case UA only.)																0 0	No output signal, Local LCD only (w/battery unit)
																0 1	Unscaled pulse (Current pulse) 2 wires
																0 2	Scaled pulse (Current pulse) 2 wires
																0 5	Unscaled pulse (Open collector pulse) 3 wires
																0 6	Scaled pulse (Open collector pulse) 3 wires
																0 7	Unscaled pulse (Voltage pulse) 3 wires
																0 8	Scaled pulse (Voltage pulse) 3 wires
																1 0	Analog 2 wires
																1 1	Analog + Unscaled pulse (Current pulse) 4 wires
																1 2	Analog + Scaled pulse (Current pulse) 4 wires
Batch control metering function (Only register type UB.)																7 6	Pneumatic batch controller (LW76E register)
																	2-step open/2-step close type

*1 : For register code UB, see General Specification (No. GBC201E).
 *2 : For register code UD, consult the factory.
 *3 : Applicable only to "Standard Ultra register" type.

■ **OUTLINE DIMENSIONS (In standard register type UA provided) [Unit in mm]**

● **Meter sizes : 80, 81**

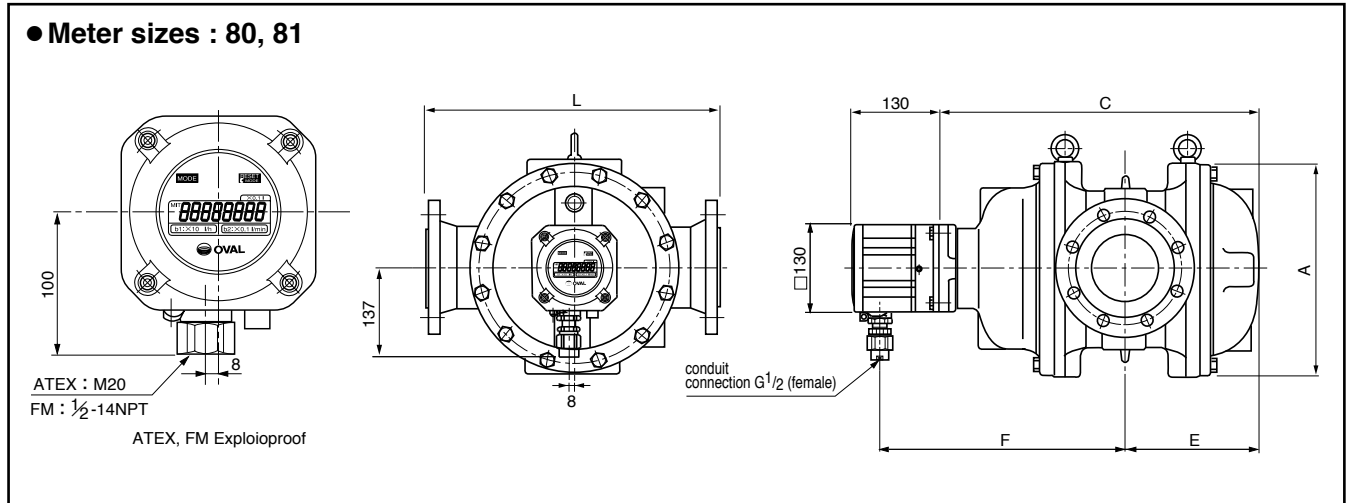

Meter Size	Nominal Size mm	Dimensions Flange Rating	L		A	C	F	E	Approx. Weight	
			FC Body	SCPH2 Body					FC Body	SCPH2 Body
80	100 (4")	JIS 10K	380	380	284	436	346	178	90kg	96kg
		ASME 125	380	—						
		ASME/JPI150	—	380						
	80 (3") Special	JIS 10K	380	380						
		ASME 125	380	—						
		ASME/JPI150	380	380						
81	100 (4")	JIS 10K	440	440	324	484	369	203	130kg	135kg
		ASME 125	440	—						
		ASME/JPI150	—	440						

Note: 1. For batch controller equipped ULTRA register, refer to General Specification (No.GBC201E).
2. For models provided with auto temperature compensator equipped ULTRA register, consult the factory.

● **Meter sizes : 82, 83, 84**

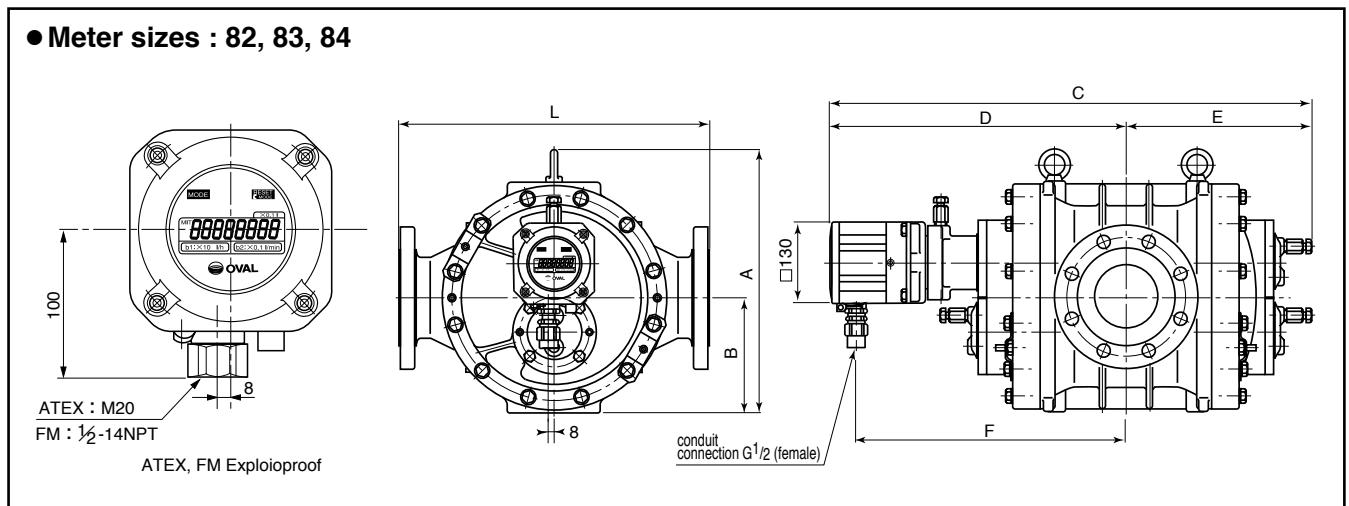

Meter Size	Nominal Size mm	Dimensions Flange Rating	L	A	B	C	D	E	F	Approx. Weight
83	200 (8") ▲150 (6")	ASME/JPI 150 RF	550	480	185	835	509	326	467	310kg 300kg
	250 (10") ▲200 (8")		700	571	185	918.5	548.5	370	506.5	435kg 425kg

Note: 1.For batch controller equipped ULTRA register, refer to General Specification (No.GBC201E).
2.For models provided with auto temperature compensator equipped ULTRA register, consult the factory. ▲ : Special

■ OUTLINE DIMENSIONS (In standard register type UA provided) [Unit in mm]

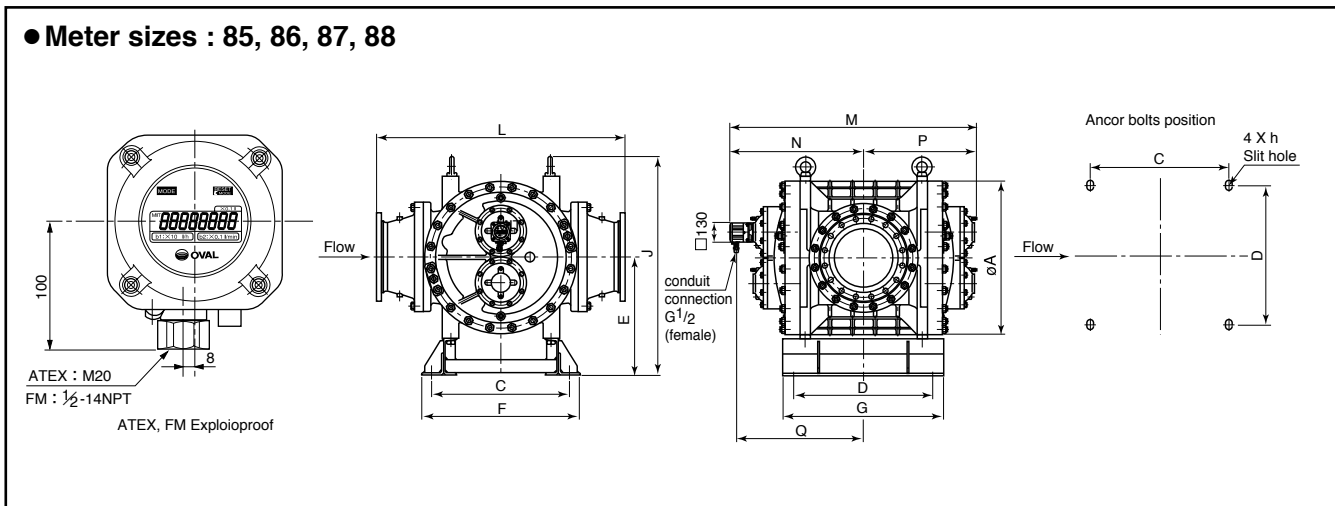

Meter Size	Nominal Size mm	Flange Rating	Dimensions													Approx. Weight
			L	φA	J	E	M	N	P	Q	C	D	F	G	h	
85	300 (12")	JIS 10K RF	1000	630	1050	580	1094	624	470	582	640	550	760	700	φ30×50	1250kg
	▲250 (10")		1200	740	1090	600	1205.5	684	525	642	700	650	820	800	φ36×56	1200kg
86	350 (14")	JIS 20K RF	1300	850	1200	645	1387	771	613	729	780	700	900	850	φ36×56	1530kg
	▲300 (12")		1700	1040	1482	800	1684	914	770	872	950	950	1080	1100	φ42×62	1500kg
87	400 (16")	ASME/JPI 150 RF	1300	850	1200	645	1387	771	613	729	780	700	900	850	φ36×56	2500kg
	▲350 (14")		1700	1040	1482	800	1684	914	770	872	950	950	1080	1100	φ42×62	2200kg
88	450 (18")	ASME/JPI 150 RF	1700	1040	1482	800	1684	914	770	872	950	950	1080	1100	φ42×62	4600kg
	▲400 (16")		1700	1040	1482	800	1684	914	770	872	950	950	1080	1100	φ42×62	3800kg

Note: 1.For batch controller equipped ULTRA register, refer to General Specification (No.GBC201E).
2.For models provided with auto temperature compensator equipped ULTRA register, consult the factory. ▲ : Special

■ OPERATING PRECAUTIONS

This flowmeter is not provided with subtract function. If pulsation in the flow (where the fluid moves back and forth in the pipeline under the influence of pressure) or reversal of flow exists, the total counter may show erratic reading, accumulating all incoming pulses irrespective of flow direction.

■ PLEASE SUPPLY THE FOLLOWING INFORMATION WHEN YOU INQUIRE.

1. Model	L _____
2. Fluid to be measured	Name _____ Viscosity _____ mPa·s Specific gravity _____
3. Flowrate (m ³ /h)	Maximum _____ Normal _____ Minimum _____
4. Fluid temperature (°C)	Maximum _____ Normal _____ Minimum _____
5. Ambient temperature (°C)	Maximum _____ Normal _____ Minimum _____
6. Pressure (MPa)	Maximum _____ Normal _____ Minimum _____
7. Flow direction	Right ↔ Left, Bottom ↔ Top
8. Flange connection	Nominal size _____ mm, Flange rating _____
9. Required Linearity	± _____ %
10. Explosionproof configuration	<input type="checkbox"/> Required class _____ <input type="checkbox"/> Not required
11. Accessories	<input type="checkbox"/> Strainer <input type="checkbox"/> Air eliminator, <input type="checkbox"/> Companion flange
12. Quantity	Including accessories _____
13. Receiving instrument	Type, manufacturer, model, specifications (input, output, power supply, etc.)
14. Distance between flow meter and receiving instrument	_____ m

The specification as of Mar., 2013 is stated in this GS Sheet. Specifications and design are subject to change without notice.

Sales Representative: