

MODEL SJ-900 SWING CHECK VALVE

The **Shurjoint** Model SJ-900 Swing Check Valve is a grooved-end check valve featuring a spring-loaded wide-open clapper and a non-stick leak tight EPDM rubber seal. With a rated working pressure of 300 psi (20 bar), the valve can be installed in the horizontal or vertical position (upward flow only). Valves are tested to API 598.

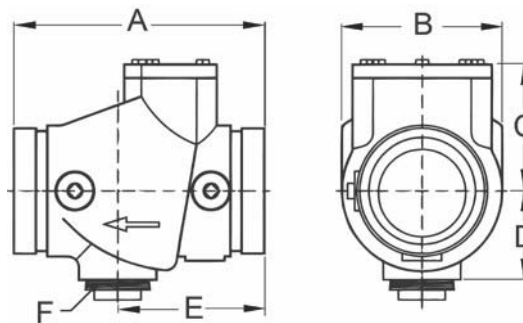

Important Note: The placement of check valves too close to sources of unstable flows may damage the system and reduce valve life. Sound piping practices dictate check valves should always be installed a minimum of five (5) times the pipe diameter downstream from pumps, reducers, elbows and the like. Distances between three (3) and five (5) times are allowable when flow velocity does not exceed eight (8) feet per second (2.4 mps). Distances less than three diameters are not recommended and will void any warranty.



Model SJ-900 Swing Check Valve									
Nominal Size	Pipe O.D.	Max. Working Pressure (CWP)*	Dimensions						
			A	B	C	D	E	F	Weight
in	in	PSI	in	in	in	in	in	in	Drain
mm	mm	Bar	mm	mm	mm	mm	mm	mm	Lbs
2½	2.875	300	7.48	4.50	3.75	2.50	4.00	11¼"	11.0
65	73.0	20	190	114	95	64	102	NPT	5.0
76.1 mm	3.000	300	7.48	4.50	3.75	2.50	4.00	1¼"	10.8
	76.1	20	190	114	95	64	102	BSP	4.9
3	3.500	300	7.00	4.50	3.75	2.50	4.00	1¼"	10.8
80	88.9	20	178	114	95	64	102	NPT	4.9
4	4.500	300	8.50	5.75	4.60	3.15	5.00	2"	18.3
100	114.3	20	216	146	117	80	127	NPT	8.3
139.7 mm	5.500	300	13.00	8.58	7.00	4.50	7.64	2"	51.7
	139.7	20	330	218	178	114	194	BSP	23.5
5	5.563	300	13.00	8.58	7.00	4.50	7.64	2"	51.7
125	141.3	20	330	218	178	114	194	NPT	23.5
165.1 mm	6.500	300	12.00	8.25	7.00	4.50	7.00	2"	51.7
	165.1	20	305	210	178	114	178	BSP	23.5
6	6.625	300	12.00	8.25	7.05	4.50	7.00	2"	51.7
150	168.3	20	305	210	178	114	178	NPT	23.5
8	8.625	300	14.37	10.47	8.54	5.50	10.00	2"	99.7
200	219.1	20	365	266	217	140	254	NPT	45.3
10	10.750	300	20.00	14.37	10.75	7.25	10.00	2"	217.8
250	273.0	20	508	365	273	184	254	NPT	99.0
12	12.750	300	24.00	15.51	12.87	8.54	12.00	2"	342.3
300	323.9	20	610	394	327	217	305	NPT	155.6
200 JIS	8.516	300	14.37	10.47	8.54	5.50	10.00	2"	99.7
	216.3	20	365	266	217	140	254	BSP	45.3
250 JIS	10.528	300	20.00	14.37	10.75	7.25	10.00	2"	216.7
	267.4	20	508	365	273	184	254	BSP	98.5
300 JIS	12.539	300	24.00	15.51	12.87	8.54	12.00	2"	342.3
	318.5	20	610	394	327	217	305	BSP	155.6

*Working pressure is based on connection with roll- or cut-grooved standard wall carbon steel pipe.

Flow Data

Equivalent Length of Sch. 40 pipe

Model SJ-900 Swing Check Valve					
Valve Size	Actual O.D.	Equivalent Length	Valve Size	Actual O.D.	Equivalent Length
in	in	feet	in	in	feet
mm	mm	meter	mm	mm	meter
2½	2.875	7.0	6	6.625	24.0
65	73.0	2.1	150	168.3	7.3
3	3.500	15.0	8	8.625	38.0
80	88.9	4.6	200	219.1	11.6
4	4.500	24.0	10	10.750	65.0
100	114.3	7.3	250	273.0	19.8
5	5.563	24.0	12	12.750	85.0
125	141.3	7.3	300	323.9	25.9

MATERIAL SPECIFICATIONS

- **Valve Body & Bonnet:**

Ductile Iron to ASTM A536, Gr. 65-45-12 and or to ASTM A395, Gr. 65-45-15, min. tensile strength 65,000 psi (448 MPa).

- **Surface Finish:**

Painted Black.
 Epoxy Coated Black.

- **Clapper:**

Stainless steel Type 304 of ASTM A240 (2½" – 4"),
 Ductile iron ASTM A536 Gr. 65-45-12 (5" – 12").

- **Clapper Facing:**

Grade "E" EPDM to ASTM D2000. Good for cold & hot water up to +180°F (+82°C). Also good for services for water with acid, water with chlorine, deionized water, seawater and waste water, dilute acids, oil-free air and many chemicals.

Not recommended for petroleum oils, minerals oils, solvents and aromatic hydrocarbons.

- **Seat Ring:**

Bronze C83600 of ASTM B505.

- **Facing Retainer, Cap Screw, Lock Nuts:**

Stainless steel Type 304.

- **Hinge Pin:**

Stainless steel Type 303 of ASTM A582.

- **Spring:**

Stainless steel Type 302 of ASTM A313.

- **Set Screw:**

Heat-treated carbon steel hexagonal set screw to ASTM A183, Gr. 2, minimum tensile strength 110,000 psi (758 MPa).

General Notes:

- **Maximum Working Pressure (CWP)** listed is the maximum cold water pressure for general piping services tested to ASTM F1476 and or AWWA C606 methods. Figures listed are based on roll- or cut-grooved standard wall carbon steel pipe. For other pipe schedules or pipe materials, contact **Shurjoint** for additional information.
- **Field Joint Test:** For one time only the system may be tested hydrostatically at 1½ times the maximum working pressure listed (AWWA C606 5.2.3).
- **Warning:** Piping systems must always be depressurized and drained before attempting disassembly and or removal of any components.
- **The 10 Year Limited Warranty** applies to manufacturing defects only and does not cover severe service/temperature applications or wear parts.
- **Shurjoint** reserves the right to change specifications, designs and or standard without notice and without incurring any obligations.