

# TOTAL CONTROL SYSTEMS

*"The Standard of Measurement"*

---

## MODEL 682

---

### PISTON POSITIVE DISPLACEMENT FLOW METER



TCS Model 682-15-SP-L-10

Distributed By:

The TCS model 682 series positive displacement reciprocating piston flow meter is designed to accurately measure liquids within the Petroleum, Chemical, Food Processing, Agricultural, and other industries requiring precise liquid flow measurement.

## DESIGN FEATURES

The TCS model 682 series flow meter is a true positive displacement meter that has a unique inline design consisting of three reciprocating pistons operating within their respective measuring chambers, where each piston works in a manner similar to an automobile engine. The pistons are fitted to a wobble plate, which has a shaft extending from its upper surface and a valve pivot attached beneath it. The valve pivot drives a sliding valve from piston to piston as a known amount of product flows through each cylindrical bore, controlling the sequence of events in a smooth mechanical motion. This smooth mechanical motion is then transferred through the calibrator to the register.

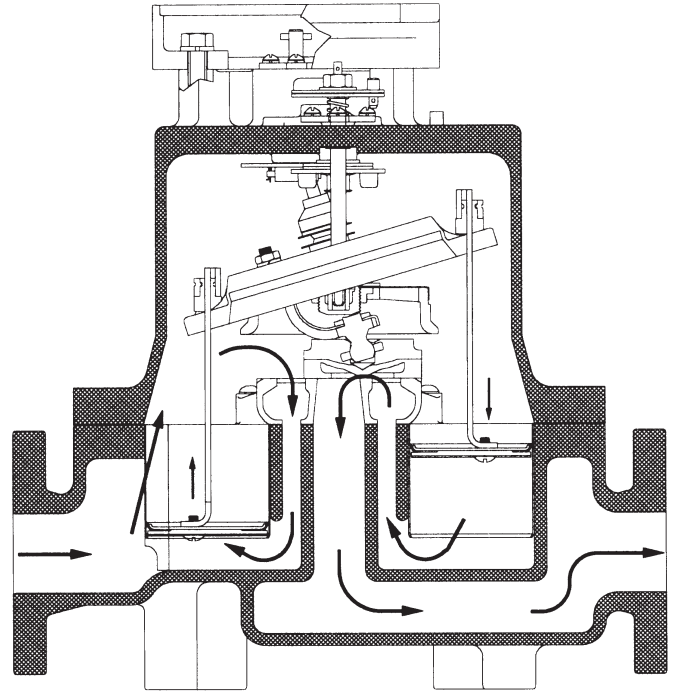

## ACCURACY AND FLOW RATE

The TCS model 682 series flow meter combines outstanding accuracy ( $\pm 0.1\%$  of flow rate) with an exceptionally wide turndown ratio (200:1). At constant flow, with all other conditions being constant, the flow meter does not vary more than  $\pm 0.025\%$  in repeatability. This superior performance is supported by the National Type Evaluation Program (NTEP) Certificate of Conformance meeting the National Institute of Standards and Technology (NIST) Handbook 44 requirements and the Canadian Weights & Measures Sections 14 & 15 regulations. The TCS model 682 series flow meter is virtually unaffected by changing viscosities. The inline meter design allows the TCS model 682 series flow meter to have a wide operating range (0.2 to 40 GPM) and fluid compatibility that has been proven over many years of service.

## FEATURES

- Excellent accuracy
- Wide turndown ratio 200:1. A perfect choice for slow flow measurement and batching applications
- High tolerance to changing viscosity
- Wide range of flow - 0.2 GPM to 40 GPM
- Wide operating temperature
- Wide fluid compatibility range
- Industrial-grade construction
- Proven design and reputation

## METER TYPES

SP - Standard Petroleum

Petroleum base products: Gasoline, Fuel Oil, Jet Fuel, Kerosene, Lubricating Oil, etc.

AF - All Ferrous

Petroleum base products, Industrial Chemicals, Agricultural products.

SS - Stainless Steel

Covers the same products as the SP and AF models but includes special handling liquids; such as Acids.

## METER CONSTRUCTION

Model 682SP

Outer Housing  
Internals  
Cups  
Seals

Cast Iron  
Iron, Steel, and Stainless Steel  
Glass-filled TFE  
Synthetic Rubber

Model 682AF

Outer Housing  
Internals  
Cups  
Seals

Cast Iron  
Cast Iron and Stainless Steel  
Glass-filled TFE  
Teflon® Gaskets or Teflon® O-rings

Model 682SS

Outer Housing  
Internals  
Cups  
Seals

316 Stainless Steel  
316 Stainless Steel  
Glass-filled TFE  
Teflon® Gaskets or Teflon® O-rings

## METER SPECIFICATIONS

Type	Reciprocating 3 Piston Positive Displacement
Connections	1½ inch flange
Flow Range	Minimum: 0.2 GPM (.76 LPM) Maximum: 40 GPM (151 LPM)
Working Pressure	150 PSI (10.5 Bar)
Working Temperature	Model 682SP: -20°F to 200°F (-28.9°C to 93.3°C) Models 682AF and 682SS: 20°F to 400°F (-28.9°C to 204.4°C)
Turndown Ratio	200:1
Enclosure Class	Totally mechanical; if equipped with a pulse transmitter, the rating of the pulsing device applies
Units of Measure	U.S. Gallons, STANDARD Liters, pounds, etc. available upon request

*Teflon® is a registered trademark of DuPont.*

# TCS MODEL 682 SERIES FLOW METER OPTIONS

Register	Veeder Root 5 wheel resetable with totalizer (9999.9)
Preset	Veeder Root 5-digit (4 whole units, plus 1 tenths 9999.9)
Ticket Printer	Veeder Root Zero Start (Standard)
Shut-off Valve	Available with Veeder Root Preset Register. Appropriate internals, gaskets, and seals to each model. Note: 2 stage valve closure.
Cutoff Switch	Available with 2 stage Veeder Root Preset Register.
Temperature Compensator	Veeder Root
Transmitter Type	Veeder Root
Transmitter Output	1, 10 or 100 pulses per revolution of output shaft.
Air Eliminator	Available with the appropriate internals, gaskets, and seals to each model.

# TCS MODEL 682 SERIES FLOW METER DESCRIPTIONS

Description	Standard Petroleum (SP)	All Ferrous (AF)	316 Stainless Steel (SS)
	Model Number Approx. Weight	Model Number Approx. Weight	Model Number Approx. Weight
Meter	682-15-SP-L-1 96 lbs.	682-15-AF-L-1 96 lbs.	682-15-SS-L-1 98 lbs.
Meter and register	682-15-SP-L-2 110 lbs.	682-15-AF-L-2 110 lbs.	682-15-SS-L-2 112 lbs.
Meter, register, and printer	682-15-SP-L-3 119 lbs.	682-15-AF-L-3 119 lbs.	682-15-SS-L-3 121 lbs.
Meter, register, and air eliminator	682-15-SP-L-4 171 lbs.	682-15-AF-L-4 171 lbs.	682-15-SS-L-4 179 lbs.
Meter, register, printer, and air eliminator	682-15-SP-L-6 180 lbs.	682-15-AF-L-6 180 lbs.	682-15-SS-L-6 188 lbs.
Meter, register, preset, and valve RIGHT HAND FLOW	682-15-SP-L-8 146 lbs.	682-15-AF-L-8 146 lbs.	682-15-SS-L-8 150 lbs.
Meter, register, printer, preset, and valve RIGHT HAND FLOW	682-15-SP-L-9 155 lbs.	682-15-AF-L-9 155 lbs.	682-15-SS-L-9 159 lbs.
Meter, register, preset, valve, and air eliminator RIGHT HAND FLOW	682-15-SP-L-10 207 lbs.	682-15-AF-L-10 207 lbs.	682-15-SS-L-10 217 lbs.
Meter, register, printer, preset, valve, and air eliminator RIGHT HAND FLOW	682-15-SP-L-11 216 lbs.	682-15-AF-L-11 216 lbs.	682-15-SS-L-11 226 lbs.

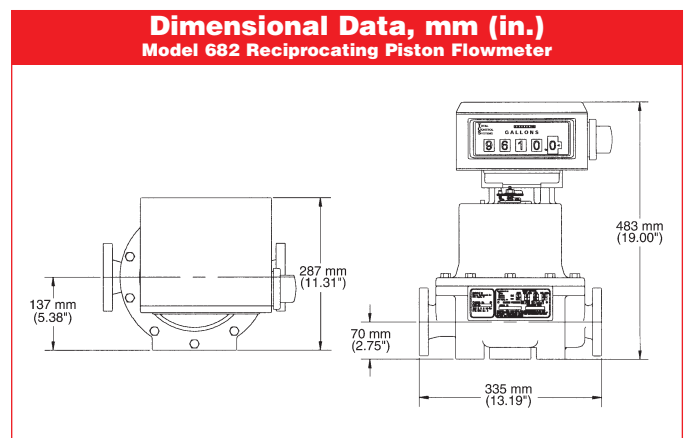
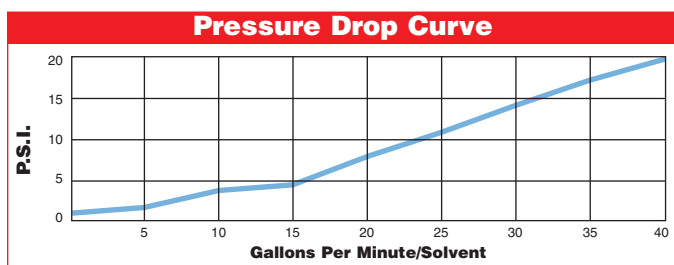
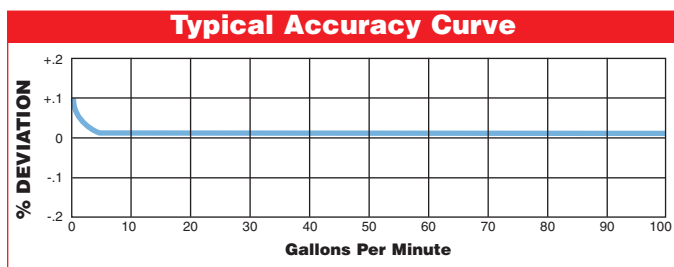

Total Control Systems  
2515 Charleston Place • Fort Wayne, IN 46808  
www.tesmeters.com • 800/348-4753 • 219/484-0382