

Operator's manual

Drive motor M1000, M2000, M3000 for modular internal vibrator HMS



07.2013

5100002951en / 002



Manufacturer

Wacker Neuson Produktion GmbH & Co. KG

Preußenstraße 41

80809 München

www.wackerneuson.com

Tel.: +49-(0)89-354 02-0

Fax: +49-(0)89-354 02-390

Translation of the original operator's manual in German



**WACKER
NEUSON**

| | | |
|-----------|--|-----------|
| 1 | Foreword | 5 |
| 2 | Introduction | 6 |
| | 2.1 Means of representation for this operator's manual | 6 |
| | 2.2 Wacker Neuson representative | 7 |
| | 2.3 Described machine types | 7 |
| | 2.4 Identification of the machine | 8 |
| 3 | Safety | 9 |
| | 3.1 Principle | 9 |
| | 3.2 Qualification of the operating personnel | 12 |
| | 3.3 Protective gear | 13 |
| | 3.4 Transport | 14 |
| | 3.5 Operating safety | 14 |
| | 3.6 Safety during the operation of hand machines | 17 |
| | 3.7 Safety during the operation of electric appliances | 17 |
| | 3.8 Safety during the operation of modular internal vibrator | 19 |
| | 3.9 Maintenance | 19 |
| 4 | Safety and information labels | 21 |
| 5 | Scope of delivery | 25 |
| 6 | Structure and function | 26 |
| | 6.1 Application | 26 |
| | 6.2 Field of application | 26 |
| | 6.3 Functionality | 26 |
| 7 | Components and operator's controls | 27 |
| | 7.1 Drive components and operator's controls | 27 |
| | 7.2 Components of the HMS | 28 |
| | 7.3 Flexible shaft components (optional) | 29 |
| | 7.4 Vibrator head components (optional) | 29 |
| 8 | Transport | 30 |
| 9 | Mounting the HMS | 31 |
| | 9.1 Pre-assembly the vibrator head | 31 |
| 10 | Use and operation | 33 |
| | 10.1 Prior to starting the machine | 33 |
| | 10.2 Starting up | 34 |
| | 10.3 Decommissioning | 39 |
| 11 | Maintenance | 41 |
| | 11.1 Maintenance personnel qualifications | 41 |

| | | |
|-----------|--|-----------|
| 11.2 | Maintenance schedule..... | 42 |
| 11.2.1 | Drive motor | 42 |
| 11.2.2 | HMS..... | 42 |
| 11.3 | Maintenance work | 43 |
| 11.3.1 | Clean HMS | 44 |
| 11.3.2 | Drive motor | 45 |
| 11.3.3 | Flexible shaft | 48 |
| 11.3.4 | Vibrator head | 51 |
| 12 | Malfunctions | 54 |
| 13 | Allowable combination | 56 |
| 13.1 | Drive motor – Flexible shafts – Vibrator head | 56 |
| 14 | Disposal | 58 |
| 14.1 | Disposal of waste electrical and electronic equipment..... | 58 |
| 15 | Accessories | 59 |
| 15.1 | Special wrench for flexible shaft..... | 59 |
| 15.2 | Pipe thread seal..... | 59 |
| 15.3 | Special lubricant for flexible shafts | 59 |
| 15.4 | SS-adapter | 59 |
| 15.5 | Carrying belt for the drive motor | 60 |
| 16 | Technical data | 61 |
| 16.1 | Drive motor | 61 |
| 16.2 | E-Flexible shafts (optional) | 62 |
| 16.3 | S-Flexible shafts (optional) | 62 |
| 16.4 | Standard vibrator head (optional) | 63 |
| 16.5 | HA-Vibrator head (optional)..... | 64 |
| 16.6 | Extension cable | 65 |
| 17 | Glossary | 67 |

1 Foreword

This operator's manual contains information and procedures for the safe operation and maintenance of your Wacker Neuson machine. In the interest of your own safety and to prevent accidents, you should carefully read through the safety information, familiarize yourself with it and observe it at all times.

This operator's manual is not a manual for extensive maintenance and repair work. Such work should be carried out by Wacker Neuson service or authorized specialists.

The safety of the operator was one of the most important aspects taken into consideration when this machine was designed. Nevertheless, improper use or incorrect maintenance can pose a risk. Please operate and maintain your Wacker Neuson machine in accordance with the instructions in this operator's manual. Your reward will be troublefree operation and a high degree of availability.

Defective machine parts must be replaced immediately!

Please contact your Wacker Neuson representative if you have any questions concerning operation or maintenance.

All rights reserved, especially reproduction and distribution rights.

Copyright 2013 Wacker Neuson Produktion GmbH & Co. KG

No part of this publication may be reproduced in any form or by any means, electronic or mechanical, including photocopying, without the expressed written permission of Wacker Neuson.

Any type of reproduction, distribution or storage on data media of any type and form not authorized by Wacker Neuson represents an infringement of copyright and will be prosecuted.

We expressly reserve the right to make technical modifications – even without special notice – which aim at further improving our machines or their safety standards.

2 Introduction

2.1 Means of representation for this operator's manual

Warning symbols

This operator's manual contains safety information of the categories: DANGER, WARNING, CAUTION, NOTICE.

They should be followed to prevent danger to life and limb of the operator or damage to equipment and exclude improper service.



DANGER

This warning notice indicates immediate hazards that result in serious injury or even death.

- ▶ Danger can be avoided by the following the actions mentioned.
-



WARNING

This warning notice indicates possible hazards that can result in serious injury or even death.

- ▶ Danger can be avoided by the following the actions mentioned.
-



CAUTION

This warning notice indicates possible hazards that can result in minor injury.

- ▶ Danger can be avoided by the following the actions mentioned.
-

NOTICE

This warning notice indicates possible hazards that can result in material damage.

- ▶ Danger can be avoided by the following the actions mentioned.
-

Notes

Note: Complementary information will be displayed here.

Instructions

- ▶ This symbol indicates there is something for you to do.
- 1. Numbered instructions indicate that you have to carry out something in a defined sequence.
- This symbol is used for lists.

2.2 Wacker Neuson representative

Depending on your country, your Wacker Neuson representative is your Wacker Neuson service, your Wacker Neuson affiliate or your Wacker Neuson dealer.

You can find the addresses in the Internet at www.wackerneuson.com.

The address of the manufacturer is located at the beginning of this operator's manual.

2.3 Described machine types

This operator's manual is valid for different machine types from a product range. Therefore some figures can differ from the actual appearance of your machine. It is also possible that the descriptions include components which are not a part of your machine.

Details for the described machine types can be found in the chapter *Technical data*.

2.4 Identification of the machine

Nameplate data

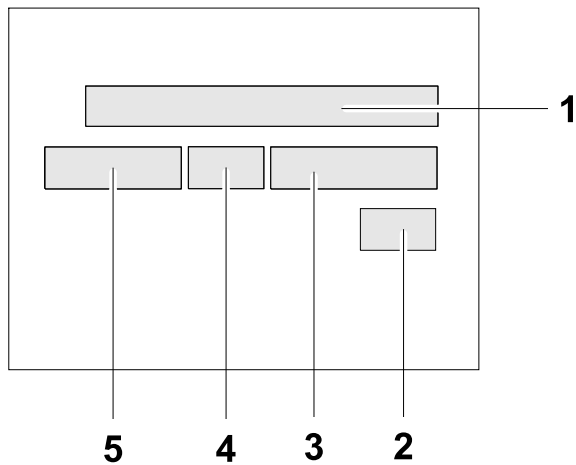

The nameplate lists information that uniquely identifies your machine. This information is needed to order spare parts and when requesting additional technical information.

► Enter the information of your machine into the following table:

| Item | Designation | Your information |
|------|-------------------|------------------|
| 1 | Group and type | |
| 2 | Construction year | |
| 3 | Machine no. | |
| 4 | Version no. | |
| 5 | Item no. | |

3 Safety

3.1 Principle

State of the art

This machine has been constructed with state-of-the-art technology according to the recognized rules of safety. Nevertheless, when used improperly, dangers to the life and limb of the operator or to third persons or damage to the machine or other materials cannot be excluded.

Proper use

The machine may only be used for the operation of flexible shafts and vibrator heads.

The machine may only be combined with allowable components.

The machine may only be operated with allowable flexible shafts and vibrator heads made by Wacker Neuson.

The machine may not be used for the following purposes:

- Connecting non-authorized components.
- Operating without a flexible shaft and vibrator head.

Other special applications must be checked and released by Wacker Neuson.

Its proper use also includes the observance of all instructions contained in this operator's manual as well as complying with the required service and maintenance instructions.

Any other use is regarded as improper. Any damage resulting from improper use will void the warranty and the liability on behalf of the manufacturer. The operator assumes full responsibility.

Structural modifications

Never attempt to modify the machine without the written permission of the manufacturer. To do so will endanger your safety and the safety of other people! In addition, this will void the warranty and the liability on behalf of the manufacturer.

Especially the following are cases of structural modifications:

- Opening the machine and the permanent removal of components from Wacker Neuson.
- Installing new components which are not from Wacker Neuson and not equivalent to the original parts in design and quality.
- Installation of accessories which are not from Wacker Neuson.

It is no problem to install spare parts from Wacker Neuson.

It is no problem to install accessories that are available in the Wacker Neuson product range of your machine. Please refer to the installation regulations in this operator's manual.

Do not drill into the housing, e.g. to install signs. Water could penetrate the housing and damage the machine.

Requirements for operation

The ability to operate the machine safely requires:

- Proper transport, storage and setup.
- Careful operation.
- Careful service and maintenance.

Operation

Operate the machine only as intended and only when in proper working condition.

Operate the machine in a safety-conscious manner with all safety devices attached and enabled. Do not modify or disable any safety devices.

Before starting operation, check that all control and safety devices are functioning properly.

Never operate the machine in a potentially explosive environment.

Supervision

Never leave the machine running unattended!

Maintenance

Regular maintenance work is required in order for the machine to operate properly and reliably over time. Failure to perform adequate maintenance reduces the safety of the machine.

- Strictly observe the prescribed maintenance intervals.
- Do not use the machine if it requires maintenance or repairs.

Malfunctions

If you detect a malfunction, you must shut down and secure the machine immediately.

Eliminate the malfunctions that impair safety immediately!

Have damaged or defective components replaced immediately!

For further information, refer to chapter *Troubleshooting*.

Spare parts, accessories

Use only spare parts from Wacker Neuson or such that are equivalent to the original parts in design and quality.

Only use accessories from Wacker Neuson.

Non-compliance will exempt the manufacturer from all liability.

Exclusion of liability

Wacker Neuson will refuse to accept liability for injuries to persons or for damage to materials in the following cases:

- Structural modifications.
- Improper use.
- Failure to comply with this operator's manual.
- Improper handling.
- Using of spare parts which are not from Wacker Neuson and not equivalent to the original parts in design and quality.
- Using of accessories which are not from Wacker Neuson.

Operator's manual

Always keep the operator's manual near the machine or near the worksite for quick reference.

If you have misplaced the operator's manual or require an additional copy, contact your Wacker Neuson representative or download the operator's manual from the Internet (www.wackerneuson.com).

Always hand over this operator's manual to other operators or to the future owner of the machine.

Country-specific regulations

Observe the country-specific regulations, standards and guidelines in reference to accident prevention and environmental safety, for example those pertaining to hazardous materials and wearing protective gear.

Complement the operator's manual with additional instructions taking into account the operational, regulatory, national or generally applicable safety guidelines.

Operator's controls

Always keep the operator's controls of the machine dry, clean and free of oil or grease.

Operating elements such as ON/OFF switch, gas handles etc. may not be locked, manipulated or changed without authorization.

Checking for signs of damage

Inspect the machine when it is switched off for any signs of damage at least once per work shift.

Do not operate the machine if there is visible damage or defects.

Have any damage or defects eliminated immediately.

3.2 Qualification of the operating personnel

Operator qualifications

Only trained personnel are permitted to start and operate the machine. The following rules also apply:

- You are physically and mentally fit.
- You have received instruction on how to independently operate the machine.
- You have received instruction in the proper use of the machine.
- You are familiar with required safety devices.
- You are authorized to start machines and systems in accordance with the standards governing safety.
- Your company or the operator has assigned you to work independently with this machine.

Incorrect operation

Incorrect operation or misuse by untrained personnel can endanger the health and safety of the operator or third persons and also cause machine and material damage.

Operating company responsibilities

The operating company must make the operator's manual available to the operator and ensure that the operator has read and understood it.

Work recommendations

Please observe the recommendations below:

- Work only if you are in a good physical condition.
- Work attentively, particularly as you finish.
- Do not operate the machine when you are tired.
- Carry out all work calmly, circumspectly and carefully.
- Never operate the machine under the influence of alcohol, drugs or medication. This can impair your vision, reactions and your judgment.
- Work in a manner that does not endanger others.
- Ensure that no persons or animals are within the danger zone.

3.3 Protective gear

Work clothing

Clothing should be appropriate, i.e. should be close-fitting but not restrict your movement.

When on construction sites, do not wear long hair loosely, loose clothing or jewelry including rings. These objects can easily get caught or be drawn in by moving machine parts.

Only wear clothing made of material that is not easily flammable.

Personal protective gear

Wear personal protective gear to avoid injuries or health hazards:

- Non-skid, hard-toed shoes.
- Work gloves made of durable material.
- Overalls made of durable material.
- Hard hat.
- Ear protection.
- Face protection.
- Wear eye protection.

Ear protection

This machine generates noise that exceeds the country-specific permissible noise levels (individual rating level). It may therefore be necessary to wear ear protection. You can find the exact value in the chapter *Technical Data*.

When wearing ear protection while working, you must pay attention and exercise caution because your hearing is limited, e.g. in case someone screams or a signal tone sounds.

Wacker Neuson recommends that you always wear ear protection.

3.4 Transport

Switching off the machine

Before you transport the machine, switch it off and pull the plug out of the plug receptacle. Allow the motor to cool down.

Transporting the machine

Secure the machine on the transport device against tilting, falling or slipping.

Lifting the machine

A falling machine can cause serious injuries.

The machine has no lifting or lashing points.

When lifting the machine, secure it in a closed transport container or similar in order to prevent it from toppling, falling or slipping away.

Restarting

Machines, machine parts, accessories or tools that were detached for transport purposes must be re-mounted and fastened before restarting.

Only operate in accordance with the operating instructions.

3.5 Operating safety

Explosible environment

Never operate the machine in a potentially explosive environment.

Work environment

Familiarize yourself with your work environment before you start work. This includes e.g. the following items:

- Obstacles in the work and traffic area.
- Load-bearing capacity of the ground.
- The measures needed to cordon off the construction site from public traffic in particular.
- The measures needed to secure walls and ceilings.
- Options available in the event of an accident.

Safety in the work area

When working with the machine especially pay attention to the following points:

- Pay maximum attention in the vicinity of drops or slopes. Risk of falling.
- No one may come near the machine during operation.

Checks before starting work atusing the HMS

Check the following points before beginning work:

- Connection value of the machine.
- State of the individual components.
- Allowable combinations and connections of the HMS.

Starting the HMS

Observe the safety information and warning notices located on the drive motor and in the operator's manual.

Never attempt to start a machine that requires maintenance or repairs.

Start up the HMS from the drive motor according to the operator's manual.

Vertical stability

Always make sure that you stand firmly when working with the HMS. This applies particularly when working on scaffoldings, ladders, uneven or slippery floors etc.

Caution with hot parts

Do not touch the hot vibrator head (Components of the HMS) during or shortly after operation. The vibrator head can become very hot and can cause severe burns.

Caution with movable parts of the HMS

Keep your hands, feet and loose clothing away from moving or rotating vibrator head (Components of the HMS).

Do not use components of to HMS for climbing on or holding onto

Never use the protective hose, power cable or other components of the HMS for climbing on or holding onto.

Protecting the flexible shaft (Components of the HMS)

Do not bend or kink the flexible shaft excessively.

Do not drag the flexible shaft over sharp edges.

If the flexible shaft jams in the reinforcement, switch off the drive and disconnect the flexible shaft from the drive. Then free the flexible shaft by carefully moving it back and forth.

Switching off the machine

Switch off the machine and pull the plug out of the plug receptacle in the following situations:

- Before breaks.
- If you are not using the machine.

Before storing the machine, wait until it has completely stopped running.

Store the machine or put it down in such a way that it cannot tilt, fall down or slip.

Storage

Set the machine down or store it securely so that it cannot tilt, fall down or slip.

Storage location

After operation, allow the machine to cool and then store it in a sealed-off, clean and dry location protected against frost and inaccessible to children.

Vibrations of the HMS

When manually operated drive motors are intensively used, long-term damage caused by vibrations cannot be precluded.

Observe the relevant legal instructions and guidelines to minimize vibration stress.

Details on vibration stress associated with the HMS can be found in the chapter *Technical Data*.

3.6 Safety during the operation of hand machines

Safe working with hand machines

While working, always hold the machine on the handle provided.

Setting the hand machine down properly

Set the machine down carefully. Do not drop the machine to the floor or from greater heights. Dropping the machine can cause injuries to other persons or the machine itself can be damaged.

Guide the power cable away from the drive motor to the rear and keep the power cable away from the working range of the vibrator head.

Make sure the air inlets and outlets are unobstructed.

3.7 Safety during the operation of electric appliances

Specific regulations for electrical appliances

Observe the safety information provided in the brochure *General Safety Rules* which is included in the scope of delivery of your machine.

Also observe the country-specific regulations, standards and guidelines in reference to accident prevention in connection with electrical equipment and machines.

⚠ WARNING Read all safety information and all instructions. Failure to follow the safety information and instructions may result in electric shock, fire and/or serious injury.

Save all safety information and instructions for future reference.

Electric power supply for electrical appliances of class rating II

Note: The rated voltage is indicated on the nameplate of your machine.

The machine may only be connected to an electric power supply with all machine parts in proper working condition. Take special notice of the following components:

- Plug.
- Power cable over the entire length.
- Switch diaphragm of the ON/OFF switch, if there is one.
- Plug receptacles.
- GFCI (Fault current protective switch)

Electrical appliances of class rating II have a strengthened or double insulation (protective insulation). They have no connection to the grounded conductor.

There must be at least one of the following safety devices if connected to a stationary or mobile generator:

- Fault current protective switch.
- Isolation (earth leakage) monitor.
- IT-net.

Note: Observe the respective national safety regulations!

Extension cable (Accessories)

The machine may only be operated with undamaged and tested extension cables!

Only use extension cables with grounded conductor and correct connection of the grounded conductor to the plug and coupling (only for machines of class rating I, see chapter *Technical data*).

Only use tested extension cables which are suitable for use at construction sites: Average rubber hose H05RN-F or better – Wacker Neuson recommends H07RN-F, an SOOW cable, or a country-specific equivalent design.

Immediately replace damaged extension cables (e.g. tears in the sheathing) or loose plugs and couplings.

Cable drums and multiple plug receptacles must fulfill the same requirements as the extension cable.

Protect extension cables, multiple plug receptacles, cable drums and connection couplings against rain, snow or any other forms of moisture.

Uncoil the cable drum completely (Accessories)

Danger of fire due to wound cable drum.

Uncoil the cable drum completely before operation.

Protecting the power cable

Do not use the power cable to pull or lift the machine.

Do not unplug the power cable by pulling on the cable.

Protect the power cable from heat, oil and sharp edges.

If the power cable is damaged or the plug is loose, have it replaced immediately by your Wacker Neuson representative.

Protecting from moisture

Protect the machine against rain, snow or any other forms of moisture. This could cause damage or other malfunctions.

Protecting against extreme high or low temperatures

Do not expose the machine to extreme high or low temperatures. Otherwise the insulation current conducting parts can be damaged. Information on the permissible temperature range can be found in the chapter Technical data.

3.8 Safety during the operation of modular internal vibrator

Carrying belt (Accessories)

Wacker Neuson recommends the use of a carrying belt.

For further information, refer to chapter *Accessories*.

3.9 Maintenance

Maintenance work

Service and maintenance work must only be carried out to the extent described in these operating instructions. All additional work, e.g., the replacement of the power cable, must be carried out by the Wacker Neuson representative to prevent any safety risks.

For further information, refer to chapter *Maintenance*.

Disconnecting the machine from the electric power supply

Before carrying out service or maintenance work, pull the plug out of the plug receptacle in order to disconnect the machine from the electric power supply.

Cleaning

Always keep the machine clean and be sure to clean it each time you have finished using it.

Do not use gasoline or solvents. Danger of explosion!

Do not use high pressure washers. Permeating water can damage the machine. When electrical equipment is present, this can pose a serious injury risk from electric shocks.

4 Safety and information labels



Your machine has adhesive labels containing the most important instructions and safety information.

- Make sure that all the labels are kept legible.
- Replace any missing or illegible labels.

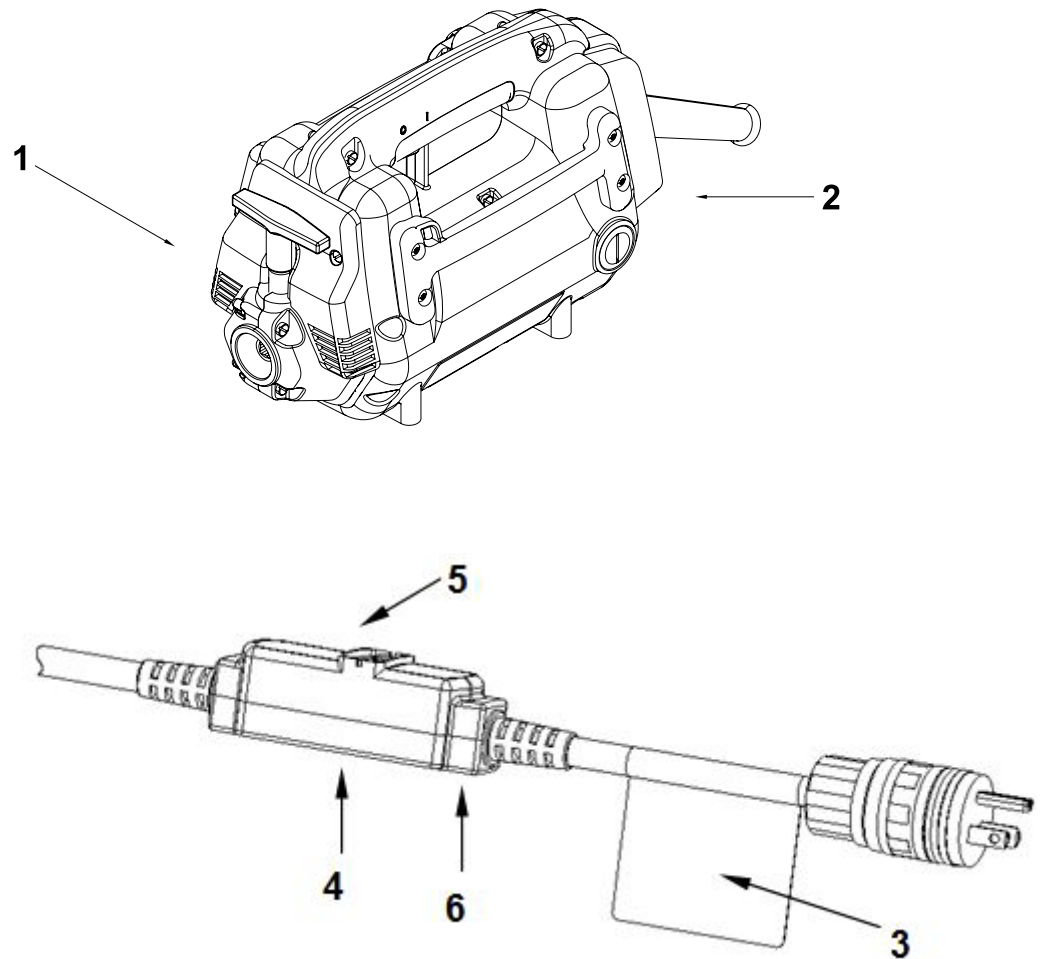
The item numbers for the labels are in the parts book.



4 Safety and information labels

| Item | Label | Description |
|------|--|--|
| 1 |  | <p>Warning Read operator’s manual to reduce risk of injury. Wear ear protection. Keep in operative position.</p> |
| 2 |  | <p>Warning of hot surface.</p> |
| 3 |  | <p>Warning Follow these important warnings to ensure proper operation and to reduce shock or fire hazard. Do not submerge in water. Please refer to UL LABEL on device for SPECIFIC WATTAGE. Avoid exposure to chemicals. Do not abuse. This device does not guard against electric shocks resulting from (a) possible defects or faults in an extension cord or other wiring supplying the GFCI, or (b) short circuits between hot and neutral conductors. If necessary, use only with #14AWG or larger (smaller numerical value) extension cord for 15A rated device and #12AWG or larger for 20A-rated device.</p> |

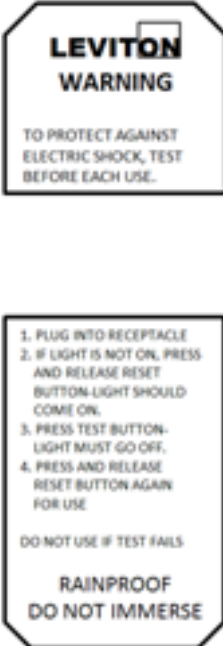
| Item | Label | Description |
|------|---|--|
| 4 |  | <p>Warning</p> <ol style="list-style-type: none"> 1. To ensure protection against electric shock, test the device before each use. When test button is pushed in the indicator light should go off. Reactivate the device by pushing the reset button and release. If the indicator light goes on, the device is ready for use. Do not use the device if the indicator light remains on, when the test button is pushed in. 2. This device does not guard against electric shocks resulting from (A) possible defect or faults in an extension cord or wiring supplying the GFCI, or (B) short circuits between hot and neutral conductors. If necessary, use only with #14AWG or larger (smaller numerical value) extension cord for 15A rated device and #12AWG or larger for 20A rated device. |
| 5 |  | <p>Warning</p> <p>To protect against electric shock, test before each use.</p> <ol style="list-style-type: none"> 1. Plug into receptacle. 2. If light is not on, press, and release reset button - light should come on. 3. Press test button - light must go off. 4. Press and release reset button again for use. <p>Do not use if test fails. Rainproof. Do not immerse.</p> |

4 Safety and information labels

| Item | Label | Description |
|------|---|--|
| 6 |  | UL label. GROUND FAULT CIRCUIT INTERRUPTER 2 POLE UNIT GFA15 AUTO RESET CLASS A RATING. 120VAC 60HZ 15A 1800W LEVITON MFG, CO. INC |

5 Scope of delivery

The scope of delivery includes:

- Drive motor.
- Operator's manual.
- Parts book.
- General safety instructions.

The HMS consists of several components (see the Technical Data chapter):

- Drive motor.
- Flexible shaft (optional).
- Vibrator head (optional).

Note: The components that are marked as "optional" must be ordered separately. Information about the configuration of an HMS can be found in the Allowable Combinations chapter.

6 Structure and function

6.1 Application

Use the machine only as intended, see chapter Safety, Proper use.

6.2 Field of application

The drive motor may only be used for the operation of flexible shafts and vibrator heads.

The combined HMS may be used for the following tasks:

- Compaction of fresh concrete.

6.3 Functionality

Principle

By means of the flexible shaft, the drive motor drives the vibrator head, which generates high-frequency vibrations. These vibrations will cause the vibrator head to execute precessions.

Concrete is deaerated and compressed in the effective range of the vibrator head when the vibrator head is immersed into the fresh concrete.

The fresh concrete is simultaneously cooling the vibrator head.

Note: The concrete is being compressed for as long as bubbles of air arise.

GFCI - Fault current protective switch

The GFCI monitors the incoming and outgoing operating currents and protects the user from electric shocks.

The control lamps of the GFCI light up green if the machine is correctly connected and there are no leakage currents. The control lamp goes out if there is a leakage current within the machine or if the electric power supply fails. In both cases, phase conductors and neutral conductors are interrupted by the GFCI.

The machine does not work. The electric power supply remains interrupted until the fault has been corrected and the electric power supply is restored or the reset push button has been pressed.

7 Components and operator's controls

7.1 Drive components and operator's controls

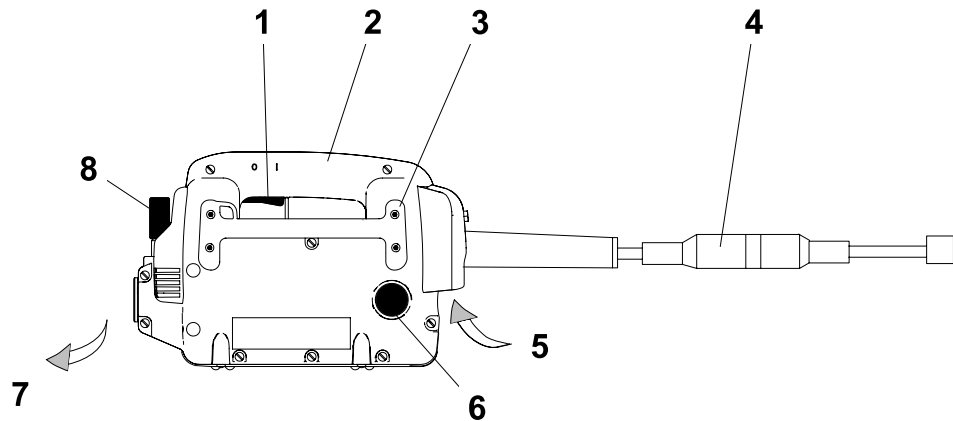

| Item | Designation | Item | Designation |
|------|--|------|----------------|
| 1 | ON/OFF switch | 5 | Air intake |
| 2 | Handle | 6 | Carbon brushes |
| 3 | Side handle | 7 | Air outlet |
| 4 | GFCI (Fault current protective switch) | 8 | T-handle |

Side handle

Each of the two side handles has an eye, to which a carrying belt (accessory) can be attached.

T-handle

The T-handle has different colors for different machine types, see the Technical Data chapter.

The quick disconnect coupler is opened with the T-handle, enabling a quick replacement and secure connection of the flexible shaft to the drive motor.

Air inlet and outlet

An air stream enters the drive motor housing through the air cleaner cartridge, cools the electric motor and leaves through the ventilation slots. The air stream is shown by arrows in the drawing.

Carbon brushes

The carbon brushes wear out during operation. If the carbon brushes are below the minimum length, the motor shuts off automatically.

7.2 Components of the HMS

Depending on the working conditions, you may be able to combine these components in a variety of configurations.

Information about the configuration of an HMS can be found in the Allowable Combinations chapter.

The HMS comprises the following components:

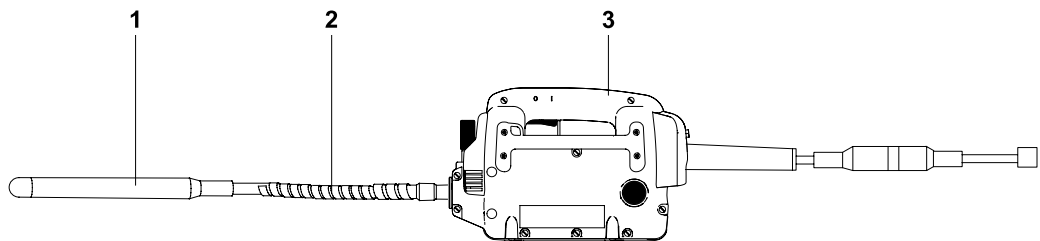

| Item | Designation | Item | Designation |
|------|---------------------------|------|--------------|
| 1 | Vibrator head (optional) | 3 | Drive motorr |
| 2 | Flexible shaft (optional) | | |

7.3 Flexible shaft components (optional)

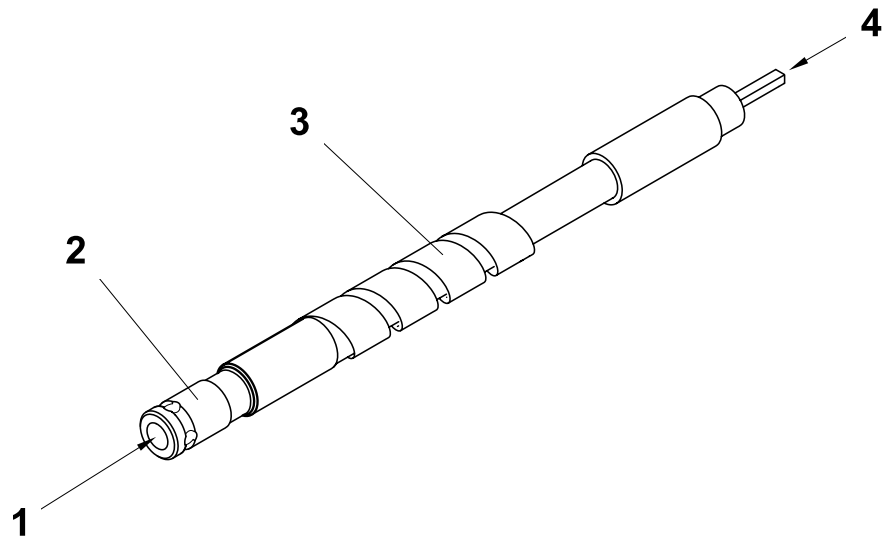

| Item | Designation | Item | Designation |
|------|---------------------------|------|-----------------------------|
| 1 | Connection to drive motor | 3 | Bend protection |
| 2 | Coupling | 4 | Connection to vibrator head |

7.4 Vibrator head components (optional)

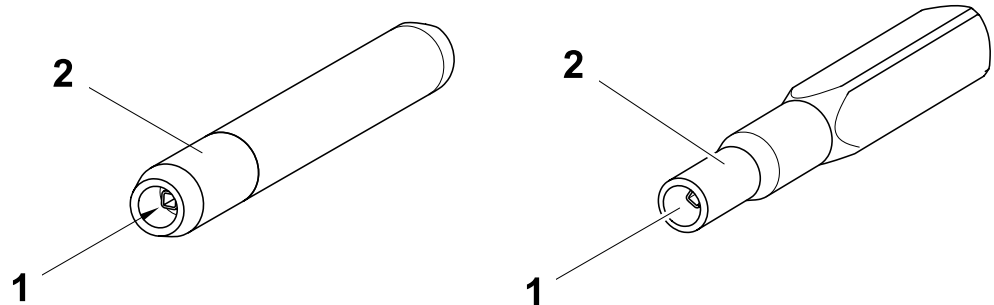

| Item | Designation | Item | Designation |
|------|------------------|------|--------------------|
| 1 | Connecting piece | 2 | Shaft core adapter |

8 Transport



WARNING

Improper handling can result in injury or serious material damage.

- ▶ Read and follow all safety information of this operator's manual, see chapter *Safety*.
-



WARNING

Hot vibrator head.

Touching it can cause burns.

- ▶ Only touch the vibrator head once the engine has cooled down.
 - ▶ Wear protective gloves.
-

Performing preparations

1. Switch off the drive motor via the ON/OFF switch.
2. Wait until the HMS has come to a complete standstill.
3. Pull the plug from the plug receptacle.
4. Disconnect the flexible shaft (incl. vibrator head) from the drive motor.
5. Allow drive motor and vibrator head to cool down.

Transporting the machine

1. Set the drive motor on or into a suitable transport vehicle (Operating position).
2. Wind up the power cable.
Note: Do not kink the power cable!
3. Place the flexible shaft (incl. vibrator head) in or on a suitable transport device.
4. Secure all components against falling or sliding.

9 Mounting the HMS

9.1 Pre-assembly the vibrator head



WARNING

Rotating parts.

Risk of injury to hands.

- ▶ Shut off drive.
- ▶ Disconnect the flexible shaft from the drive.

Working in the workshop

Perform maintenance work in a workshop on a workbench. This has the following benefits:

- Protection of the machine of contamination on the construction site.
- A level and clean work surface makes work easier.
- There is a better overview over small parts and they are not lost as easily.

Screwing the vibrator head on the flexible shaft

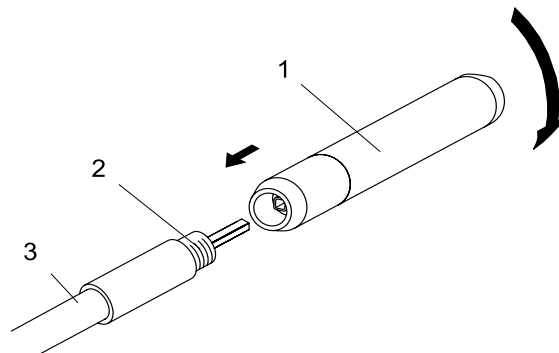

| Item | Designation | Item | Designation |
|------|---------------|------|----------------|
| 1 | Vibrator head | 3 | Flexible shaft |
| 2 | Thread | | |

1. Clamp flexible shaft in a vice with prism jaws.
2. Place pipe thread seal on the thread of the flexible shaft.
3. Place the vibrator head with the thread on the flexible shaft, while guiding the shaft core into the shaft core adapter of the vibrator head.
4. Screw the vibrator head on the flexible shaft (Caution! Left-hand thread) and tighten with large pipe wrench.
5. Let pipe thread seal cure for 24 hours.

Coupling the flexible shaft to the drive

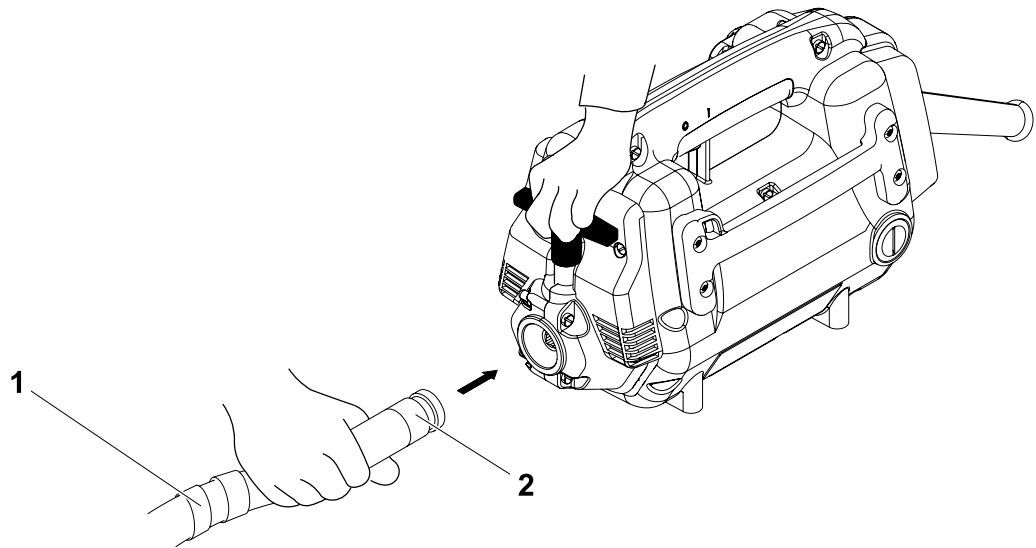

| Item | Designation |
|------|----------------|
| 1 | Flexible shaft |
| 2 | Coupling |

1. Switch off the drive motor via the ON/OFF switch.
2. Pull the plug from the plug receptacle.
3. Set drive motor on the floor..
4. Pull the T-handle upwards.
5. Insert the coupling of the flexible shaft into the quick disconnect coupler of the drive motor and make sure it engages, so that the shaft core fully enters the shaft core adapter on the drive motor.
6. Release the T-handle.
7. Turn the flexible shaft until the quick disconnect coupler engages.
8. Control whether the quick disconnect coupler is completely engaged by pulling on the flexible shaft.

Note: If the flexible shaft core is new, the drive motor must run approx. 5 minutes with the flexible shaft connected (if necessary with the vibrator head as well).

10 Use and operation



WARNING

Improper handling can result in injury or serious material damage.

- ▶ Read and follow all safety information of this operator's manual, see chapter *Safety*.



WARNING

Leakage current due to permeating moisture.

Injuries from electrocution.

- ▶ In moist environment keep or set the machine in operative position.
- ▶ Use extension cable of IPx4 design, so that the plug/coupling connection is protected from spraying water.

10.1 Prior to starting the machine

Requirements for operation

The HMS must only be operated under the following conditions:

- The HMS is pre-assembled according to this operator's manual.
 - The vibrator head is screwed on to the flexible shaft.
 - The flexible shaft (incl. vibrator head) is connected to the drive motor.

Note: For longer flexible shafts, Wacker Neuson recommends the use of a carrying belt (accessory).

Checking the machine

- ▶ Check the HMS and all components for damages.
- ▶ Check that the flexible shaft is firmly seated in the drive motor.
- ▶ Check the carrying belt (accessory) for damage.

Checking the mains

- ▶ Check if mains or power distribution on the construction site have the correct operating voltage (see nameplate of the machine or chapter *Technical Data*).
- ▶ Check if mains or power distribution on the constructions site are protected in accordance with current standards and regulations.

10.2 Starting up

Connecting the HMS to the power supply

NOTICE

Electrical voltage.

Incorrect voltage can cause damage on the machine.

- ▶ Check if the voltage of the current source corresponds with the information of the machine, see chapter Technical Data.
-



WARNING

Electrical voltage.

Injuries from electrocution.

- ▶ Check power cable and extension cable for signs of damage.
 - ▶ Only use extension cables for which grounded conductors are connected to the plug and the coupling (only for machines of class rating I, see chapter *Technical Data*).
-



WARNING

Starting of the machine.

Danger of injuries from uncontrolled starting of the machine.

- ▶ Deactivate the machine before connection to the electric power supply.
-



WARNING

Danger of electric shock and short-circuit!

Serious injuries from electric shock.

- ▶ Check power cable and extension cable for signs of damage.
 - ▶ Extension cable is not protected by GFCI.
 - ▶ Machines with damaged GFCI may not be operated.
 - ▶ The GFCI may only be replaced by a qualified electrician from Wacker Neuson service.
 - ▶ Never use the tool without the GFCI provided with the tool.
 - ▶ Always test the correct operation of the GFCI before starting work, unless the GFCI is of a selfchecking type.
 - ▶ Protect the GFCI from moisture. Do not submerge into water.
 - ▶ Avoid exposure of GFCI to chemicals.
 - ▶ Use only with extension cord described in chapter Technical Data.
-

**WARNING**

Danger of electric shock!

Serious injuries from electric shock.

The GFCI does not protect against:

- ▶ Electric shocks resulting from short circuits between hot and neutral conductors.
- ▶ Electric shocks resulting from possible defects or faults in an extension cord or other wiring supplying the GFCI.

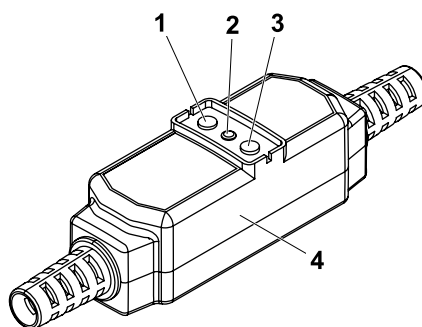
Overview - GFCI

| Item | Designation | Description |
|------|-------------------|--|
| 1 | Test push button | Checks whether the GFCI switching electronics are working. |
| 2 | Control lamp | Lights up if everything is in order. |
| 3 | Reset push button | Status - switched without errors. |
| 4 | Housing | Protects the switching electronics. |

Checking the GFCI for proper functioning

1. Turn off ON/OFF switch.

Note: When the ON/OFF switch is pressed, the HMS starts to run immediately at the connection. The Vibrator head can strike out and may injure persons or be damaged.

2. If required, connect a permitted extension cable to the power cable of the machine.

Note: See chapter Technical data for the permitted lengths and cross-section areas of extension cables.

3. Insert the plug into the plug receptacle.
4. Press push button 'Test' on GFCI. Inside the GFCI a leakage current will be simulated to test the switching device, the GFCI switches off and the indicator light goes off.
5. Press push button 'Reset' on GFCI or pull the plug out of the plug receptacle and then plug back the plug into the plug receptacle.

The control lamps of the GFCI light up if the machine is correctly connected and there are no leakage currents.

The control lamp of the GFCI does not light up if there is a malfunction or fault, see chapter *Malfunctions*.

Switching on the machine

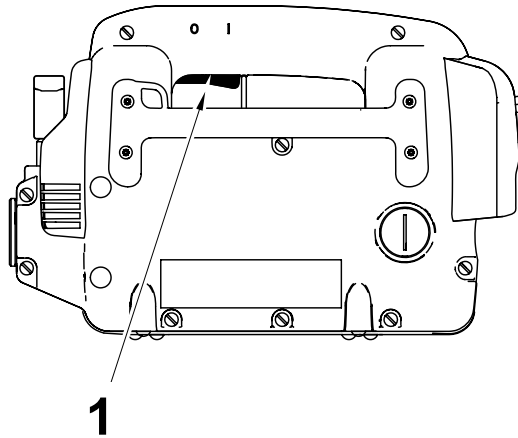

| Item | Designation |
|------|---------------|
| 1 | ON/OFF switch |

1. Hold the machine in one hand.
2. With the other hand, pick up the protective hose so that the vibrator head does not thrash about.
3. Switch on the machine via the ON/OFF switch.

Note: For flexible shafts over 2 m, ask a helper to pick up the vibrator head off the floor by the protective hose in order to prevent damage to the machine or the ground.

Compacting fresh concrete

1. Quickly immerse the vibrator head in the fresh concrete, hold it for several seconds and slowly pull it out again.
2. Immerse the vibrator head in all areas of the formwork and compact the fresh concrete.

Note:

- Compact especially intensively in the area of formwork corners. In these areas, the reinforcement rate is the highest.
- Avoid contact of the vibrator head with the concrete reinforcement. The following damages are possible if the vibrator head comes into contact with the concrete reinforcement:
 - The connection of the concrete to the reinforcement can be lost.
 - The machine can be damaged.
- The result of the compacting depends on the following points:
 - Holding time of the vibrator head in the concrete.
 - Diameter of the vibrator head.
 - Consistency of the concrete.
 - Reinforcement rate.

If you use a vibrator head with a smaller diameter, the compacting time to achieve the same results as with a vibrator head with a larger diameter will increase.

- Indications that the concrete is sufficiently compacted:
 - The concrete no longer sets.
 - Air bubbles no longer or rarely rise.
 - The sound of the vibrator head is not changing anymore.

10.3 Decommissioning

Switching off the machine



CAUTION

The vibrator head moves if it is turned on and not immersed in the fresh concrete.

Danger of injury or danger of damage to property by uncontrolled vibrator head.

- ▶ Switch the machine off before you put it down.



CAUTION

The vibrator head heats up if it is turned on and not immersed in the fresh concrete.

Hot surface can cause burns.

Damage to the machine with excessive wear.

- ▶ Do not operate the machine with the internal vibrator not immersed in the fresh concrete.

1. Slowly remove the vibrator head from the fresh concrete and hold it in the air.
2. Switch off the machine via the ON/OFF switch.
3. Wait until the machine has come to a complete standstill.
4. Slowly set down the machine (operative position), lay down the associated flexible shaft and vibrator head.

Note: Do not kink the protective hose and power cable.

5. Pull the plug from the plug receptacle.
6. Allow for the unit to cool.

Disconnecting the flexible shaft from the drive



CAUTION

Risk of burns from hot coupling on the flexible shaft.

- ▶ Always wear protective gloves when holding the coupling.

1. T-handle.
2. Remove the flexible shaft coupling from the drive coupling.
3. Release the T-handle.
4. Set down the machine securely on a firm and level surface so that the drive motor cannot tip over, fall or slide away.

Cleaning the machine

All components of the HMS must be cleaned after each use.

1. Clean the vibrator head and flexible shaft with water.

Note: You can remove concrete residue when the machine is running by immersing the vibrator head in gravel.

2. Wipe the drive motor and flexible shaft with a clean, damp cloth.
3. Clean the ventilation slots with a suitable non-metallic tool.

11 Maintenance



WARNING

Improper handling can result in injury or serious material damage.

- ▶ Read and follow all safety instructions of this operator's manual, see chapter *Safety*.
-



WARNING

Electrical voltage.
Injuries from electrocution.

- ▶ Remove the plug from the plug receptacle before all work on the machine.
-



WARNING

Improper handling may cause a danger to life by electrocution.

- ▶ Only a qualified electrician is permitted to open the machine, perform repairs, and perform a subsequent safety check in accordance with applicable regulations.
-



WARNING

Hot machine
Touching it can cause burns.

- ▶ Only touch the machine once the engine has cooled down.
-

11.1 Maintenance personnel qualifications

Qualifications for maintenance work

The maintenance tasks described in this operator's manual may be performed by any responsible user unless otherwise stated.

Some maintenance tasks may only be performed by specially trained personnel or by the service staff of your Wacker Neuson contact — these are specifically noted.

11.2 Maintenance schedule

Note: The time intervals mentioned here are reference values for normal operation. For extreme operation, e.g. continuous use, the service intervals should be halved.

11.2.1 Drive motor

| Task | Daily before operation | Every 50 hrs. |
|---|------------------------|---------------|
| Check power cable for perfect condition – if power cable is defective, have it replaced. * | ■ | |
| Visual inspection of all parts for damage. | ■ | |
| Checking the GFCI for proper functioning. | ■ | |
| Machine cleaner: <ul style="list-style-type: none"> ■ Air outlet ■ Air vents on the air outlet. | ■ | |
| Clean the filter element. | | ■ |
| Check carbon brushes – replace if necessary. | | ■ |

* Have these tasks carried out by the service department of your Wacker Neuson contact person.

11.2.2 HMS

| Task | Daily before operation | Every 50 hrs. | Every 100 hrs. | Every 300 hrs. |
|---|------------------------|---------------|----------------|----------------|
| Visual inspection of all parts for damage. | ■ | | | |
| Check that the connections are tight: <ul style="list-style-type: none"> ■ Flexible shaft – vibrator head: Tighten if necessary ■ Flexible shaft – drive: If necessary, securely engage the coupling. | ■ | | | |
| Clean HMS. | ■ | | | |

| Task | Daily before operation | Every 50 hrs. | Every 100 hrs. | Every 300 hrs. |
|---|------------------------|---------------|----------------|----------------|
| Check wear dimensions of the vibrator head. | | ■ | | |
| Lubricate flexible shaft and replace plastic bushing. | | | ■ | |
| Change oil in vibrator head. * | | | | ■ |

* Have these tasks carried out by the service department of your Wacker Neuson contact person.

11.3 Maintenance work

Working in the workshop

Perform maintenance work in a workshop on a workbench. This has the following benefits:

- Protection of the machine of contamination on the construction site.
- A level and clean work surface makes work easier.
- There is a better overview over small parts and they are not lost as easily.

Visual inspection for damage



WARNING

A damaged machine part, protective hose or power cable can result in personal injury caused by electric current.

- ▶ Do not operate a damaged machine.
- ▶ Have a damaged machine repaired immediately.

- ▶ All of the components of the HMS for damage check.
- ▶ Drive motor and GFCI check for any damage, cracks or.
- ▶ ON/OFF switch on the drive motor to check the function.
- ▶ See *the Use and Operation* chapter for how to check the GFCI for proper functioning.

11.3.1 Clean HMS

After use, clean HMS.

Note: Do not clean the machine with high pressure washers or steam jet cleaners!

- ▶ Wipe the drive motor and the Flexible shaft with a damp and clean cloth.
- ▶ Clean the ventilation slots with a suitable non-metallic tool.
- ▶ Clean the vibrator head and protective hose with water.

Note: You can remove concrete residuals by immersing the running machine into gravel.

11.3.2 Drive motor

Clean the filter element

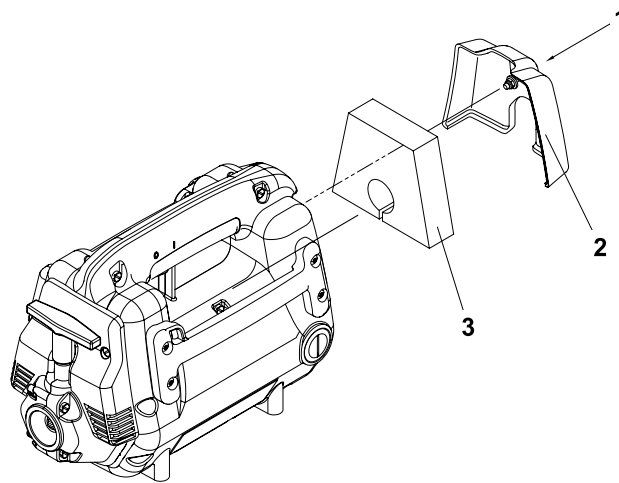

| Item | Designation | Item | Designation |
|------|-------------|------|----------------|
| 1 | Screw | 3 | Filter element |
| 2 | Cap | | |

1. On/Off-switch OFF.
2. Wait until the HMS has come to a complete standstill.
3. Pull the plug from the plug receptacle.
4. Loosen the screw and remove the cover.
5. Filter element remove and wash with cold water.
Note: Replace the filter element, if it is stained.
6. Insert dry filter element.
7. Replace cap.
8. Screw and tighten by hand.

Checking/replacing the carbon brushes



WARNING

Improper replacement of parts.
Danger of electrocution.

- ▶ Only a qualified electrician is permitted to replace parts and perform a subsequent safety check according to the directives in effect.

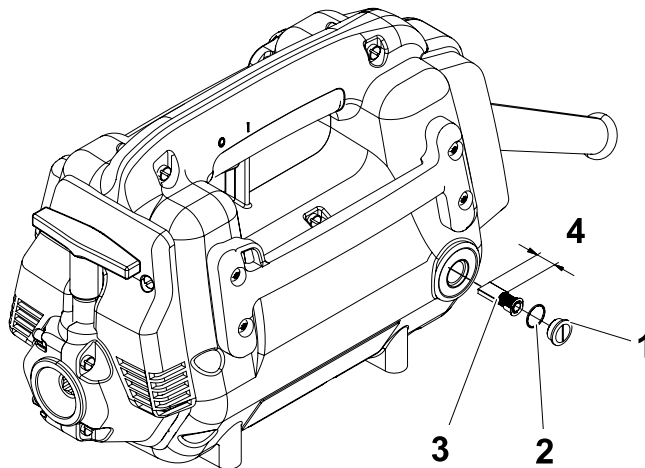

| Item | Designation | Item | Designation |
|------|-------------|------|------------------------------|
| 1 | Cap | 3 | Carbon brushes |
| 2 | O-ring | 4 | Minimum length 10mm (0.4 in) |

Performing preparations

1. On/Off-switch OFF.
2. Wait until the HMS has come to a complete standstill.
3. Pull the plug from the plug receptacle.
4. Remove any dirt around the cap.

Removing the carbon brushes

1. Unscrew the caps (on both sides of the drive motor) with a suitable flat-head screwdriver and remove with the O-ring.
2. Mark the position and location of the carbon brush with a pencil for reinstalling.
3. Remove carbon brush.

Checking the carbon brushes

- ▶ Check that both carbon brushes are at least the minimum length.

Note: If one carbon brush is smaller than the minimum length, both carbon brushes must be replaced.

Inserting the carbon brushes

1. Install carbon brush (on both sides of drive motor). Pay attention to the original position and location of used carbon brushes, to avoid damage and sparking on the collector.
2. Screw on cap with o-ring and tighten with a screwdriver hand tight.

Note: If you have installed new carbon brushes, the drive must be run for approx. 5minutes without the flexible shaft attached.

11.3.3 Flexible shaft

Removing the shaft core

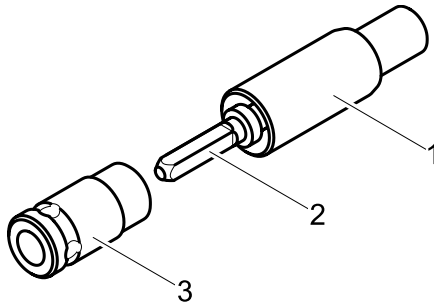

| Item | Designation | Item | Designation |
|------|----------------|------|-------------|
| 1 | Flexible shaft | 3 | Coupling |
| 2 | Shaft core | | |

1. Remove any dirt around the coupling.
2. Clamp flexible shaft in a vice with prism jaws.
3. Unscrew coupling with large pipe wrench or special wrench (accessory).
4. Remove the shaft core completely from the protective hose.
5. Wipe off the shaft core with a clean, lint-free cloth.

Note: Do not clean the shaft core or the protective hose with solvent!

6. Clean the thread of the coupling and the flexible shaft with a wire brush and cleaning agent.

Replacing the plastic bushing

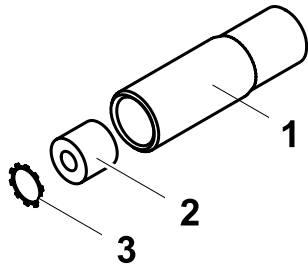

| Item | Designation | Item | Designation |
|------|-----------------|------|----------------|
| 1 | Flexible shaft | 3 | Retaining clip |
| 2 | Plastic bushing | | |

1. Remove retaining clip with a screwdriver.
2. Pull out plastic bushing with a pulling tool if necessary.
3. Wipe off bearing surface with a clean, lint-free cloth.
4. Push in a new plastic bushing.
5. Place the retaining clip on with the concave side to the inside, until all the teeth engage in the groove.

Lubricating the shaft core

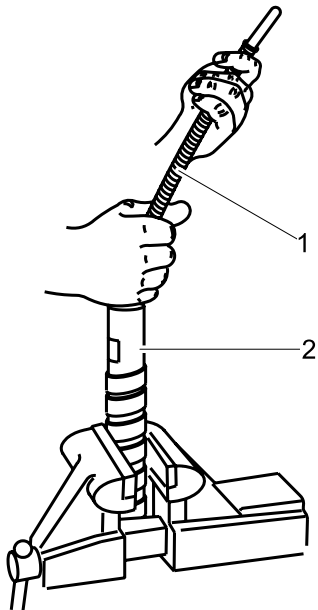

| Item | Designation |
|------|-----------------|
| 1 | Shaft core |
| 2 | Protective hose |

Note: If the flexible shaft is damaged or has grooves, the flexible shaft must be replaced.

- ▶ Lubricate the shaft core thinly and uniformly with special lubricant (accessories) using your hands.

Assembling the flexible shaft

1. Insert the shaft core completely in the protective hose while turning. Turning the shaft core lubricates the special lubricant.
2. Guide the shaft core in the shaft core adapter of the vibrator head.
3. Place pipe thread seal (accessory) on the thread of the coupling.
4. Screw the coupling onto the flexible shaft and tighten with large pipe wrench or special wrench (accessory).
5. Check the shaft core for free movement, while turning with the special wrench (accessory).

Note: If the shaft core is new, the drive must run approx. 5minutes with the flexible shaft connected (if necessary with the vibrator head as well).

11.3.4 Vibrator head

Checking wear dimensions of the vibrator head

Wear dimensions:

- Vibrator head minimum diameter (H vibrator head).
- Minimum width across flats (HA vibrator head).

Wear is highest at the end of the vibrator head.

Let the lower tube be exchanged by your Wacker Neuson contact if the wear dimensions are reached at a certain point.

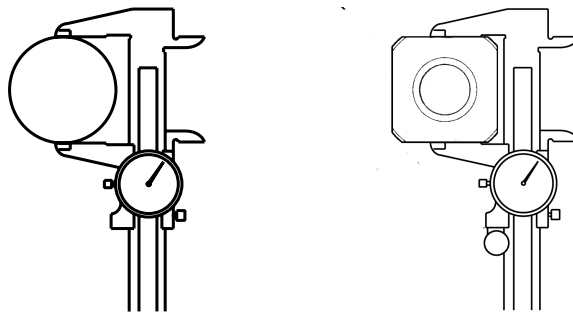

| Vibrator head | Wear dimension | | Original dimension | |
|---------------|----------------|------|--------------------|------|
| | [mm] | [in] | [mm] | [in] |
| H 25, H 25S | 24,0 | 0.94 | 25,0 | 0.98 |
| H 35, H 35S | 32,0 | 1.26 | 35,0 | 1.38 |
| H 45, H 45S | 41,0 | 1.61 | 45,0 | 1.77 |
| H 55 | 52,0 | 2.05 | 57,0 | 2.24 |
| H 65 | 58,0 | 2.28 | 65,0 | 2.26 |
| H 25HA | 25,0 | 0.98 | 26,2 | 1.03 |
| H 35HA | 32,0 | 1.26 | 36,0 | 1.42 |
| H 45HA | 39,0 | 1.54 | 45,0 | 1.77 |
| H 50HA | 46,0 | 1.81 | 50,0 | 1.97 |

Changing the oil in the vibrator head

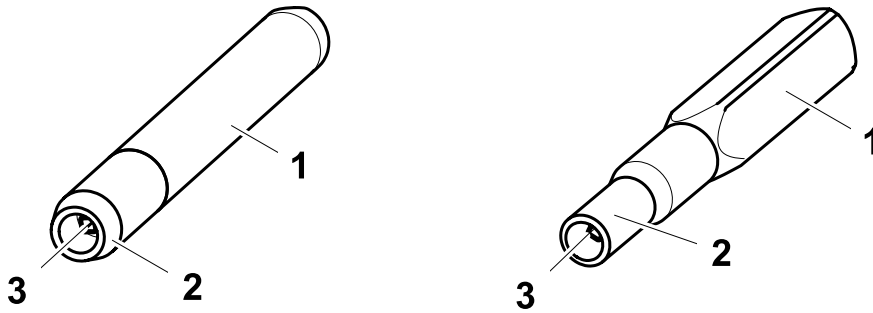

| Item | Designation | Item | Designation |
|------|------------------|------|--------------------|
| 1 | Housing | 3 | Shaft core adapter |
| 2 | Connecting piece | | |

Opening the vibrator head

1. Remove any dirt around the connecting piece.
2. Clamp flexible shaft in a vice with prism jaws.
3. Unscrew the vibrator head from the flexible shaft with a large pipe wrench (Caution! Left-hand thread).
4. Clean the thread of the vibrator head and the flexible shaft with a wire brush and cleaning agent.
5. Clamp the vibrator head in the area of the connecting piece.
6. Unscrew the housing from the connecting piece with a large pipe wrench.

Changing the oil

1. Pour out oil and dispose of environmentally friendly.
2. Clean the threads of the connecting piece and the vibrator head with a wire brush and cleaning agent.
3. Fill oil in the housing according to specification and in the correct amount, see chapter Technical Data.

Assembling the vibrator head

1. Place pipe thread seal on the thread of the housing.
2. Screw the housing on the connecting piece and tighten with a large pipe wrench.
3. Place pipe thread seal on the thread of the flexible shaft.
4. Place the vibrator head with the thread on the flexible shaft, while guiding the shaft core into the shaft core adapter of the vibrator head.
5. Screw the vibrator head on the flexible shaft (Caution! Left-hand thread) and tighten with large pipe wrench.
6. Let pipe thread seal cure for 24hours.

12 Malfunctions

Please refer to the following table if the machine does not work properly. It contains potential faults, their causes and remedies.

| Malfunction | Cause | Remedy |
|---|--|--|
| HMS not in operation. | Power supply is interrupted. | Check power cable and GFCI, have it re-placed if defective. * |
| | Carbon brushes worn. | Replace carbon brushes. |
| | ON/OFF switch defective. | Have ON/OFF switch replaced. * |
| | Electric power supply fuse triggered. | Activate fuse. |
| | Drive motor burned through. | Replace drive motor. |
| HMS cuts out. | Carbon brushes worn. | Replace carbon brushes. |
| Drive motor runs very loud. | Carbon brushes broken. | Replace carbon brushes. |
| | Drive motor bearing worn. | Have machine parts replaced. * |
| | Rotor schleift am Stator. | |
| Drive motor runs normally, but over-heated. | Air cleaner, ventilation grill or ventilation slots are plugged. | Remove dirt, replace air cleaner if necessary. |
| | Too much special lubricant in the flexible shaft. | Remove excess special lubricant with a cloth replace or flex shaft. |
| | Too much oil in the vibrator head. | Remove excess oil. |
| Drive motor runs slow and over-heats. | Input voltage too low. | Provide correct line voltage. |
| | Wire cross-section of extension cable is too small. | Use extension cable with sufficient wire cross-section. |
| | Incorrect combination of vibration head and flexible shaft. | Only use combination according to the table, see chapter Technical Data. |
| | Shaft core of the flexible shaft not sufficiently lubricated. | Lubricate shaft core. |
| | Vibrator head bearing or drive bearing worn. | Have machine parts replaced. * |
| | Rotor grinds on stator. | |

| Malfunction | Cause | Remedy |
|---|--|---|
| Control lamp does not light up. The line voltage is applied. | <ul style="list-style-type: none"> ■ GFCI has turned off the machine. ■ Machine malfunction. | <ol style="list-style-type: none"> 1. Pull the plug from the plug receptacle. 2. Check power cable for damage – if damaged, have it replaced. * 3. Insert the plug into the plug receptacle. <p>If the fault is not remedied, have the machine repaired. *</p> |
| | <ul style="list-style-type: none"> ■ Water in the drive motor. ■ Defect in the drive motor. | Have the machine repaired. * |
| Control lamp does not light up. | No line voltage. | <ol style="list-style-type: none"> 1. Pull the plug from the plug receptacle. 2. Check power cable for damage – if damaged, have it replaced. * 3. Insert the plug into the plug receptacle. |
| | GFCI is defective. | Have the machine repaired. * |
| | Plug is defective. | Have the machine repaired. * |
| | Control lamp is defective. | Have the machine repaired. * |

* Have these tasks carried out by the service department of your Wacker Neuson representative person.

13 Allowable combination

You can combine these components in various designs depending upon the conditions of use.

13.1 Drive motor – Flexible shafts – Vibrator head

NOTICE

A vibrator head which is too large or flexible shaft which is too long overloads the drive.

Excessive wear and damage of the components is possible.

- ▶ Only use allowable combinations of components.

Explanation:

- + This combination is allowed.
- (+) This combination is allowed, but not recommended.
- This combination is not allowed.

| Vibrator head | Drive motor | Flexible shafts | | |
|---------------|-------------|-----------------|-------|-------|
| | | SM1-E | SM2-E | SM4-E |
| H 25 H 25S | M 1000 | + | + | + |
| | M 2000 | (+) | (+) | (+) |
| | M 3000 | (+) | (+) | (+) |
| H 25HA | M 1000 | + | + | + |
| | M 2000 | + | + | + |
| | M 3000 | + | + | + |

| Vibrator head | Drive motor | Flexible shafts | | | | | | | |
|---|-------------|-----------------|-------|-------|-------|-------|-------|-------|-------|
| | | SM0-S | SM1-S | SM2-S | SM3-S | SM4-S | SM5-S | SM7-S | SM9-S |
| H 35 H 35S | M 1000 | + | + | + | + | + | + | — | — |
| | M 2000 | + | + | + | + | + | + | + | + |
| | M 3000 | + | + | + | + | + | + | + | + |
| H 35HA H 45 H 45S H 45HA H 50HA H 55 H 65 | M 1000 | — | — | — | — | — | — | — | — |
| | M 2000 | + | + | + | + | + | + | + | + |
| | M 3000 | + | + | + | + | + | + | + | + |

14 Disposal

14.1 Disposal of waste electrical and electronic equipment

For customers in EU countries

This device is subject to the European Directive 2002/96/EC on waste electrical and electronic equipment (WEEE) and the corresponding national legislation. The WEEE directive outlines the procedure for handling electrical waste equipment across the EU.



The device is labelled with the symbol of a crossed out dustbin shown here. This means you may not dispose of it with normal household waste but in a separate environmentally-friendly waste collection.

This device is a professional electrical tool designed for commercial applications only (B2B device according to WEEE directive). Contrary to equipment used in most private households (B2C devices), in some EU countries such as Germany, this device may not be disposed of at a collection point in a public disposal facility (for example at public waste depots). In case of doubt, ask the sales outlet about the proper disposal procedure for B2B electrical equipment in your country and ensure you dispose of the device in accordance with the valid legal guidelines. Please also note any information in the sales contract and the general terms and conditions from the point of sales.

The proper disposal of this device prevents the occurrence of any negative effects on people or the environment, follows the specific procedures for handling harmful substances and enables valuable raw materials to be recycled.

For customers in non-EU countries

The proper disposal of this device prevents the occurrence of any negative effects on people or the environment, follows the specific procedures for handling harmful substances and enables valuable raw materials to be recycled. Therefore, we recommend that this device is disposed of in a separate, environmentally-friendly waste collection and not with normal household waste. In some cases, national legislation also stipulates the separate disposal of electric and electronic products. Please ensure you dispose of this device in accordance with the valid regulations in your country.

15 Accessories

There is a wide range of accessories available for the machine.

For more information on the individual accessories, visit the following website:
www.wackerneuson.com.

15.1 Special wrench for flexible shaft

The flexible shaft coupling can be removed easier with the special wrench.

15.2 Pipe thread seal

The pipe thread seal is needed for sealing the thread connection between the vibrator head and the flexible shaft, as well as between coupling and flexible shaft.

15.3 Special lubricant for flexible shafts

The Wacker Neuson special lubricant is needed for lubricating flexible shaft cores in the flexible shafts.

15.4 SS-adapter

The SS-adapter is used to connect two S-flexible shafts.

NOTICE

Engine overload.

Flexible shafts which are too long can overload the engine.

- Keep a total length of 9 m.
-

Various lengths of flexible shafts is found in the *Technical Data* chapter.

15.5 Carrying belt for the drive motor



WARNING

Improper use of accessories can result in injury or serious material damage.

- ▶ Only fasten the carrying belt to the rear handle of the drive.
-

For longer flexible shafts, use a carrying belt to make the work easier.

You can carry the drive motor with the carrying belt, if you must often change position.

16 Technical data

16.1 Drive motor

| Designation | Unit | M1000/120/GFCI | M2000/120/GFCI | M3000/120/GFCI |
|---|---------------------------------------|--------------------|--------------------|----------------|
| Item no. | | 5100002955 | 5100002956 | 5100002957 |
| T-Handle (Color) | | Green | Yellow | Red |
| Rated current | A | 10,0 | 15,0 | |
| Rated voltage | V | 120 | | |
| Rated frequency | Hz | 50 – 60 | | |
| Phases | ~ | 1 | | |
| Length | mm (in) | 500 (19.7) | | |
| Width | mm (in) | 170 (6.7) | | |
| Height | mm (in) | 210 (8.3) | | |
| Length of cable | m (ft) | 0,5 (1.6) | | |
| Weight | kg (lb) | 5,5 (12.1) | 6,2 (13.7) | 8,3 (18.3) |
| Plug | | NEMA 5-15P 14W47 | | |
| Engine type | | Universal motor | | |
| Rated input power | kW | 1,20 | 1,80 | |
| Rated speed | min ⁻¹ (rpm) | 11.500 (11,500) | 12.000 (12,000) | |
| Class rating | | II | | |
| Protection class | | IP 24 | | |
| Sound pressure level L _{pA} | dB(A) | 85,0 | | |
| Standard | | DIN EN ISO 11201 | | |
| Vibration total value a _{hv} | m/s ² ft/s ² | 5,0 (16.4) | | |
| Standard | | DIN EN ISO 28927 | | |
| Uncertainty of measurement of vibration total value a _{hv} | m/s ² ft/s ² | 1,0 (3.3) | | |

16.2 E-Flexible shafts (optional)

| Designation | Unit | SM1-E | SM2-E | SM4-E |
|-------------|---------|-----------|-----------|------------|
| Length | m (ft) | 1.0 (3.3) | 2.0 (6.6) | 4.0 (13.1) |
| Weight | kg (lb) | 1.5 (3.2) | 2.5 (5.5) | 4.3 (9.4) |

16.3 S-Flexible shafts (optional)

| Designation | Unit | SM0-S | SM1-S | SM2-S | SM3-S |
|-------------|---------|-----------|-----------|-----------|------------|
| Length | m (ft) | 0.5 (1.6) | 1.0 (3.3) | 2.0 (6.6) | 3.0 (9.8) |
| Weight | kg (lb) | 1.3 (2.9) | 2.7 (6.0) | 4.3 (9.5) | 5.9 (13.0) |

| Designation | Unit | SM4-S | SM5-S | SM7-S | SM9-S |
|-------------|---------|------------|------------|-------------|-------------|
| Length | m (ft) | 4.0 (13.1) | 5.0 (16.4) | 7.0 (23.0) | 9.0 (29.5) |
| Weight | kg (lb) | 7.1 (15.7) | 9.3 (20.5) | 12.9 (28.4) | 15.1 (33.3) |

16.4 Standard vibrator head (optional)

| Designation | Unit | H25 | H25 S | H35 | H35 S |
|--------------------------|---------|---------------|-------------|------------|------------|
| Vibration range in air | mm (in) | 1,1 (0.043) | 0,8 (0.031) | 2,2 (0.1) | 1,7 (0.1) |
| Vibrations | 1/min | 12,000 | | | |
| Vibrations | Hz | 200 | | | |
| Bottle shape | | Round | | | |
| Bottle diameter/diagonal | mm (in) | 25 (1.0) | | 35 (1.4) | |
| Length of vibrator head | mm (in) | 440 (17.3) | 295 (11.6) | 410 (16.1) | 310 (12.2) |
| Weight | kg (lb) | 1,3 (2.9) | 0,8 (1.8) | 2,1 (4.7) | 1,7 (3.6) |
| Oil specification | | Synthetic oil | | | |
| Oil quantity | l | 0,010 | | 0,015 | |

| Designation | Unit | H45 | H45 S | H55 | H65 |
|--------------------------|---------|---------------|------------|------------|------------|
| Vibration range in air | mm (in) | 2,7 (0.1) | 1,8 (0.1) | 3,1 (0.1) | 3,2 (0.1) |
| Vibrations | 1/min | 12.000 | | | |
| Vibrations | Hz | 200 | | | |
| Bottle shape | | Round | | | |
| Bottle diameter/diagonal | mm (in) | 45 (1.8) | | 57 (2.2) | 65 (2.6) |
| Length of vibrator head | mm (in) | 385 (15.2) | 305 (12.0) | 410 (16.1) | 385 (15.2) |
| Weight | kg (lb) | 3,4 (7.5) | 2,8 (6.2) | 5,3 (11.7) | 6,2 (13.7) |
| Oil specification | | Synthetic oil | | | |
| Oil quantity | l | 0,022 | 0,019 | 0,033 | 0,044 |

16.5 HA-Vibrator head (optional)

| Designation | Unit | H25HA | H35HA | H45HA | H50HA |
|--------------------------|-------------|---------------|--------------|--------------|--------------|
| Vibration range in air | mm (in) | 2,1 (0.1) | 2,1 (0.1) | 3,0 (0.1) | 3,5 (0.1) |
| Vibrations | 1/min | 12.000 | | | |
| Vibrations | Hz | 200 | | | |
| Bottle shape | | Square | | | |
| Bottle diameter/diagonal | mm (in) | 26 (1.0) | 36 (1.4) | 45 (1.8) | 50 (2.0) |
| Length of vibrator head | mm (in) | 380 (15.0) | 405 (15.9) | 390 (15.4) | 395 (15.6) |
| Weight | kg (lb) | 1,3 (2.8) | 2,3 (5.1) | 3,3 (7.3) | 3,9 (8.6) |
| Oil specification | | Synthetic oil | | | |
| Oil quantity | l | 0,010 | 0,020 | 0,030 | 0,050 |

16.6 Extension cable



WARNING

Electrical voltage.
Injuries from electrocution.

- ▶ Check power cable and extension cable for signs of damage.
- ▶ Only use extension cables for which grounded conductors are connected to the plug and the coupling (only for machines of class rating I, see chapter *Technical Data*).

- Only use permitted extension cables, see chapter *Safety*.
- Refer to the following table for the required cross-section area of the extension cable:

Note: Refer to the nameplate or the chapter *Technical data* (via the item number) for the type designation and voltage rating of your machine.

| Machine | Voltage [V] | Extension [m] | Cross-section area of cable [mm ²] |
|----------------|-------------|---------------|--|
| M1000 | 120 1~ | ≤ 31 | 1,5 |
| | | ≤ 52 | 2,5 |
| | | ≤ 82 | 4,0 |
| M2000 M3000 | 120 1~ | ≤ 21 | 1,5 |
| | | ≤ 35 | 2,5 |
| | | ≤ 55 | 4,0 |

Example

You utilize an M1000/120 and want to use an extension cable with a length of 25 m.

The machine has an input voltage of 120 V.

According to the table, the extension cable must feature a cross-section area of 2.5 mm².

US Machine

| Machine | Voltage V | Extension ft | Cross-section area of cable AWG |
|----------------|--------------|-----------------|---------------------------------------|
| M1000 | 120 1~ | ≤ 90 | 16 |
| | | ≤ 142 | 14 |
| | | ≤ 224 | 12 |
| M2000 M3000 | 120 1~ | ≤ 60 | 16 |
| | | ≤ 95 | 14 |
| | | ≤ 149 | 12 |
| | | ≤ 235 | 10 |

17 Glossary

Class rating

The class rating according to DIN EN 61140 specifies the safety measures for electrical equipment to avoid electrocution. There are four class ratings:

| Class rating | Meaning |
|--------------|--|
| 0 | No special protection apart from the basic insulation. No grounded conductor. Plug connection without grounded conductor contact. |
| I | Connection of all conductive housing components to the grounded conductor. Plug connection with grounded conductor contact. |
| II | Reinforced or double insulation (protective insulation). No connection to the grounded conductor. Plug connection without grounded conductor contact. |
| III | Machines are operated on protective low voltage (< 50 V). Connection to the grounded conductor is not necessary. Plug connection without grounded conductor contact. |

Protection class IP

The protection class according to DIN EN 60529 indicates the suitability of electrical equipment for use in certain ambient conditions as well as the protection against risks.

The protection class is specified by an IP code according to DIN EN 60529.

| Code | Meaning 1st number: Protection against touching hazardous parts. Protection against permeating foreign objects. |
|------|---|
| 0 | Not protected against contact. Not protected against foreign bodies. |
| 1 | Protected against contact with the back of the hand. Protected against large foreign objects with diameter > 50 mm (1.9 in). |
| 2 | Protected against contact with one finger. Protected against medium-sized foreign objects (diameter > 12.5 mm (0.5 in)). |
| 3 | Protected against touch with a tool (diameter > 2.5 mm (0.01 in)). Protected against small foreign objects with (diameter > 2.5 mm (0.01 in)). |
| 4 | Protected against touch with a wire (diameter > 1 mm (0.03 in)). Protected against granular foreign objects (diameter > 1 mm (0.03 in)). |
| 5 | Protected against contact. Protected against dust depositing inside. |
| 6 | Completely protected against any contact. Protected from dust. |

| Code | Meaning 2nd number: Protection against permeating water |
|------|--|
| 0 | Not protected against permeating water. |
| 1 | Protected against water dropping vertically. |
| 2 | Protected against diagonally falling water (15° angle). |
| 3 | Protected against spray (60° angle). |
| 4 | Protected against spraying water from all directions. |
| 5 | Protected against water jets (nozzle) from any angle. |
| 6 | Protected against strong water jets (overflow). |
| 7 | Protected from temporary immersion in water. |
| 8 | Protected from ongoing immersion in water. |

