

FJ Series General Purpose Hydraulic Cylinder

φ 30 to φ 250 × 1000ST
7, 14MPa

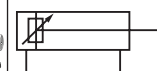

Features

- ① Standard series that conforms with JIS standards (JIS B8354-1985) A high level of general compatibility and interchangeability, plus very stable performance and quality.
- ② All component parts are completely standardized for quick delivery and easy parts replacement, maintenance, and inspection.
- ③ Specially selected materials used in tubes, rods, packing, bolts and all other parts ensures durability. In a tough environment.

For details see catalog number 9214.

Specifications

Item	7MPa{71.4kgf/cm ² }Series	14MPa{143kgf/cm ² }Series	Remarks
Maximum Working Pressure	7MPa{71.4kgf/cm ² }	14MPa{143kgf/cm ² }	When using a meter out inhibitor, take care that pressure generated in the rod side cylinder chamber does not exceed the limits shown to the left.
Withstand Pressure	10.5MPa{107kgf/cm ² }	21MPa{214kgf/cm ² }	
Minimum Operating Pressure	0.3MPa{3.06kgf/cm ² }	0.3MPa{3.06kgf/cm ² }	
Load Pressure Coefficient	At least 95%		
Allowable Maximum Speed	18m/min		
Allowable Minimum Speed	0.3m/min		
Cylinder Inside Diameter (mm)	30, 40, 50, 63, 80, 100, 125, 140 150, 160, 180, 200, 224, 250		
Stroke	Standard up to 1000mm.		See page K-2 for strokes greater than 1000mm.
Rod Diameter	See JIS B8354 Table 5, Series B and C.		
Operating Fluid and Fluid Temperature	Operating Fluid : Mineral oil hydraulic fluid Oil Temperature : -10°C to 80°C		Fire resistant hydraulic fluid is also handled as standard products. Contact your agent for more information.
Paint Color	Mancel No 5B 6/3 Melamin No. 51		Or red rust-resistant paint

Note) Contact your agent for non-standard requirements.

The following series are also available.

- FH Series (21MPa)
- FJS Series (with switch)
- FL Series (3.5MPa)
- FJM Series (Mill)

Cylinder Specifications (Major Characteristics Calculated Values)

		Cylinder Inside Diameter mm															
		30	40	50	63	80	100	125	140	150	160	180	200	224	250		
Major Characteristics																	
Port Diameter Rc (Previously PT)		3/8	3/8	1/2	1/2	3/4	3/4	1	1	1	1	1 1/4	1 1/2	1 1/2	2		
Head Side Area (cm ²)		7	12.5	19.6	31.1	50.2	78.5	122.7	153.9	176.7	201	254.4	314.1	394	490.8		
Rod Diameter Series B	Rod Diameter (mm)	18	22.4	28	35.5	45	56	71	80	85	90	100	112	125	140		
	Rod Side Area (cm ²)	4.5	8.6	13.5	21.3	34.3	53.9	83.2	103.7	120	137.4	175.9	215.6	271.3	336.9		
	Rod Area (cm ²)	2.5	3.9	6.1	9.8	15.9	24.6	39.5	50.2	56.7	63.6	78.5	98.5	122.7	153.9		
	Speed Ratio	Forward	1	1	1	1	1	1	1	1	1	1	1	1	1	1	
		Reverse	1.55	1.45	1.45	1.46	1.46	1.45	1.47	1.48	1.47	1.46	1.44	1.45	1.45	1.45	
	Output kN (kgf)	7MPa {71.4kgf/cm ² }	Forward	4.90 {500}	8.75 {893}	13.72 {1400}	21.77 {2221}	35.14 {3584}	54.95 {5605}	85.89 {8761}	107.73 {10988}	123.69 {12616}	140.70 {14351}	178.08 {18164}	219.87 {22427}	275.80 {28132}	343.56 {35043}
			Reverse	3.15 {321}	6.02 {614}	9.45 {964}	14.91 {1521}	24.01 {2449}	37.73 {3848}	58.24 {5940}	72.59 {7404}	84.00 {8568}	96.18 {9810}	123.13 {12559}	150.92 {15394}	189.91 {19371}	235.83 {24055}
		14MPa {143kgf/cm ² }	Forward	9.80 {1001}	17.50 {1788}	27.44 {2803}	43.54 {4447}	70.28 {7179}	109.90 {11226}	171.78 {17546}	215.46 {22008}	247.38 {25268}	281.40 {28743}	356.16 {36379}	439.74 {44916}	551.60 {56342}	687.12 {70184}
			Reverse	6.30 {644}	12.04 {1230}	18.90 {1931}	29.82 {3046}	48.02 {4905}	75.46 {7708}	116.48 {11898}	145.18 {14829}	168.00 {17160}	192.36 {19648}	246.26 {25154}	301.84 {30831}	379.82 {38796}	471.66 {48177}
	Rod Diameter Series C	Rod Diameter (mm)	-	18	22.4	28	35.5	45	56	63	67	-	-	-	-	-	
Rod Side Area (cm ²)		-	10	15.7	25	40.4	62.6	98.1	122.8	141.5	-	-	-	-	-		
Rod Area (cm ²)		-	2.5	3.9	6.1	9.8	15.9	24.6	31.1	35.2	-	-	-	-	-		
Speed Ratio		Forward	-	1	1	1	1	1	1	1	1	-	-	-	-	-	
		Reverse	-	1.25	1.24	1.24	1.24	1.25	1.25	1.25	1.24	-	-	-	-	-	
Output kN (kgf)		7MPa {71.4kgf/cm ² }	Forward	-	8.75 {893}	13.72 {1400}	21.77 {2221}	35.14 {3584}	54.95 {5605}	85.89 {8761}	107.73 {10988}	123.69 {12616}	-	-	-	-	
			Reverse	-	7.00 {714}	10.99 {1121}	17.50 {1785}	28.28 {2885}	43.82 {4470}	68.67 {7004}	85.96 {8768}	99.05 {10103}	-	-	-	-	
		14MPa {143kgf/cm ² }	Forward	-	17.50 {1788}	27.44 {2803}	43.54 {4447}	70.28 {7179}	109.90 {11226}	171.78 {17546}	215.46 {22008}	247.38 {25268}	-	-	-	-	
			Reverse	-	14.00 {1430}	21.98 {2245}	35.00 {3575}	56.56 {5777}	87.64 {8952}	137.34 {14028}	171.92 {17560}	198.10 {20235}	-	-	-	-	
Cushion Stroke (mm)		-		20				25					30		35		

Note) 1.Non-cushion (N) is standard for inside diameter φ30. Contact your agent for information about cushions.



2.Speed ratio and out output specifications are theoretical values based on a JIS B8354 rod diameter.

Understanding Model Numbers

FJ - FA N 1 J 100 B 1000 T R - 21

Cylinder name _____
 Mounting _____

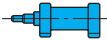
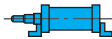
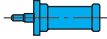
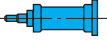
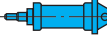
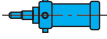
Design number
 Cushion, air bleeder position
 Port position

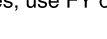
LA type	Axial right-angle foot type	
*LB type	Axial foot type	
*FA type	Rod side flange type	
*FY type	Head side flange type	
*FB type	Head side flange type	
*FZ type	Head side flange type	
CA type	Rear clevis type	
TA type	Rod side trunnion type	
TC type	Intermediate trunnion type	

*LB, FA, and FB types are for 7Mpa {71.4kgf/cm²} high operating pressure types in accordance with JIS B8354. For flange types under higher pressures, use FY or FZ.

Cushioning _____

N	None
H	Head side cushioning
R	Rod side cushioning
B	Both side cushioning

Pressure classification _____

1	Maximum operating pressure: 7MPa{71.4kgf/cm ² }
2	Maximum operating pressure: 14MPa{143kgf/cm ² }

Bellows _____

A	Conex
C	Silicon
J	Nylon/tarpaulin (standard)
K	Neoprene
None	None

Cylinder I.D. _____

Rod diameter sequence (B, C) _____

Cylinder stroke _____

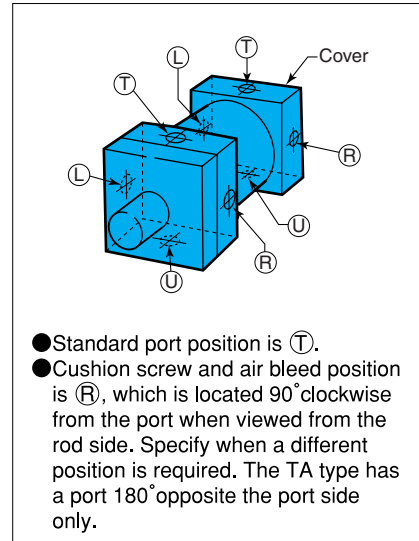

Stroke up to 1000mm is standard. See the following table for strokes greater than 1000mm.

Series Inside diameter	30 · 40		50 to 150		180 to 250	
	7MPa{71.4kgf/cm ² }	1500	2000	1500	1501 to 2000	
14MPa{143kgf/cm ² }	1500	2000	800	801 to 2000		
Cover Fixing System	Tie Rod			Screw In Flange		

Note) 1. Use a Nomograph to determine rod buckling.
 2. With the screw in flange system, the tube and flange are fixed by being screwed in.

● Handling

Note the following installation and handling precautions to get the most out of cylinder performance and to obtain the long service life for which cylinders are designed.

- 1] Cylinders are designed for rigidity. Be sure to secure them in place with bolts.
- 2] Install cylinders in a location that allows their easy removal, maintenance, and inspection.

- 3] When installing a cylinder in a location where the air quality is poor, or where there are large amounts of dust, metal powder, or other contaminants, install dust covers on the rod and shell to protect them.
- 4] When installing a cylinder, align it with the center of the slide, and make sure it is not subjected to lateral or rotational force by the piston or rod. When lateral force is

unavoidable, make sure it does not exceed 1/100 of cylinder maximum output.

- 5] When coupling the piston rod and machinery, adjust so there is no unnecessary force applied to the piston rod sliding bush.
- 6] For other details, see catalog number 9214.

Nomograph

(Operation Conditions, Load, Rod, Stroke)

- Back Ring Safety Factor 4 According to Euler Equation

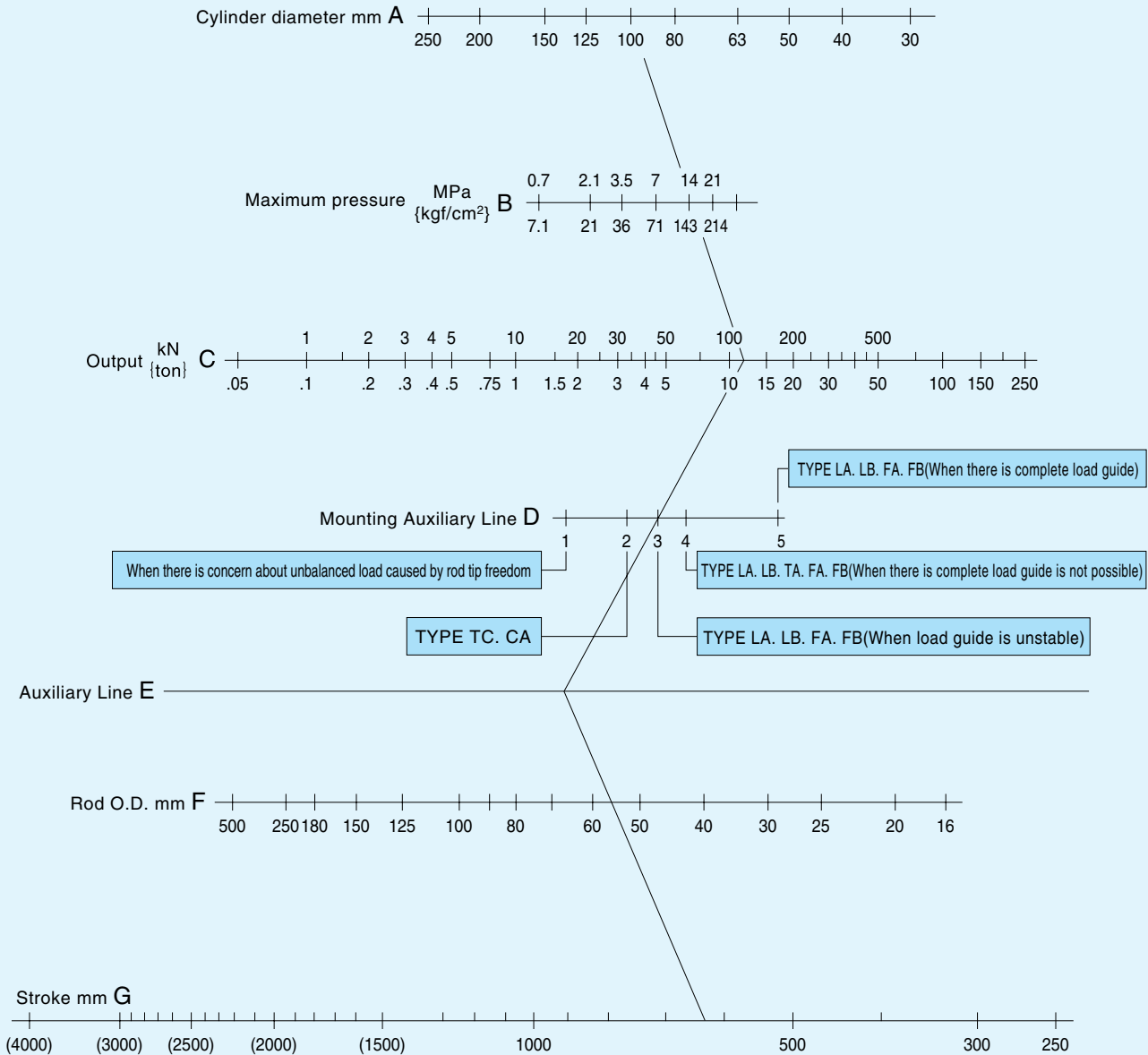

Note) TC type is intermediate trunnion type

- Nomograph Application Example
 - Determining Maximum Stroke
- The maximum stroke under the following operating conditions can be easily determined as shown below.

Operating Environment

- Cylinder I.D. : $\phi 100\text{mm}$
- Maximum Working Pressure: 14MPa{143kgf/cm²}
- Mounting Method : FA type (Rod Side Flange)
- Load Guide Condition : Unstable
- Piston Rod Diameter : 56mm

Determining Maximum Stroke

- 1 Draw a line through 100mm on Line A (Cylinder I.D.) and 14 on Line B (Maximum Pressure), and extend it to Line C (Output). The point of intersection on Line C is at 110kN.
- 2 Draw a line from 100kN on Line C to point 3 (FA type, unstable load guide) on Line D (Mounting Type Auxiliary Line), and then extend the line until it intersects with Line E.
- 3 Draw a line from the point of intersection on Line E to 56mm on Line F (Rod Diameter) and then extend the line until it intersects with Line G (Stroke). This indicates a maximum stroke of about 630mm.

Installation Dimension Drawings

LA Type 7MPa{71.4kgf/cm²}.14MPa{143kgf/cm²}

LB Type 7MPa{71.4kgf/cm²}

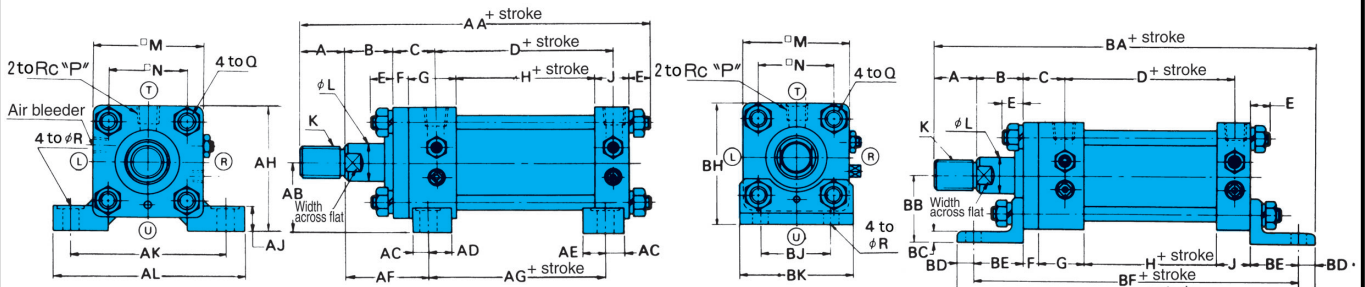

FA Type 7MPa{71.4kgf/cm²}

FB Type 7MPa{71.4kgf/cm²}

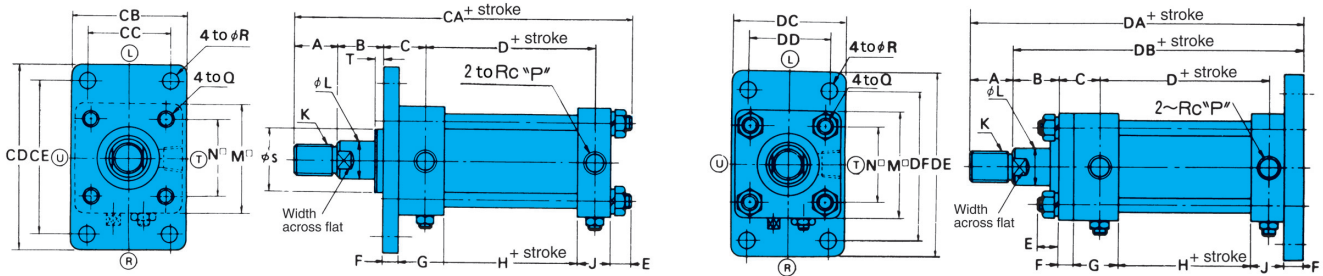

CA Type 7MPa{71.4kgf/cm²}.14MPa{143kgf/cm²}

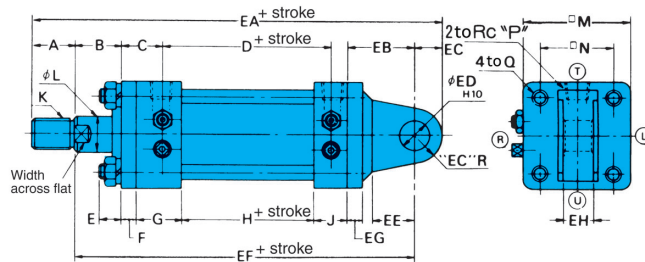

TA Type 7MPa{71.4kgf/cm²}.14MPa{143kgf/cm²}

TC Type 7MPa{71.4kgf/cm²}.14MPa{143kgf/cm²}

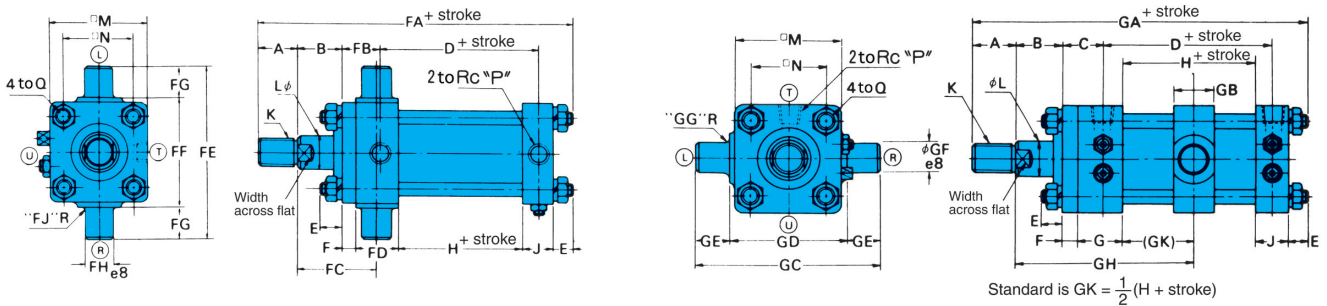

FY Type 7MPa{71.4kgf/cm²}.14MPa{143kgf/cm²}

FZ Type 7MPa{71.4kgf/cm²}.14MPa{143kgf/cm²}

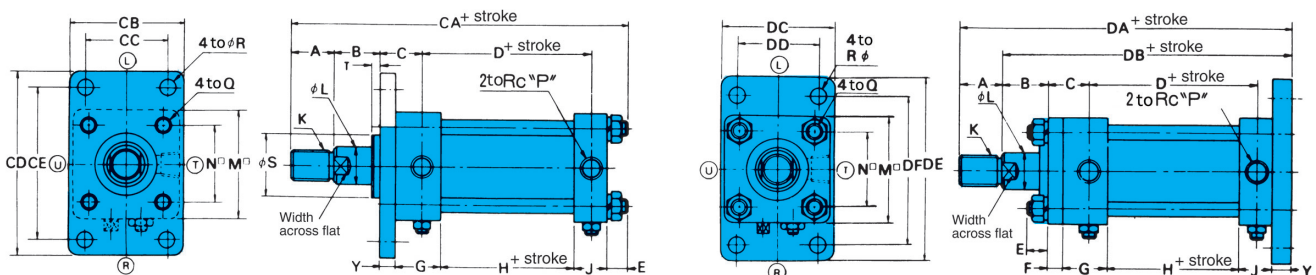

K Hydraulic Cylinder

Symbol		Inside diameter																
		30	40	50	63	80	100	125	140	150	160	180	200	224	250			
Common	Rod diameter	Series B	A	25	30	35	45	60	75	95	110	115	120	140	150	180	195	
			※ S	36	40	46	55	65	80	95	105	110	115	125	140	150	170	
			※ T	10	10	10	10	10	10	10	10	10	10	10	10	10	10	10
			K	M16 P1.5	M20 P1.5	M24 P1.5	M30 P1.5	M39 P1.5	M48 P1.5	M64 P2	M72 P2	M76 P2	M80 P2	M95 P2	M100 P2	M120 P2	M130 P2	
			L	18	22.4	28	35.5	45	56	71	80	85	90	100	112	125	140	
		Width across flat	14	19	24	30	41	50	65	75	80	85	95	105	115	130		
		Series C	A	—	25	30	35	45	60	75	80	85	—	—	—	—	—	
			※ S	—	36	40	46	55	65	80	85	90	—	—	—	—	—	
			※ T	—	10	10	10	10	10	10	10	10	—	—	—	—	—	
			K	—	M16 P1.5	M20 P1.5	M24 P1.5	M30 P1.5	M39 P1.5	M48 P1.5	M56 P2	M60 P2	—	—	—	—	—	
	L		—	18	22.4	28	35.5	45	56	63	67	—	—	—	—	—		
	Width across flat	—	14	19	24	30	41	50	55	60	—	—	—	—	—			
	B	30	30	30	35	35	40	45	50	50	55	55	55	60	65			
	C	38	38	42	46	56	58	67	69	71	74	75	85	89	106			
	C(FY Type only)	40	40	47	51	62	66	76	80	82	84	88	99	106	125			
	D	90	90	98	102	110	116	130	138	146	156	172	184	184	200			
	E	11	13	13	16	20	24	26	28	31	31	34	38	45	50			
	H	60	60	64	68	70	76	80	88	96	104	86	90	90	90			
	J	28	28	32	32	38	38	48	48	48	49	71	79	79	95			
	M	55	65	75	90	110	135	165	185	196	210	235	262	292	325			
	N	40	46	54	66	82	100	126	138	150	160	182	200	225	250			
	P	3/8	3/8	1/2	1/2	3/4	3/4	1	1	1	1	1 1/4	1 1/2	1 1/2	2			
	Q	M8 P1.25	M10 P1.5	M10 P1.5	M12 P1.5	M16 P1.5	M18 P1.5	M22 P1.5	M24 P1.5	M27 P1.5	M27 P1.5	M30 P1.5	M33 P1.5	M39 P1.5	M42 P1.5			
	F	11	11	13	15	18	20	24	26	28	31	33	37	41	46			
	G	42	42	46	48	58	58	68	68	68	69	85	95	95	115			
R	11	11	14	18	18	22	26	26	30	33	33	36	42	45				
Y	13	13	18	20	24	28	33	37	39	41	46	51	58	65				
LA Type	AA	207	214	233	259	299	331	386	418	436	459	504	544	590	656			
	AB	35	37.5	45	50	60	71	85	95	106	112	125	140	150	170			
	AC	13	13	14	18	18	22	25	25	28	31	35	39	39	47			
	AD	31	31	34	32	42	38	41	41	38	40	50	56	56	68			
	AE	31	31	34	32	42	38	41	41	38	40	36	40	40	48			
	AF	57	57	60	71	74	85	99	106	111	122	123	131	140	158			
	AG	98	98	108	106	124	122	136	144	146	150	172	186	186	206			
	AH	62.5	70	82.5	95	115	138.5	167.5	187.5	204	217	242.5	271	296	332.5			
	AJ	14	14	17	19	25	27	32	35	37	42	47	52	52	57			
	AK	88	95	115	132	155	190	224	250	270	285	315	355	395	425			
	AL	109	118	145	165	190	230	272	300	320	345	375	425	475	515			
	LB Type	BA	241	246	270	303	349	385	455	490	510	538	595	644	705	786		
BB		40	43	50	60	72	85	105	115	123	132	148	165	185	208			
BC		8	8	8	10	12	12	15	18	18	18	20	25	30	35			
BD		13	13	15	18	20	23	29	30	30	35	40	40	45	50			
BE		32	32	35	42	50	55	66	70	75	75	85	98	115	130			
BF		205	205	225	247	284	302	352	370	390	403	445	497	535	606			
BG		231	231	255	283	324	348	410	430	450	473	525	577	625	706			
BH		67.5	75.5	87.5	105	127	152.5	187.5	207.5	221	237	265.5	296	331	370.5			
BJ		40	46	58	65	87	109	130	145	155	170	185	206	230	250			
BK		63	69	85	98	118	150	175	195	210	225	243	272	310	335			
FA FY Type		CA(FA Type)	207	214	233	259	299	331	386	418	436	459	504	544	590	656		
	CA(FY Type)	209	216	238	264	305	339	395	429	447	469	517	558	607	675			
	CB	63	69	85	98	118	150	175	195	210	225	243	272	310	335			
	CC	40	46	58	65	87	109	130	145	155	170	185	206	230	250			
	CD	109	118	145	165	190	230	272	300	320	345	375	425	475	515			
	CE	88	95	115	132	155	190	224	250	270	285	315	355	395	425			
FB FZ Type	DA(FB Type)	207	212	233	258	297	327	384	416	433	459	503	543	586	652			
	DA(FZ Type)	209	214	238	263	303	335	393	427	444	469	516	557	603	671			
	DB(FB Type)	182	182	198	213	237	252	289	306	318	339	363	393	406	457			
	DB(FZ Type)	184	184	203	218	243	260	298	317	329	349	376	407	423	476			
	DC	63	69	85	98	118	150	175	195	210	225	243	272	310	335			
	DD	40	46	58	65	87	109	130	145	155	170	185	206	230	250			
	DE	109	118	145	165	190	230	272	300	320	345	375	425	475	515			
	DF	88	95	115	132	155	190	224	250	270	285	315	355	395	425			

Unit : mm

		Inside diameter													
Symbol		34	40	50	63	80	100	125	140	150	160	180	200	224	250
CA Type	EA	250	255	285	337.5	382.5	431	510	573	590	636	700	766	830	891
	EB	38	38	45	63	72	84	100	120	122	137	150	170	185	185
	EC	16	16	20	31.5	31.5	40	50	63	63	71	80	90	100	100
	ED	16	16	20	31.5	31.5	40	50	63	63	71	80	90	100	100
	EE	20	20	25	40	40	50	63	80	80	90	100	115	125	125
	EF	209	209	230	261	291	316	365	400	412	445	480	526	550	596
	EG	12	12	14	17	20	23	27	25	32	33	35	37	41	45
	EH	25 ^{-0.1} _{-0.4}	25 ^{-0.1} _{-0.4}	31.5 ^{-0.1} _{-0.4}	40 ^{-0.1} _{-0.4}	40 ^{-0.1} _{-0.4}	50 ^{-0.1} _{-0.4}	63 ^{-0.1} _{-0.4}	80 ^{-0.1} _{-0.6}	80 ^{-0.1} _{-0.6}	80 ^{-0.1} _{-0.6}	100 ^{-0.1} _{-0.6}	125 ^{-0.1} _{-0.6}	125 ^{-0.1} _{-0.6}	125 ^{-0.1} _{-0.6}
TA Type	FA	207	214	233	259	299	331	386	418	436	469	504	544	600	656
	FB	38	38	42	46	56	58	67	69	71	84	75	85	99	106
	FC	62	62	66	74	82	89	103	112	112	126	130.5	139.5	153.5	168.5
	FD	42	42	46	48	58	58	68	68	68	79	85	95	105	115
	FE	98	109	135	161	181	225	275	321	332	360	403	452	500	535
	FF	58 ⁰ _{-0.5}	69 ⁰ _{-0.5}	85 ⁰ _{-0.5}	98 ⁰ _{-0.5}	118 ⁰ _{-0.5}	145 ⁰ _{-0.5}	175 ⁰ _{-0.5}	195 ⁰ _{-0.5}	206 ⁰ _{-0.5}	218 ⁰ _{-0.5}	243 ⁰ _{-0.5}	272 ⁰ _{-0.5}	300 ⁰ _{-0.5}	335 ⁰ _{-0.5}
	FG	20	20	25	31.5	31.5	40	50	63	63	71	80	90	100	100
	FH	20 ^{-0.040} _{-0.073}	20 ^{-0.040} _{-0.073}	25 ^{-0.040} _{-0.073}	31.5 ^{-0.050} _{-0.089}	31.5 ^{-0.050} _{-0.089}	40 ^{-0.050} _{-0.089}	50 ^{-0.050} _{-0.089}	63 ^{-0.060} _{-0.106}	63 ^{-0.060} _{-0.106}	71 ^{-0.060} _{-0.106}	80 ^{-0.060} _{-0.106}	90 ^{-0.072} _{-0.126}	100 ^{-0.072} _{-0.126}	100 ^{-0.072} _{-0.126}
FJ	2	2	2.5	2.5	2.5	3	3	4	4	4	4	5	5	5	
TC Type	GA	207	214	233	259	299	331	386	418	436	459	504	544	590	656
	GB	28	28	33	43	43	53	58	78	78	88	98	108	117	117
	GC	98	109	135	161	181	225	275	321	332	360	403	452	500	535
	GD	58 ⁰ _{-0.5}	69 ⁰ _{-0.5}	85 ⁰ _{-0.5}	98 ⁰ _{-0.5}	118 ⁰ _{-0.5}	145 ⁰ _{-0.5}	175 ⁰ _{-0.5}	195 ⁰ _{-0.5}	206 ⁰ _{-0.5}	218 ⁰ _{-0.5}	243 ⁰ _{-0.5}	272 ⁰ _{-0.5}	300 ⁰ _{-0.8}	335 ⁰ _{-0.8}
	GE	20	20	25	31.5	31.5	40	50	63	63	71	80	90	100	100
	GF	20 ^{-0.040} _{-0.073}	20 ^{-0.040} _{-0.073}	25 ^{-0.040} _{-0.073}	31.5 ^{-0.050} _{-0.089}	31.5 ^{-0.050} _{-0.089}	40 ^{-0.050} _{-0.089}	50 ^{-0.050} _{-0.089}	63 ^{-0.060} _{-0.106}	63 ^{-0.060} _{-0.106}	71 ^{-0.060} _{-0.106}	80 ^{-0.060} _{-0.106}	90 ^{-0.072} _{-0.126}	100 ^{-0.072} _{-0.126}	100 ^{-0.072} _{-0.126}
	GG	2	2	2.5	2.5	2.5	3	3	4	4	4	4	5	5	5
	☆ GH	113+ ST ₂	113+ ST ₂	121+ ST ₂	132+ ST ₂	146+ ST ₂	156+ ST ₂	177+ ST ₂	188+ ST ₂	194+ ST ₂	207+ ST ₂	216+ ST ₂	232+ ST ₂	241+ ST ₂	271+ ST ₂

☆ : Specify when GH dimensions are different from those shown above.

Note) 1.ST is stroke.

2.The overall length dimensions are B Series dimensions. For Series C, Dimension A is different, so overall length is also different.

3.S and T rows marked with an asterisk (*) are FY type typical values. See FY Type for other types of mounting.

• Weight Table

Unit : kg

		Cylinder I.D.														
Model No.		30	40	50	63	80	100	125	140	150	160	180	200	224	250	
Rod Diameter Series B	Weight at Zero Stroke	LA	3.8	4.2	6.0	9.3	17.8	27.7	46.7	67.3	75.3	94.7	122.8	168.2	229.5	304.2
		LB	4	4.4	6.3	9.9	18.2	29.0	49.7	69.2	80.6	98.3	126.7	171.3	232.0	309.2
		FA	3.7	4.1	6.3	9.6	17.0	26.7	48.4	66.4	74.2	94	122.6	163.3	207.5	284.0
		FY	3.8	4.2	6.8	10.3	18.0	28.9	51.8	71.4	80.0	100.1	131.9	176.0	227.2	309.8
		FB	4.1	4.5	6.9	10.6	18.6	29.4	53.2	73.7	82.5	105.33	136.3	182.7	243.0	322.2
		FZ	4.2	4.6	7.4	11.3	19.6	31.6	56.6	78.7	88.3	111.4	145.6	195.4	262.7	348.0
		CA	4.2	4.6	7.0	11.1	18.9	31.1	56.5	78.6	88.0	110.8	151.0	203.6	267.3	339.2
		TA	3.6	4.0	6.2	9.4	16.6	26.3	48.0	66.2	73.7	92.9	121.9	162.7	206.0	281.5
		TC	4.1	4.5	6.6	10.6	18.0	28.5	51.3	74	79.8	103.7	133.8	180.2	236.0	309.2
	Weight at 100mm Stroke	0.8	1.1	1.4	2.2	3.4	4.9	7.9	10	12.2	13.1	17.4	21.4	27.2	33.6	
Rod Diameter Series C	Weight at Zero Stroke	LA	-	4.1	5.8	8.8	16.9	26.3	43.8	63.3	70.7	-	-	-	-	-
		LB	-	4.3	6.1	9.4	17.3	27.6	46.8	65.2	76	-	-	-	-	-
		FA	-	4.0	6.1	9.1	16.1	25.3	45.5	62.4	69.6	-	-	-	-	-
		FY	-	4.1	6.6	9.8	17.1	27.5	48.9	77.4	75.4	-	-	-	-	-
		FB	-	4.4	6.7	10.1	17.7	28	50.3	69.7	77.9	-	-	-	-	-
		FZ	-	4.5	7.2	10.8	18.7	30.2	53.7	74.7	83.7	-	-	-	-	-
		CA	-	4.5	6.8	10.6	18	29.7	53.6	74.6	83.4	-	-	-	-	-
		TA	-	3.9	6.0	8.9	15.7	24.9	45.1	62.2	69.1	-	-	-	-	-
		TC	-	4.4	6.4	10.1	17.1	27.1	48.4	70	75.2	-	-	-	-	-
	Weight at 100mm Stroke	-	1.0	1.2	1.9	2.9	4.2	6.7	8.5	10.5	-	-	-	-	-	

Note) Cylinder weight is the total of the zero stroke weight plus the stroke weight.

K

Hydraulic Cylinder

● Rod Cover Mounting Method

Symbol		Inside diameter													
		30	40	50	63	80	100	125	140	150	160	180	200	224	250
W ₁	B	50	50	60	70	80	100	120	130	140	140	150	170	180	200
	C	—	50	50	60	70	80	100	120	130	—	—	—	—	—
W ₂		20	20	20	30	30	30	40	40	40	40	40	40	50	50
W ₃		45 + $\frac{ST}{3.5}$	45 + $\frac{ST}{3.5}$	45 + $\frac{ST}{3.5}$	55 + $\frac{ST}{4}$	55 + $\frac{ST}{4}$	55 + $\frac{ST}{4}$	65 + $\frac{ST}{5}$	65 + $\frac{ST}{5}$	65 + $\frac{ST}{5}$	65 + $\frac{ST}{5}$	65 + $\frac{ST}{5}$	65 + $\frac{ST}{5}$	80 + $\frac{ST}{6}$	80 + $\frac{ST}{6}$

ST is stroke.

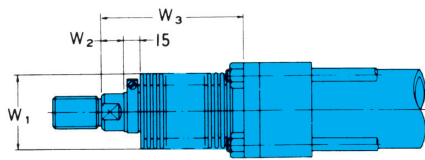

- Note) 1.The decimal part of the W₃ dimension is rounded down.
 2.This diagram shows dimensions for nylon tarpaulin (Standard: 80°C max. heat resistance), neoprene (130°C max. heat resistance), silicon (220°C max. heat resistance), and conex (300°C max. heat resistance), which are used with the standard FJ cylinder. Heat resistance does not indicate constant temperature, but maximum temperature within a short period. Asbestos/aluminum (400°C max. heat resistance) and other materials are also available, and using such materials changes the W₃ dimension. Contact your agent for more information.
 3.Use a heat wall when there is particularly intense heat radiation due to ambient temperature. Also avoid high temperatures due to heat conduction.
 4.When a rod cover is required, specify with the symbol described in the section that explains model numbers.

● Packing Type List

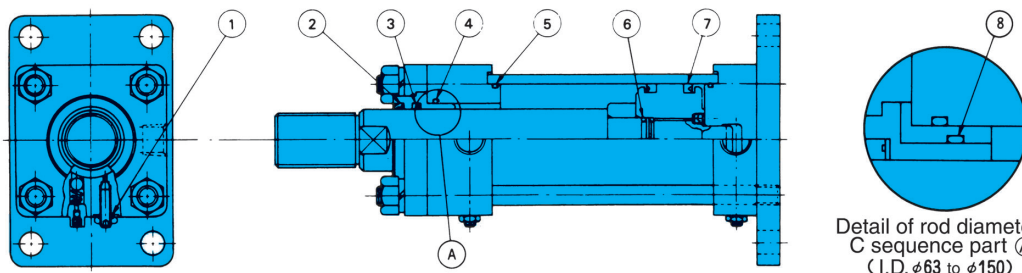

Note)O-ring 1A/B-** refers to JIS B2401-1A/B.

Rod Diameter Series B

Part No.	1	2	3	4	5	6	7
Cylinder	Cushion Valve Nominal Diameter Screw Seat Packing (Fujikoshi)(Qty : 2)	Dust Seal SDR Type I.D. × O.D. × Height (Qty : 1)	Gland Packing SKY Type I.D. × O.D. × Height (Qty : 1)	Gland Bush Nominal Diameter (Qty : 1)	Cover Nominal Diameter (Qty : 2)	Piston I.D. Nominal Diameter (Qty : 1)	Piston Packing SKY Type I.D. × O.D. × Height (Qty : 2)
I.D.							
30	M10P1.5 × 3.5	18 × 26 × 4.5 × 6	18 × 26 × 5	1A-G30	1B-G25	1A-P14	22.4 × 30 × 5
40	M10P1.5 × 3.5	22.4 × 30.4 × 4.5 × 6	22.4 × 30 × 5	1A-G30	1B-G35	1A-P15	30 × 40 × 6
50	M10P1.5 × 3.5	28 × 36 × 4.5 × 6	28 × 35.5 × 5	1A-G35	1B-G45	1A-P20	40 × 50 × 6
63	M10P1.5 × 3.5	35.5 × 43.5 × 5 × 6.5	35.5 × 45 × 6	1A-G45	1B-G58	1A-G25	53 × 63 × 6
80	M10P1.5 × 3.5	45 × 53 × 5 × 6.5	45 × 55 × 6	1A-G55	1B-G75	1A-P32	71 × 80 × 6
100	M10P1.5 × 3.5	56 × 64 × 5 × 6.5	56 × 66 × 6	1A-G65	1B-G95	1A-G35	85 × 100 × 9
125	M10P1.5 × 3.5	71 × 81 × 6 × 8	71 × 80 × 6	1A-G80	1B-G120	1A-G45	112 × 125 × 8.5
140	M10P1.5 × 3.5	80 × 90 × 6 × 8	80 × 90 × 6	1A-G90	1B-G135	1A-G50	125 × 140 × 9
150	M10P1.5 × 3.5	85 × 95 × 6 × 8	85 × 100 × 9	1A-G95	1B-G145	1A-G55	136 × 150 × 8.5
160	M16P1.5 × 4.5	90 × 100 × 6 × 8	90 × 105 × 9	1A-G105	1B-G150	1A-G60	145 × 160 × 9
180	M16P1.5 × 4.5	100 × 110 × 6 × 8	100 × 115 × 9	1A-G115	1B-G170	1A-G70	165 × 180 × 9
200	M16P1.5 × 4.5	112 × 122 × 6 × 8	112 × 125 × 8.5	1A-G125	1B-G190	1A-G80	180 × 200 × 12
224	M16P1.5 × 4.5	125 × 138 × 7 × 9.5	125 × 140 × 9	1A-G140	1B-G214	1A-G90	204 × 224 × 12
250	M16P1.5 × 4.5	140 × 153 × 7 × 9.5	140 × 155 × 9	1A-G155	1B-G240	1A-G100	230 × 250 × 12

Rod Diameter Series C

Part No.	1	2	3	4	5	6	7	8
Cylinder	Cushion Valve Nominal Diameter Screw Seat Packing (Fujikoshi)(Qty : 2)	Dust Seal SDR Type I.D. × O.D. × Height (Qty : 1)	Gland Packing SKY Type I.D. × O.D. × Height (Qty : 1)	Gland Bush Nominal Diameter (Qty : 1)	Cover Nominal Diameter (Qty : 2)	Piston I.D. Nominal Diameter (Qty : 1)	Piston Packing SKY Type I.D. × O.D. × Height (Qty : 2)	Bush Nominal Diameter (Qty : 1)
I.D.								
40	M10P1.5 × 3.5	18 × 26 × 4.5 × 6	18 × 26 × 5	1A-G30	1B-35	1A-P15	30 × 40 × 6	—
50	M10P1.5 × 3.5	22.4 × 30.4 × 4.5 × 6	22.4 × 30 × 5	1A-G35	1B-45	1A-P20	40 × 50 × 6	—
63	M10P1.5 × 3.5	28 × 36 × 4.5 × 6	28 × 35.5 × 5	1A-G45	1B-58	1A-G25	53 × 63 × 6	1A-G35
80	M10P1.5 × 3.5	35.5 × 43.5 × 5 × 6.5	35.5 × 45 × 6	1A-G55	1B-75	1A-P32	71 × 80 × 6	1A-G45
100	M10P1.5 × 3.5	45 × 53 × 5 × 6.5	45 × 55 × 6	1A-G65	1B-95	1A-G35	85 × 100 × 9	1A-G55
125	M10P1.5 × 3.5	56 × 64 × 5 × 6.5	56 × 66 × 6	1A-G80	1B-120	1A-G45	112 × 125 × 8.5	1A-G65
140	M10P1.5 × 3.5	63 × 71 × 5 × 6.5	63 × 73 × 6	1A-G90	1B-135	1A-G50	125 × 140 × 9	1A-G75
150	M10P1.5 × 3.5	67 × 75 × 5 × 6.5	67 × 77 × 6	1A-G95	1B-145	1A-G55	136 × 150 × 8.5	1A-G80

• Tip Cap

FJI - 40 - B - 10

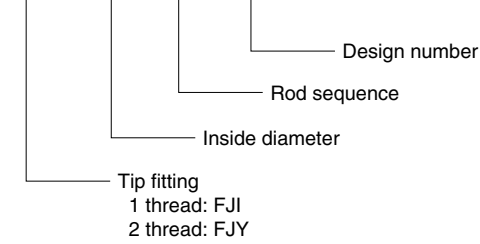

1-Fork Tip Cap

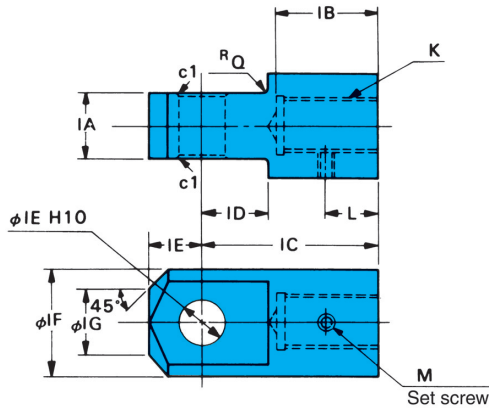

2-Fork Tip Cap (With Pin)

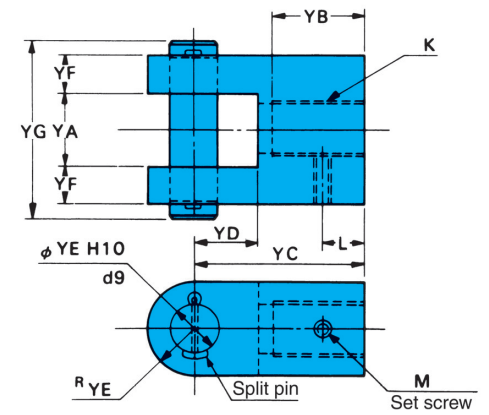

Locknut Type Description (Example)

FJN - 28 - 10

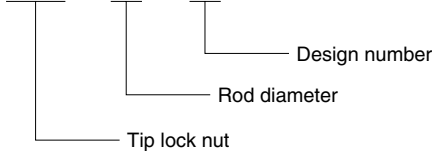

Locknut (For FJ)

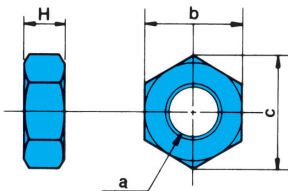

Symbol	Rod diameter										
	18	22.4	28	35.5	45	56	63	67	71	80	85
a	M16 P1.5	M20 P1.5	M24 P1.5	M30 P1.5	M39 P1.5	M48 P1.5	M56 P2	M60 P2	M64 P2	M72 P2	M76 P2
b	24	30	36	46	60	75	85	90	95	105	110
c	27.7	34.6	41.6	53.1	69.3	86.5	98.1	104	110	121	127
H	10	12	14	18	23	29	34	36	38	42	46

1-Fork Tip Cap

Symbol		Inside diameter									
		30	40	50	63	80	100	125	140	150	
Common	IA	25 ^{+0.1} _{-0.4}	25 ^{+0.1} _{-0.4}	31.5 ^{+0.1} _{-0.4}	40 ^{+0.1} _{-0.4}	40 ^{+0.1} _{-0.4}	50 ^{+0.1} _{-0.4}	63 ^{+0.1} _{-0.4}	80 ^{+0.1} _{-0.6}	80 ^{+0.1} _{-0.6}	
	IC	50	55	65	92	107	135	168	210	215	
	ID	20	20	25	40	40	50	63	80	80	
	IE	16	16	20	31.5	31.5	40	50	63	63	
	IF	35	35	45	65	65	85	105	130	130	
	IG	25	25	32	40	40	55	68	85	85	
	L	15	15	15	15	15	20	20	20	20	
	M	M8	M8	M8	M8	M8	M10	M10	M10	M10	
	Q	2	2	2.5	2.5	2.5	3	3	4	4	
Rod diameter	Series B	IB	27	32	37	47	62	78	98	113	118
	Series C	K	M16 P1.5	M20 P1.5	M24 P1.5	M30 P1.5	M39 P1.5	M48 P1.5	M64 P2	M72 P2	M76 P2
Rod diameter	Series B	IB	-	27	32	37	47	62	78	83	88
	Series C	K	-	M16 P1.5	M20 P1.5	M24 P1.5	M30 P1.5	M39 P1.5	M48 P1.5	M56 P2	M60 P2

2-Fork Tip Cap

Symbol		Inside diameter									
		30	40	50	63	80	100	125	140	150	
Common	YA	25 ^{+0.4} _{+0.1}	25 ^{+0.4} _{+0.1}	31.5 ^{+0.4} _{+0.1}	40 ^{+0.4} _{+0.1}	40 ^{+0.4} _{+0.1}	50 ^{+0.4} _{+0.1}	63 ^{+0.4} _{+0.1}	80 ^{+0.6} _{+0.1}	80 ^{+0.6} _{+0.1}	
	YC	50	55	65	92	107	135	168	210	215	
	YD	20	20	25	40	40	50	63	80	80	
	YE	16	16	20	31.5	31.5	40	50	63	63	
	YF	12.5	12.5	16	20	20	25	31.5	40	40	
	YG	66	66	80	101	101	126	153	192	192	
	L	15	15	15	15	15	20	20	20	20	
	M	M8	M8	M8	M8	M8	M10	M10	M10	M10	
	YB	27	32	37	47	62	78	98	113	118	
Rod diameter	Series B	YB	27	32	37	47	62	78	98	113	118
	Series C	K	M16 P1.5	M20 P1.5	M24 P1.5	M30 P1.5	M39 P1.5	M48 P1.5	M64 P2	M72 P2	M76 P2
Rod diameter	Series B	YB	-	27	32	37	47	62	78	83	88
	Series C	K	-	M16 P1.5	M20 P1.5	M24 P1.5	M30 P1.5	M39 P1.5	M48 P1.5	M56 P2	M60 P2