

- Flexible solution for complex breaker configurations
- Protection, metering, and control all in one
- CAN bus based communication
- Controls located near the breakers so less wiring required
- True RMS sensing
- Synch-check and dead bus functions
- Digital inputs for remote control
- PC and front panel configurable
- UL/cUL Listed
- Microprocessor technology for accurate, repeatable, and reliable operation

Generator Systems Solutions

**GCP-31 Control
LS 4 Control**

Generator Systems Solutions

GCP-31 & LS 4 Controls

Introduction

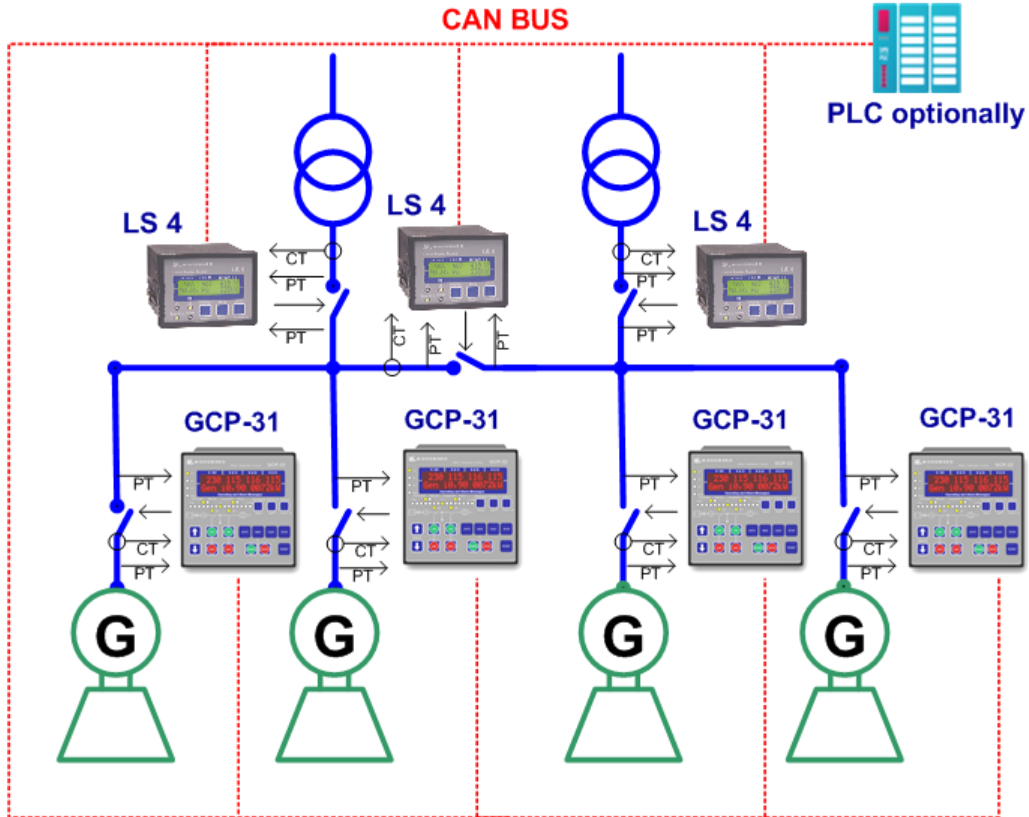

More information on the GCP-30 series and LS 4 is available on the Woodward website:

www.woodward.com

System Overview

Each generator set is controlled by a Woodward GCP-31, and each utility feed or tie breaker is controlled by an LS 4. Each of these devices communicates on the CAN bus network. This control system can be used for emergency standby applications and utility parallel applications.

For a standby system, the LS 4 recognizes that the utility breaker is closed and monitors the utility voltage to sense a failure. If either of the two utility feeds fails, the LS 4 unit sensing the failure sends a start command to the GCP-31 units. The GCP-31 control then starts the engines and closes the generator breakers to the generator bus.

If the tie breaker is open, the controls on either side function independently. If one of the utility feeds fails, only the generator sets on that side of the tie breaker are started for emergency operation. If the tie breaker is closed, all units will start. When the utility voltage returns, the LS 4 re-synchronizes the generators to the utility and closes the utility breaker.

For a continuous parallel application, the LS 4 is used to measure the power flow through the utility breaker for import/export control. The LS 4 communicates how much real power is flowing in or out of its feeder. The GCP-31 then operates in import or export control, varying the load on the generator.

Feature Overview

LS-4 Circuit breaker control



- Used for Tie Breakers and Utility Feeder Breakers
- A Local synchronizer and load transducer
- Communicates with the engine controls over a CAN bus network
- The user simply gives open or close commands to the unit and the LS-4 does the rest
- Safely handles dead bus closing
- Soft Unload feature for separating busses and utility feeds

GCP-31 Genset control package



- Complete Genset Control
- Engine Start/Stop Sequencing
- Engine Monitoring and Protection
- Generator Monitoring and Protection
- Synchronizer and Load Control
- Both Real and Reactive Load Control
- Used for Constant Baseload or Import Export Applications
- Simple to Operate from the unit pushbuttons

We appreciate your comments about the content of our publications.

Send comments to: icinfo@woodward.com

Please reference publication **51225**.



PO Box 1519, Fort Collins CO 80522-1519, USA
1000 East Drake Road, Fort Collins CO 80525, USA
Phone +1 (970) 482-5811 • Fax +1 (970) 498-3058

Email and Website—www.woodward.com

Woodward has company-owned plants, subsidiaries, and branches,
as well as authorized distributors and other authorized service and sales facilities throughout the world.

Complete address / phone / fax / email information for all locations is available on our website.