

# BATTERY CHARGING SET -BL 5

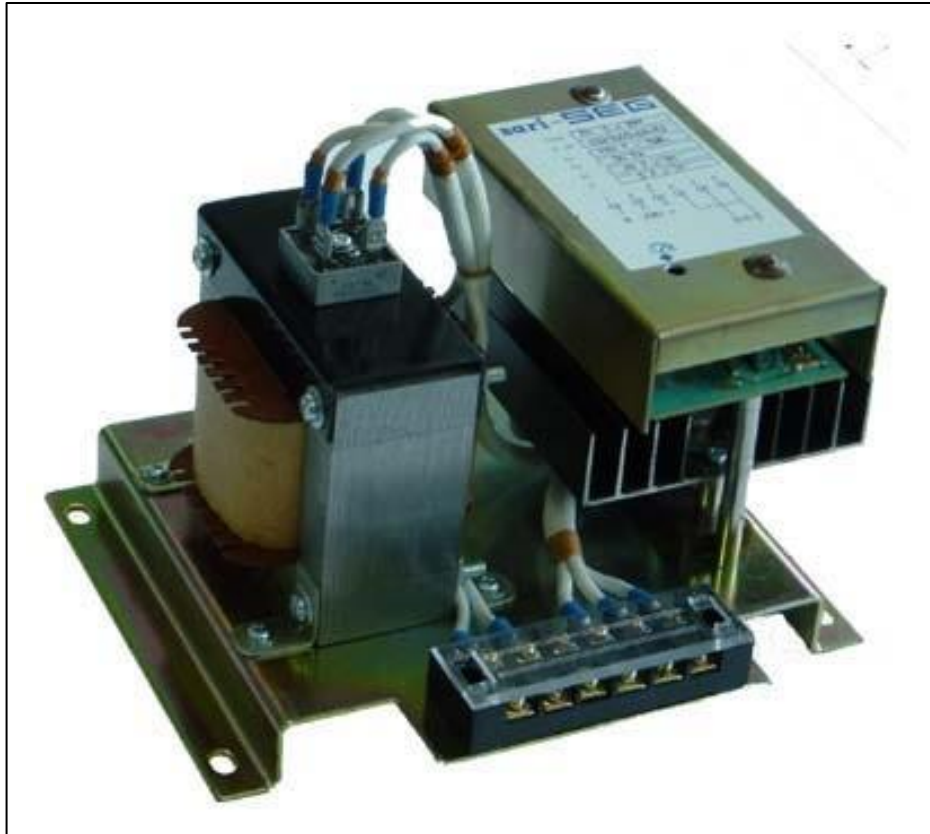

## Introduction

The charging set serves to recharge batteries rapidly and with less damage to the batteries, to maintain the fully - charged state of lead nickel – cadmium batteries and to cover the power requirement of continuous loads.

## Charging following the IE

### Characteristic curve

Depending upon the number of cells and the type of batteries, the charging set will charge until the full charge state is reached (for lead batteries 2.23V/Z, for NC batteries 1.4 V/Z, complying with VDE 051 or DIN 41 777) at the constant rate of 5 A. After this, the charge set supplies a lower trickle-charge current, dependent upon the charge voltage and, possibly, current for permanent loads. The charge set is short circuit proof, protected against incorrect polarity and requires no switching off, e.g. during starting the battery voltage breaks down owing to excessive power consumption.

### Equalizing charge following the I characteristic curve

Connecting the device terminals 4 and 6 via external normally-open contact permits an equalizing charge in excess of the fully-charge state.

NC batteries above all, require recharging up to 1.75 V/cell each time they become fully discharge in order to prevent a gradual loss of capacity. The equalizing charge is generally initiated manually.

Several charging sets may be arranged in parallel in order to produce higher currents. If this is done, you must ensure that the final charging voltage is the same setting on each charging set.

## Setting

Normal charge	: Disconnected terminal "6" and connect a voltmeter to terminal "5" and "6". Set potentiometers P2 so that the following appropriate final charge voltage is indicated.
12 V lead –Acid battery	: 13.5 V
24 V lead –Acid battery	: 27 V
12 V nickel cadmium batt.	: 14 V
24 V nickel cadmium batt.	: 26.6 V (19 cells)
24 V nickel cadmium batt.	: 28V (20 cells)
Equalizing charge	: The charging set is reconnected by terminals "4" and "6" to high charge. The charging set is preset at the factory to 16 or 32 Volts if necessary, this setting should be changed at potentiometer P3.

## Technical data

Type	: <b>BL 5 – 12,</b>	<b>BL 5 – 24</b>
Rated current	:	<b>5 A</b>
Rated voltage	: 12 V,	24 V
Input voltage	: 1 x 220 V	
Power consumption	: No - load - 50 VA, full - load - 300 VA	
Efficiency	: n = 0.86	

## Output voltage

Adjustment range		
Normal charge	: 12 V – 15 V,	24,5 V – 29,5 V
Equalizing charge	: 13 V	35 V

<b>Output Current</b>	: Maximum 5 A
Current Limiting	: Effective from 5 A upwards
Short-circuit behavior	: Device automatically switches off during short-circuit or incorrect polarity

## Charging characteristic curve

Normal charge	: I / E characteristic curve
Equalizing charge	: I characteristic curve
Permissible ambient Temperature	: - 25 <sup>0</sup> C to + 75 <sup>0</sup> C
Operating position	: Vertical, terminal box at bottom of unit
Useful life	: Virtually unlimited
Connection terminal	: M 3, maximum wire connection 2.5 mm
Permissible duty cycle	: 100 %
Weight	: 6.5 Kg
Maintenance	: No maintenance required

### Dimensions

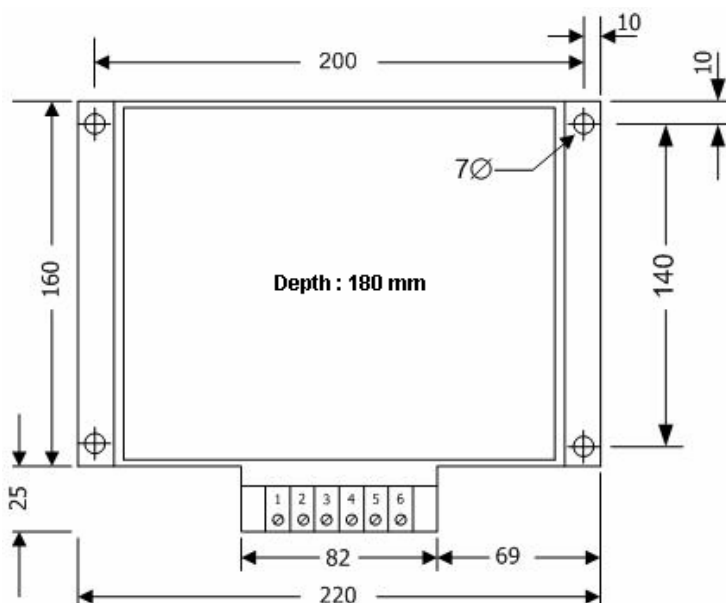

### Connection

