



Product Manual 04173
(Revision D, 4/2013)
Original Instructions

Flo-Tech™ Speed Control

Electronic Speed Control for Flo-Tech
UL/cUL Listed E97763

Installation and Operation Manual



General Precautions

Read this entire manual and all other publications pertaining to the work to be performed before installing, operating, or servicing this equipment.

Practice all plant and safety instructions and precautions.

Failure to follow instructions can cause personal injury and/or property damage.



Revisions

This publication may have been revised or updated since this copy was produced. To verify that you have the latest revision, check manual **26311**, *Revision Status & Distribution Restrictions of Woodward Technical Publications*, on the *publications* page of the Woodward website:

www.woodward.com/publications

The latest version of most publications is available on the *publications* page. If your publication is not there, please contact your customer service representative to get the latest copy.



Proper Use

Any unauthorized modifications to or use of this equipment outside its specified mechanical, electrical, or other operating limits may cause personal injury and/or property damage, including damage to the equipment. Any such unauthorized modifications: (i) constitute "misuse" and/or "negligence" within the meaning of the product warranty thereby excluding warranty coverage for any resulting damage, and (ii) invalidate product certifications or listings.



Translated Publications

If the cover of this publication states "Translation of the Original Instructions" please note:

The original source of this publication may have been updated since this translation was made. Be sure to check manual **26311**, *Revision Status & Distribution Restrictions of Woodward Technical Publications*, to verify whether this translation is up to date. Out-of-date translations are marked with . Always compare with the original for technical specifications and for proper and safe installation and operation procedures.

Revisions—Changes in this publication since the last revision are indicated by a black line alongside the text.

Woodward reserves the right to update any portion of this publication at any time. Information provided by Woodward is believed to be correct and reliable. However, no responsibility is assumed by Woodward unless otherwise expressly undertaken.

Contents

WARNINGS AND NOTICES	III
ELECTROSTATIC DISCHARGE AWARENESS	IV
CHAPTER 1. GENERAL INFORMATION.....	1
Introduction	1
Description	1
Accessories	2
References	3
CHAPTER 2. INSTALLATION.....	7
Introduction	7
Speed Control Installation	7
Magnetic Pickup	7
Wiring Instructions	8
CHAPTER 3. CALIBRATION AND OPERATION.....	11
Introduction	11
Signal Generator	11
Installation Checks	11
Initial Pre-Start Settings.....	12
Start-up Adjustments	13
Adjust for Stable Operation	13
Dynamic Adjustment.....	14
Start Fuel Limit	16
CHAPTER 4. DESCRIPTION OF OPERATION	17
Introduction	17
Electronic Circuits.....	17
Speed Control.....	17
Stability and Gain	17
Start Fuel Limit	17
Failed Speed Sensor	18
Auxiliary Input	18
Ramp Generator	18
Speed Trim	18
CHAPTER 5. TROUBLESHOOTING	19
Introduction	19
When the Governor is at Fault	19
Stability Problems.....	20
Magnetic Pickup	20
CHAPTER 6. PRODUCT SUPPORT AND SERVICE OPTIONS.....	21
Product Support Options	21
Product Service Options.....	21
Returning Equipment for Repair.....	22
Replacement Parts	22
Engineering Services.....	23
Contacting Woodward's Support Organization	23
Technical Assistance.....	24
REVISION HISTORY.....	25
DECLARATIONS.....	26

Illustrations and Tables

Figure 1-1. Flo-Tech Speed Control and Throttle Applied to a Gas Engine4
Figure 1-2. Flo-Tech Control Outline Drawing.....5
Figure 1-3. Plant Wiring Diagram6
Figure 3-1. Diesel Engine Response Curves15

Warnings and Notices

Important Definitions



This is the safety alert symbol. It is used to alert you to potential personal injury hazards. Obey all safety messages that follow this symbol to avoid possible injury or death.

- **DANGER**—Indicates a hazardous situation which, if not avoided, will result in death or serious injury.
- **WARNING**—Indicates a hazardous situation which, if not avoided, could result in death or serious injury.
- **CAUTION**—Indicates a hazardous situation which, if not avoided, could result in minor or moderate injury.
- **NOTICE**—Indicates a hazard that could result in property damage only (including damage to the control).
- **IMPORTANT**—Designates an operating tip or maintenance suggestion.

WARNING

**Overspeed /
Overtemperature /
Overpressure**

The engine, turbine, or other type of prime mover should be equipped with an overspeed shutdown device to protect against runaway or damage to the prime mover with possible personal injury, loss of life, or property damage.

The overspeed shutdown device must be totally independent of the prime mover control system. An overtemperature or overpressure shutdown device may also be needed for safety, as appropriate.

WARNING

**Personal Protective
Equipment**

The products described in this publication may present risks that could lead to personal injury, loss of life, or property damage. Always wear the appropriate personal protective equipment (PPE) for the job at hand. Equipment that should be considered includes but is not limited to:

- Eye Protection
- Hearing Protection
- Hard Hat
- Gloves
- Safety Boots
- Respirator

Always read the proper Material Safety Data Sheet (MSDS) for any working fluid(s) and comply with recommended safety equipment.

WARNING

Start-up

Be prepared to make an emergency shutdown when starting the engine, turbine, or other type of prime mover, to protect against runaway or overspeed with possible personal injury, loss of life, or property damage.

WARNING

**Automotive
Applications**

On- and off-highway Mobile Applications: Unless Woodward's control functions as the supervisory control, customer should install a system totally independent of the prime mover control system that monitors for supervisory control of engine (and takes appropriate action if supervisory control is lost) to protect against loss of engine control with possible personal injury, loss of life, or property damage.

NOTICE**Battery Charging
Device**

To prevent damage to a control system that uses an alternator or battery-charging device, make sure the charging device is turned off before disconnecting the battery from the system.

Electrostatic Discharge Awareness

NOTICE**Electrostatic
Precautions**

Electronic controls contain static-sensitive parts. Observe the following precautions to prevent damage to these parts:

- Discharge body static before handling the control (with power to the control turned off, contact a grounded surface and maintain contact while handling the control).
- Avoid all plastic, vinyl, and Styrofoam (except antistatic versions) around printed circuit boards.
- Do not touch the components or conductors on a printed circuit board with your hands or with conductive devices.

To prevent damage to electronic components caused by improper handling, read and observe the precautions in Woodward manual **82715**, *Guide for Handling and Protection of Electronic Controls, Printed Circuit Boards, and Modules*.

Follow these precautions when working with or near the control.

1. Avoid the build-up of static electricity on your body by not wearing clothing made of synthetic materials. Wear cotton or cotton-blend materials as much as possible because these do not store static electric charges as much as synthetics.
2. Do not remove the printed circuit board (PCB) from the control cabinet unless absolutely necessary. If you must remove the PCB from the control cabinet, follow these precautions:
 - Do not touch any part of the PCB except the edges.
 - Do not touch the electrical conductors, the connectors, or the components with conductive devices or with your hands.
 - When replacing a PCB, keep the new PCB in the plastic antistatic protective bag it comes in until you are ready to install it. Immediately after removing the old PCB from the control cabinet, place it in the antistatic protective bag.

Chapter 1.

General Information

Introduction

This manual is designed to provide the installer and operator of the Woodward Flo-Tech™ Speed Control the information needed to successfully install the speed control and to provide for operation, maintenance, and troubleshooting of the system.

Description

The Flo-Tech Speed Control is designed to provide basic isochronous speed control for gas engines using the Flo-Tech Throttle. Engines with mechanical loads and generator loads are handled equally well. Current and potential transformers and a Generator Load Sensor are required to control generator sets which will be paralleled.

Electronic Control

The Flo-Tech Speed Control is housed in a rugged aluminum casting which permits installation on the engine switch gear or generator panel. The electronics are not designed for installation directly on the engine.

The control is available for 12 or 24 Vdc power.

Idle and rated speed references may be set in the control. Rated speed is set with an internal 25-turn potentiometer between 3000 and 6000 Hz. Other ranges are available. (Hz is defined as the number of gear teeth the magnetic pickup will see during one complete revolution of the engine multiplied by the desired rpm divided by 60.)

$$Hz = \frac{\text{No. of teeth} \times RPM}{60}$$

Isochronous Speed Control

Isochronous control provided by the Flo-Tech Speed Control is always constant within the ability of the engine to carry the load. Multiple engine-generator systems supplying an isolated bus require a load sensor on each generator to provide isochronous load sharing throughout the system. Likewise, load sensors must be used if Flo-Tech-controlled engines are to be connected with a utility bus.

Start Fuel Limit

The adjustable start-fuel limit (cranking throttle) is set with a potentiometer on the control. The limit is automatically enabled whenever the engine shuts down. The limit is disabled when the engine reaches idle or rated speed as selected. If the start-fuel limit feature is not needed, the limit must be set fully clockwise so the fuel control output can go to maximum during start up. Start fuel limit can be adjusted to improve starting, decrease overfueling, and shorten cranking time.

Idle and Rated Speed and Dual Dynamics

Separate dynamics are available for idle and rated speeds as set in the electronic control. Idle speed is set with a separate potentiometer as a percentage of rated speed. The idle speed adjustment can be set between 25% and 100% of rated.

An external switch selects idle or rated dynamics. The switch may be arranged to be operated manually or through a generator breaker auxiliary contact. The idle dynamics are adjusted for the engine characteristic at idle speed unloaded. Rated dynamics are adjusted for the engine characteristics at rated speed or loaded. A common type of installation has the switch close when the engine-generator set is placed on line with a generator breaker closure. Rated dynamics are often set for best response when the engine is loaded. Idle dynamics are always set for best response when the engine is unloaded.

Providing different dynamics at the two selected speeds offers faster response at rated for better engine performance and smooth operating at idle for maximum efficiency and minimum fuel system wear.

Accessories

This manual contains some information about accessories often used with the Flo-Tech Speed Control.

DSLCTM Digital Synchronizer and Load Control

The DSLCTM control, when connected to each Flo-Tech Speed Control, provides an integrated means to automatically synchronize, control power and power factor, share load, and monitor multi-generator-set systems.

Generator Load Sensor

The Generator Load Sensor provides isochronous load sharing between engines in a multi-generator system by comparing the power output of the generator PT and CTs for each of the three phases from each system generator, and biasing the load sharing line network between the various Flo-Tech controlled engines to compensate for differences in load. The Load Sensor also provides a method to attach an SPM-A Synchronizer and other specialized control items to the generator control system. Generator droop operation can be achieved for infinite bus parallel operation and base loading.

SPM-A Synchronizer

The SPM-A Synchronizer, attached to the Flo-Tech system through a load sensor, will automatically bias the rated-speed setting until an engine/generator is in parallel with the bus. When the speed and generator phases are synchronized with the bus, the synchronizer will call for a breaker closure, smoothly and automatically connecting the generator with the bus.

Acceleration/Deceleration Ramp Generators

A Ramp Generator, or an external capacitor, can be used to increase the time to go from idle to rated speed and from rated speed to idle.

The 8271-909 Ramp Generator provides a linear ramp with times adjustable to 25 seconds in a typical case. Using a capacitor provides about one second of ramp time per 50 μF , 200 μF maximum.

References

Product Specifications

02006	<i>DSLDC Digital Synchronizer and Load Control</i>
82314	<i>Generator Load Sensor</i>
82380	<i>APTL Automatic Power Transfer and Load Control</i>
82399	<i>AGLC Automatic Generator Loading Control</i>
02010	<i>Magnetic Pickup</i>
82383	<i>SPM-A Synchronizer</i>

Publications may be ordered from any Woodward office. Woodward application engineers are also available to help you in the selection of the correct control for your system, or to answer questions concerning control installation, operation, or calibration.

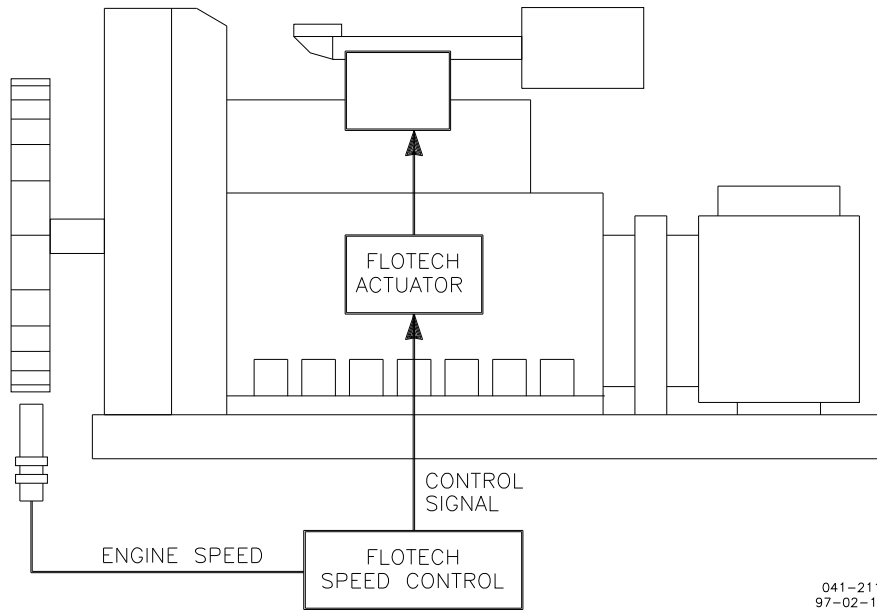
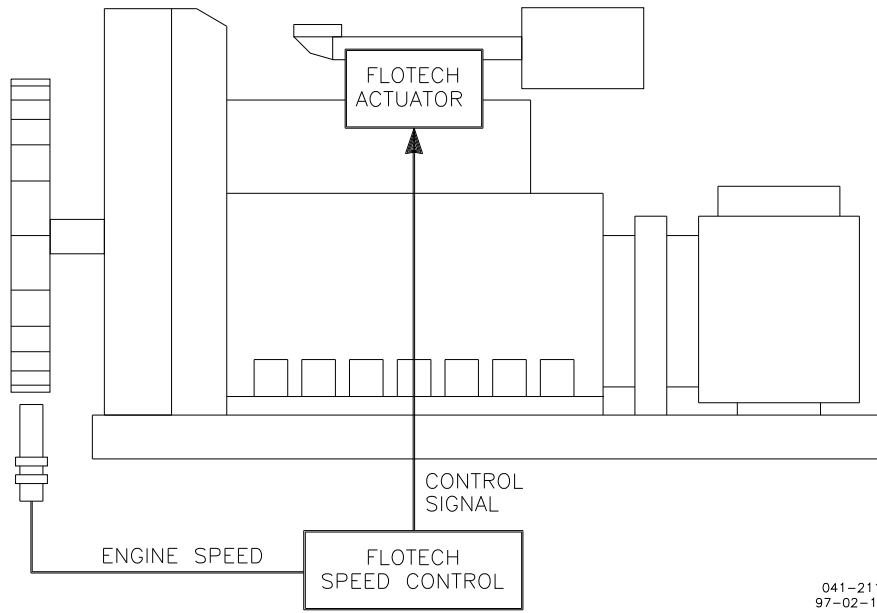
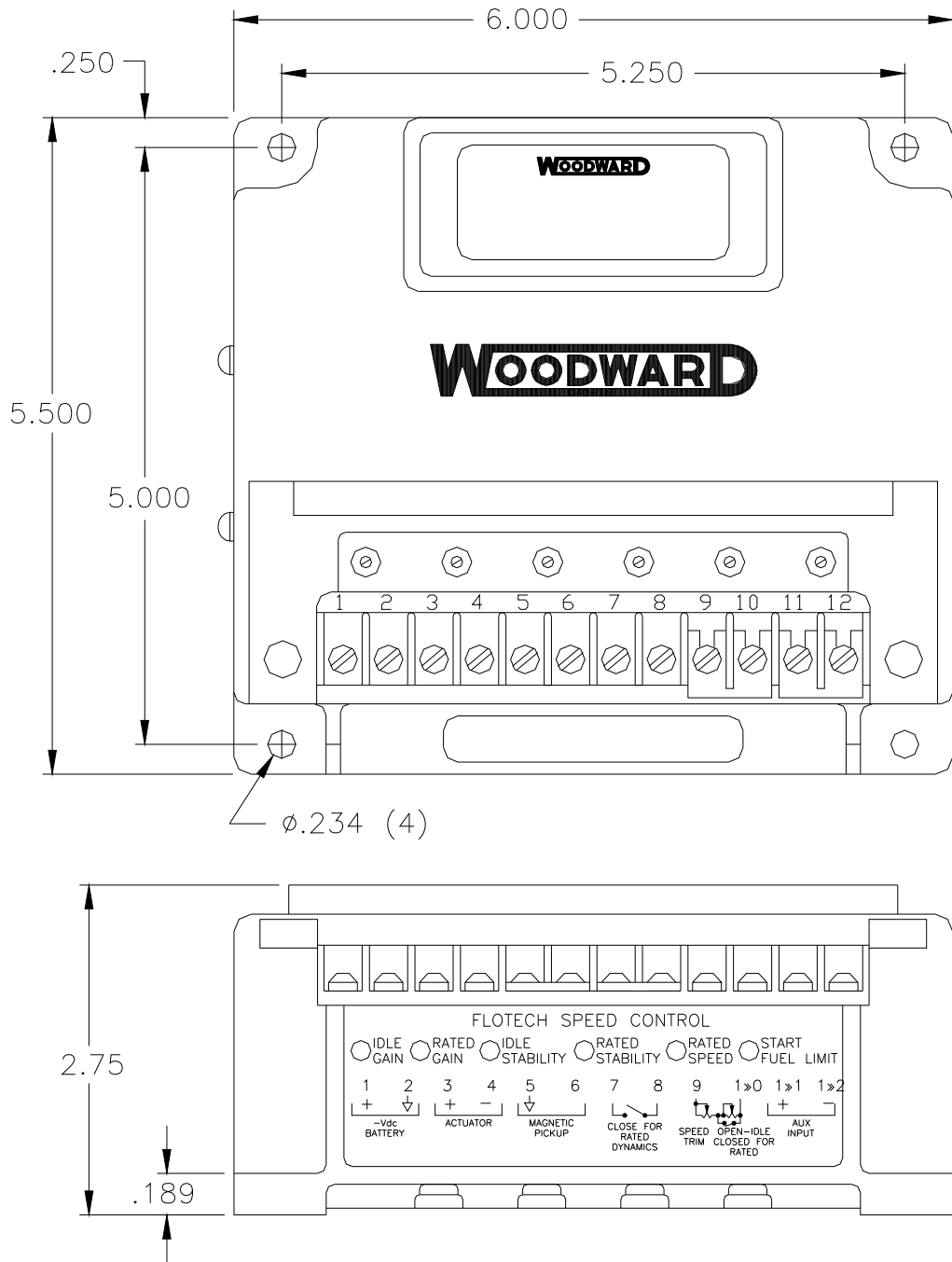
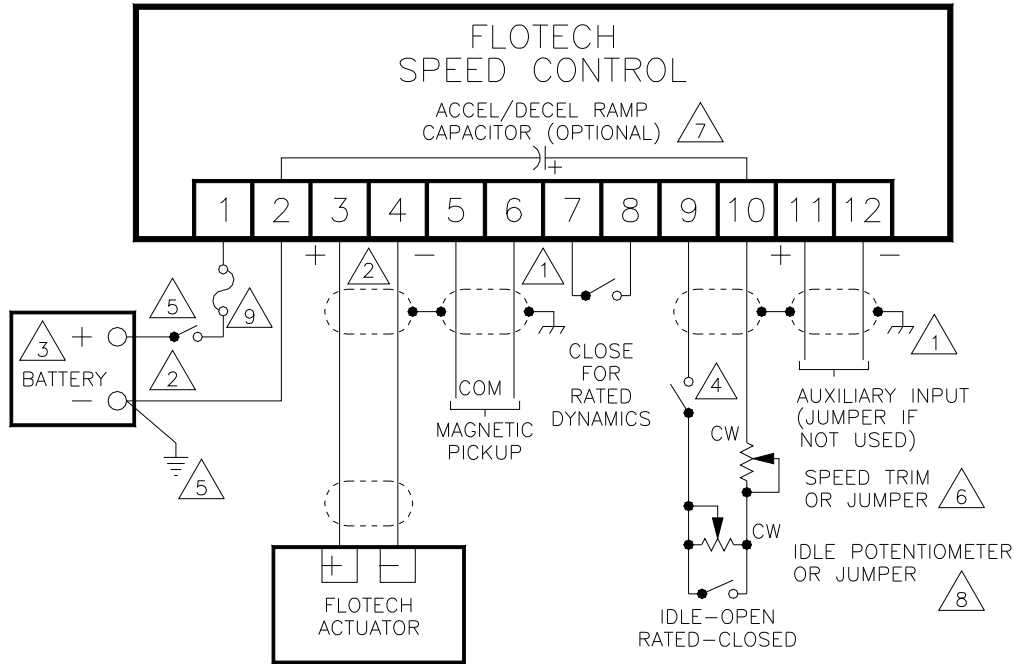

Figure 1-1. Flo-Tech Speed Control and Throttle Applied to a Gas Engine



041-207
97-02-14

Figure 1-2. Flo-Tech Control Outline Drawing



- 1 Shielded wires to be twisted pairs with shield grounded at one end only.
- 2 No. 18 AWG or 20 AWG stranded wire. Must be as short as possible. 50 ft. maximum wire length for 20 AWG wire. 80 ft. maximum wire length for 18 AWG wire.
- 3 Use P/N 8290-196 for 12 volt system.
Use P/N 8290-195 for 24 volt system.
- 4 Open for minimum fuel.
- 5 For positive ground systems, switch and fuse to be located in series with battery (-) and terminal 2. Positive terminal becomes chassis ground. Leads from battery to terminals 1 & 2 must be direct and not pass through distribution points.
- 6 Approximate speed change with trim potentiometer
±2.5% using a 1K Ohm potentiometer
±5% using a 2K ohm potentiometer
- 7 About one second ramp time per 50 μ F. Capacitor specifications: 200 μ F maximum, 15 WVdc. minimum. 15 WVdc maximum. Less than 30 μ A DC leakage current over temperature range.
- 8 Idle range about 25% to 100% rated using 50K potentiometer.
- 9 Use a 1 amp fuse (3 AG or GLM type).

041-209
97-11-10 skw

Figure 1-3. Plant Wiring Diagram

Chapter 2. Installation

Introduction

This chapter contains general installation instructions for the Flo-Tech™ Speed Control. Power requirements, ambient temperature limits, and location considerations are included to determine the best location for the control.

Speed Control Installation

Unpacking

Be careful when unpacking the electronic control. Check the control for signs of damage such as bent or dented panels, scratches, and loose or broken parts. Notify the shipper and Woodward if damage is found.

Mounting

The control box is designed to operate within a temperature range of -40 to $+70$ °C (-40 to $+158$ °F).

Mount the control in a location with space for adjustment and wiring access. Do not expose the control to sources of radiant heat such as exhaust manifolds or turbochargers. Choose a protected location so the control won't be damaged when moving the engine or when nearby equipment is moving. Mount the control close enough to the fuel valve and battery to meet the wire-length requirements (see wiring instructions in this chapter). Fuse the power source with a 1 amp fuse, as shown in the plant wiring diagram (Figure 1-3).

Do not install the control box directly on the engine.

The control will generate some heat, and surfaces must be open to normal air movement. No special ventilation is required.

Ideally, the control should be mounted flush to the metal side of a control cabinet, protected from the weather and high humidity, and close to the engine being controlled. The location should provide protection from high-voltage or high-current devices, or devices which produce electro-magnetic interference. After initial adjustments are completed, all functions may be selected with remote switches on the control panel. Ready access to the control will not be required for normal engine operation.

Magnetic Pickup

Install the magnetic pickup (MPU) to work with the selected gear through a housing or rigid bracket. Make sure the sensed gear is of magnetic material. Set the gap between the gear and the end of the magnetic pickup according to instructions which accompany the pickup.

Magnetic pickups of various sizes are available from Woodward.

The standard models of magnetic pickups require mating connectors, MS 3102R-18-3P. The connectors can be furnished with the MPU ordered from Woodward.

Manual 82510 *Magnetic Pickups and Proximity Switches for Electric Governors* contains detailed information on the installation of the sensing device.

Wiring Instructions

External wiring connections and shielding requirements for a typical control installation are shown in the plant wiring diagram (Figure 1-3). These wiring connections and shielding requirements are explained in the balance of this chapter.

Electromagnetic interference (EMI) is the undesirable interaction of electronic circuits with each other and sometimes with themselves.

Woodward has established procedures to prevent most EMI which will affect prime-mover-control circuits. Following these procedures is a slight extra expense in planning and installing electronic governing systems, but is inexpensive insurance over the life of the plant. Follow all of the shielding instructions to assure maximum efficiency and dependability of the electronic governing system.

Application Note 50532 *EMI Control for Electronic Governing Systems* has additional information on EMI causes and prevention.

To satisfy EMC requirements, a varistor must be attached to the input power connection pins (1 & 2). The varistor should be equivalent to a V47ZA7.

Shielded Wiring

All shielded cable must be twisted conductor pairs. Do not attempt to tin the braided shield. All signal lines should be shielded to prevent picking up stray signals from adjacent equipment. Connect the shields to the control case as shown in the plant wiring diagram (Figure 1-3). Wire exposed beyond the shield should be as short as possible, not exceeding 150 mm (6 inches). The other end of the shields must be left open and insulated from any other conductor. Do not run shielded signal wires in conduit or bundled with high voltage or high current wires.

Magnetic Pickup Connections

Use 1.0 mm² or 0.5 mm² (18 or 20 AWG) shielded two-conductor cable from the magnetic pickup to terminals 5 and 6 on the control. Leave the shield open at the magnetic pickup and ground the shield at the control. Polarity is unimportant.

Speed Trim Connections

If a speed-trim pot is to be used, it should be connected to terminals 9 and 10, as shown on the plant-wiring diagram (Figure 1-3). Use 1.0 mm² or 0.5 mm² (18 or 20 AWG) shielded cable with the shield open at the potentiometer and switch connections and tied to chassis ground at the control end.

A 1 k Ω pot will provide about ± 2.5 percent speed change from maximum to minimum setting. A 2 k Ω pot will offer about ± 5 percent change in speed. Install a single-pole, single-throw switch between terminal 9 and the pot to provide minimum fuel or shutdown when open.

**WARNING**

Do not use the "Open for Min Fuel" switch in the speed trim circuit for emergency shutdown of the engine. The emergency shutdown must be completely separate from the speed control circuit, not depending on the fuel valve or control to provide the shutdown. Life threatening overspeed is possible if a separate overspeed system is not used.

A speed-trim pot is often required for loading when the a load sensor is used in the droop mode, or for remote adjustment.

Idle/Rated Switch

Use 1.0 mm² or 0.5 mm² (18 or 20 AWG) shielded two-conductor cable to install a single-pole, single-throw switch between terminals 12 and 13 on the control. Leave the shield open at the switch and ground the shield with the other shields on the case.

When the switch is open, the engine will operate at the idle speed. When the switch is closed the engine will operate at the rated speed.

The installation should take into account that the engine will go directly to high speed should the engine restart before the switch is opened. If idle-rated speed selection is not desired, install a jumper (Woodward part number 1606-899) across terminals 9 and 10.

Idle/Rated Dynamics Switch

Connect a single-pole, single-throw switch between terminals 7 and 8. Close the switch for rated dynamics, open for idle dynamics. If desired, a single-throw double-pole switch can be installed on terminals 7–8 and 9–10 to automatically select rated dynamics when rated speed is selected. The switch between terminals 7 and 8 may be connected to a switch that will be closed by the auxiliary breaker switch, if it is desired to go automatically to rated dynamics when the generator unit is paralleled with the bus (loaded). This permits using the idle (slower) dynamics while synchronizing and then changing to the rated (quicker) dynamics when load is applied. Use 18 or 20 AWG stranded wire to connect the switch to the terminals. The wire does not have to be shielded.

Auxiliary Input

If a synchronizer, load sensor, or other speed modifying equipment is used, attach it to terminals 11 (+3 Vdc) and 12 (–3 Vdc). Use 1.0 mm² or 0.5 mm² (18 or 20 AWG) shielded, twisted-pair wire to make the connection. Tie the shield to the speed-control chassis. Jumper terminal 11 to 12 if special speed-modifying equipment is not used.

Accel/Decel Ramp

If a ramp generator or a capacitor is used to control acceleration and deceleration rates, connect positive (+) to terminal 10 and negative (-) to terminal 2. Using a capacitor between terminals 10 and 2 will provide about one second of ramp time per 50 μF . The ramp is non-linear. Use a 50 to 200 μF capacitor, 15 Vdc minimum working voltage. The capacitor must have less than 30 μA dc leakage current over the temperature range. If a Woodward Ramp Generator (8271-909) is attached to terminals 10 and 2, the ramp can be adjusted up to 25 seconds from idle to rated speed.

Shields

Ground all shields to one of the bolts used to mount the control. Do not have any of the shields tied to ground at the other end. This is necessary to reduce EMI signals from entering the control with ground loops.

When passing shields through connectors and terminal blocks, treat each shield as if it were a signal wire. Each shield must be given its own pin or terminal and be kept insulated from nearby wires and metal conductors. Do not tin (solder) braided shields.

Connect the speed-control chassis to system ground.

Chapter 3.

Calibration and Operation

Introduction

Initial calibration and troubleshooting of the Flo-Tech Speed Control are identical. Many of the settings are interrelated. For this reason, if trouble is experienced, the best procedure is to follow the initial installation routine completely to see if the problem is cured by adjustment of the system.

Signal Generator

A signal generator to simulate the output of the MPU will make setup or troubleshooting of the electronic control system easier and safer, since it will allow the technician to set idle and rated speeds and check all wiring without running the engine. The wave form can be sine, square, or triangular. The signal generator must be capable of generating the frequency of the control system, not the rpm of the engine. The frequency will be the number of teeth on the sensed gear which will be exposed to the MPU during one revolution of the engine times the desired rpm divided by 60 (revolutions per second).

$$Hz = \frac{\text{No. of teeth} \times \text{RPM}}{60}$$

If a signal generator is not available, all checks can be made with the engine, but overspeeds are possible.



WARNING

Be prepared to make an emergency shutdown when starting the engine, turbine, or other type of prime mover, to protect against runaway or overspeed with possible personal injury, loss of life, or property damage.

Installation Checks

Do the checks in the order indicated. Terminal numbers in this chapter refer to the speed control.

1. Check that all electrical connections are correctly made and terminal screws tightened, the magnetic pickup is properly installed and the jam nut tightened, and the fuel valve and drain line are securely fastened and correctly installed.
2. Do not start the engine now. Turn on governor power. Check the battery voltage at terminals 1 (+) and 2 (-). It must be from 18 to 32 Vdc (10 to 14 Vdc for the 12-volt control).
3. **If a signal generator is available:** Attach the output to terminals 5 and 6, leaving the MPU connections off. Set the signal-generator output between 2 and 10 Vrms. If a signal generator is not available, proceed to step 8.

4. Set the signal-generator frequency to about half of idle speed. Close the Idle/Rated switch. Turn the signal generator and governor power on. The voltage across terminals 3 and 4 should measure about 5 Vdc (Start Fuel Limit must be fully clockwise).
5. Set the signal generator for MPU frequency at rated speed. Close the Idle/Rated switch. Set the external speed trim pot (if used) at mid position. Observe the output from terminals 3 and 4.
 - a. If the output is at max-fuel position (about 5 Vdc), slowly turn the rated-speed potentiometer counterclockwise until the signal just begins to move to minimum.
 - b. If the output is at minimum, slowly turn the rated-speed potentiometer clockwise until the signal just begins to move to maximum.

Continue to adjust the rated-speed pot very slowly, trying to stop the signal between minimum and maximum. Stop adjusting when the signal moves slowly. It will not be possible to stop the motion. The rated-speed reference is now set very close to desired speed.
6. Open the Idle/Rated switch. Set the signal generator for MPU frequency at idle speed. (Preset the idle speed only after presetting rated speed.)
 - a. If the signal is at maximum-fuel position, slowly turn the idle-speed potentiometer counterclockwise until the signal begins to move to minimum.
 - b. If the signal is at minimum, slowly turn the idle-speed potentiometer clockwise until the signal just begins to move to maximum.
7. Continue to adjust the idle-speed pot very slowly, trying to stop the signal between minimum and maximum. Stop adjusting when the signal moves slowly. It will not be possible to stop the signal. The idle-speed reference is now set very close to desired idle speed.
8. **If a signal generator is not available**, turn the rated speed pot fully counterclockwise. Turn the idle-speed pot fully clockwise. Remove the MPU wires from the speed control and measure between 85 and 300 Ω resistance across the MPU wires. If the resistance is correct replace the connection.

Initial Pre-Start Settings

1. Rated Speed: If RATED SPEED was not set with a signal generator, set the RATED SPEED potentiometer to minimum (fully counterclockwise). Set the external speed trim, if used, to mid-position.
2. Stability: Set the RATED and IDLE STABILITY potentiometers to mid position.
3. Gain: Set the RATED and IDLE GAIN potentiometers to mid position.
4. Idle Speed: If IDLE SPEED was not set with a signal generator, set the IDLE SPEED potentiometer at maximum (fully clockwise).
5. Start Fuel Limit: Set the START FUEL LIMIT pot at mid point (maximum is fully clockwise).

6. Close the circuit between terminals 9 and 10 (Close for Rated).

Start-up Adjustments

1. Prepare to start the engine. Read this entire chapter before attempting to start the engine. Interrelated problems can occur, and an understanding of all possibilities is needed before using a control for the first time.

In case the newly installed Flo-Tech Speed Control does not control engine speed, be prepared to: 1) remove the power from the control with the switch between the battery and terminal 1; and 2) initiate emergency shutdown procedures including manually shutting off the fuel supply.



Be prepared to make an emergency shutdown when starting the engine, turbine, or other type of prime mover, to protect against runaway or overspeed with possible personal injury, loss of life, or property damage.

Adjust for Stable Operation

Read the following paragraphs before attempting initial engine start up. Dynamics must be quickly adjusted after initial start up.

Immediately after the initial start up, it will be necessary to adjust the governor for stable operation. Idle and Rated dynamics are completely separate. The adjustments must be made according to the dynamics selected. In most cases the idle speed has been preset at maximum (fully clockwise) and Rated Speed is selected. In many cases the selection of rated speed will not indicate a desire for rated dynamics, which will be used when the engine is loaded. Idle dynamics may be selected and adjusted while rated speed is selected.

If the engine is hunting at a rapid rate, slowly decrease the GAIN (turn the potentiometer counterclockwise) until performance is stable.

If the engine is hunting at a slow rate, increase the STABILITY (turn the potentiometer clockwise) until the engine stabilizes. If increasing the STABILITY potentiometer does not stabilize the engine, it also may be necessary to slowly decrease the GAIN (turn the potentiometer counterclockwise).

1. Start cranking the engine. If the signal from terminals 3 and 4 does not show a positive voltage (2 to 6 Vdc) check the MPU.

Minimum voltage required from the MPU to operate the electronic control is 1.0 Vrms, measured at cranking speed or the lowest controlling speed. Measure the voltage while cranking with the speed sensor connected to the control. Be sure to prevent the engine from starting. At 5 percent of the lower value of the control's speed range, the failed speed-sensing circuit is cleared. For example 150 Hz is required on the 3000 to 6000 Hz speed range.

If necessary, increase the Start Fuel Limit (turn clockwise) while cranking until the engine starts. The Start Fuel Limit must be high enough to allow the engine to reach the selected idle or rated speed.

2. If the control increases the engine speed above its cranking speed, the engine should continue to operate at the rated speed. (If the rated speed is too low, it may be necessary to increase the Rated Speed setting slightly by turning the rated-speed pot a little clockwise.) If the engine stops, it indicates a MPU problem. The MPU must produce a minimum of 1 Vac rms to activate the control. Failure to produce the minimum signal can be caused by improper MPU installation, selection of an incorrect gear, improper wiring between the MPU and the control, or a defective MPU.
3. It will be necessary to immediately adjust the control for stable operation after the engine starts. (See Adjust for Stable Operation and Dynamic Adjustment.)
4. With the engine running and stable, slowly increase the rated-speed setting with the RATED SPEED pot until the desired rated speed is reached.

Dynamic Adjustment

The object of the GAIN and STABILITY potentiometer adjustments is to obtain the optimum, or desired, stable engine-speed response (see Figure 3-1).

Increasing the setting of the GAIN potentiometer provides faster transient response (decreases the amount of speed change from a sudden change in load). To achieve the best response, slowly increase the GAIN (turn the potentiometer clockwise) until the engine becomes slightly unstable, then slowly turn the GAIN back counterclockwise as necessary to stabilize engine speed.

Step load the engine to make sure the engine returns to the proper speed with little overshoot or undershoot of the speed setting. (To reduce overshoot, increase the STABILITY setting by turning the potentiometer clockwise).

Increasing the STABILITY clockwise will require decreasing the GAIN (turning the GAIN potentiometer counterclockwise) to maintain stable operation.

If the engine is slow in returning to the proper speed, decrease the STABILITY by turning the potentiometer counterclockwise.

Figure 3-1 illustrates engine starts with no ramp or capacitor connected to the control, step loadings at four different STABILITY potentiometer settings, and stable, steady-state running conditions. These are typical performance curves on a naturally-aspirated (not turbocharged) diesel engine.

Optimum performance is not necessarily obtained with the GAIN potentiometer at the maximum stable clockwise position. In some cases, the gain must be reduced slightly to ensure stability under widely varying conditions.

5. **LOW IDLE SPEED ADJUSTMENT:** The engine should be at rated speed with the IDLE SPEED potentiometer set at maximum (fully clockwise). Open the external CLOSE FOR RATED contact.
6. Decrease the IDLE SPEED (turn the potentiometer counterclockwise) until the desired idle speed is reached. It may be necessary to adjust the idle dynamics to maintain stability as speed is lowered.

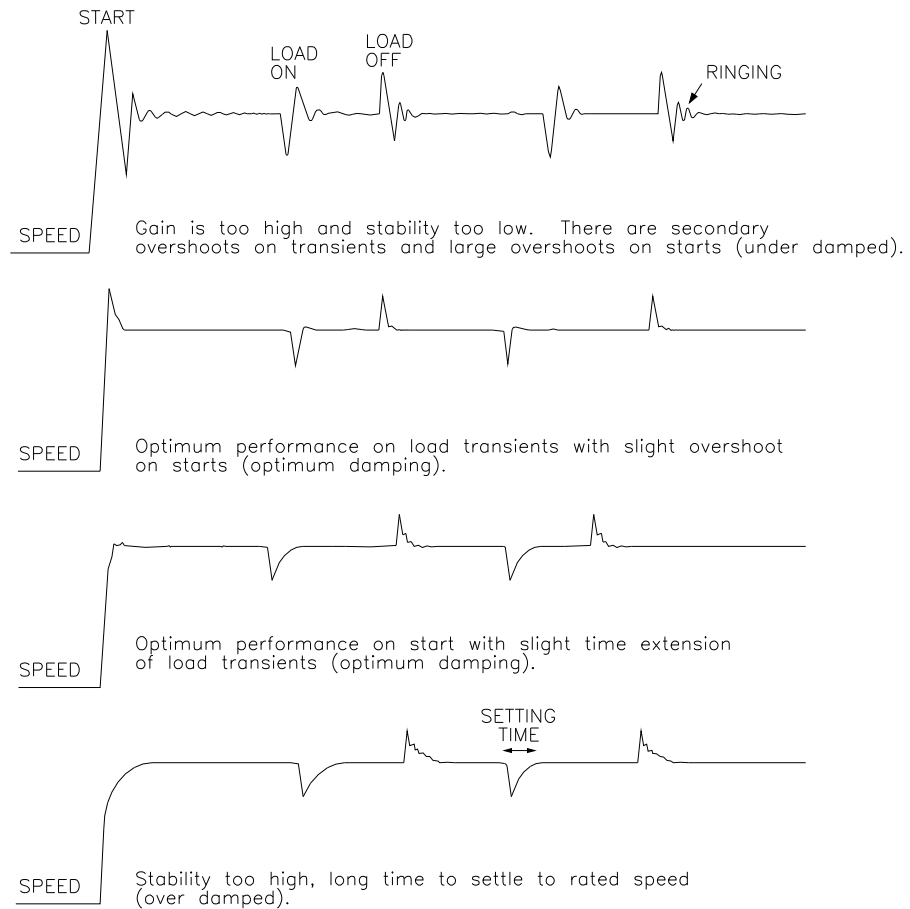

041-210
97-02-14

Figure 3-1. Diesel Engine Response Curves

7. If idle dynamics were selected on initial start-up, it will now be necessary to set rated dynamics. Load the engine, then select rated dynamics. Adjust for stable but active response as was done with the idle dynamics. The idle dynamics will provide stable operation of a loaded engine, but will not provide optimum response to load changes. If the rated dynamics are set for optimum engine performance when the engine is loaded, the engine should not be stable when unloaded unless the idle dynamics are selected. Rated dynamics are normally set with the engine at operating speed.

Engine response will change as the engine warms up. It may be necessary to tune dynamics after warm-up. It may be necessary to compromise optimum control dynamics with a cold engine in order to have optimum dynamics when the engine is at operating temperature.

Start Fuel Limit

1. The START FUEL LIMIT was set at a point that allowed the cold engine to start during initial start up procedures. If START FUEL LIMIT is to be used, it should now be adjusted after engine stability and response rates are correctly adjusted.
2. Adjusting the START FUEL LIMIT counterclockwise will prevent the fuel valve from delivering a maximum amount of fuel to the injectors until the selected speed (Idle or Rated) is reached. Adjust for desired engine performance during start up. The Start Fuel Limit must be set high enough to allow the engine to reach the selected speed.
3. The Start Fuel Limit should be adjusted from counterclockwise to obtain the desired characteristics while starting the engine. NOTE: There may be differences in startup characteristics of cold and hot engines.

Chapter 4.

Description of Operation

Introduction

The Woodward Flo-Tech™ Speed Control provides precise speed control of an engine with separate dynamics for stable, responsive engine operation at rated and idle speeds.

Electronic Circuits

All circuits in the Flo-Tech Speed Control are solid state and are not serviceable in the field. The printed circuit board is manufactured by Woodward to provide maximum tolerance to temperature and vibration. Components are wave soldered to the board, and the circuits are computer-tested to assure maximum dependability and accuracy.

Potentiometers, accessible through the control-box case or input through the terminal board, provide all adjustments to the control system. A 10-turn potentiometer provides precise adjustment of the rated-speed setting. One-turn potentiometers provide adjustment for rated speed, fuel limit, idle or unloaded gain and stability, and rated or loaded gain and stability. In addition, the control can be fitted with external potentiometers to set the idle speed and to trim the rated speed from a remote location.

Speed Control

The control converts the signal from the magnetic pickup on the engine into a dc voltage level which is proportional to engine speed. This voltage level is compared to the rated or idle speed setting. After the speed error is modified by GAIN, STABILITY, and SPEED TRIM, the result is sent to a driver that provides 0–200 mA to the Flo-Tech Throttle installed on the engine.

Stability and Gain

The stability and gain adjustments on the Flo-Tech Speed Control allow tailoring of the response rates at idle and at rated speeds to match the engine being controlled.

STABILITY adjustments affect engine reaction time when recovering after a sudden load change. The magnitude of the speed change resulting from a sudden change in load is controlled by the GAIN adjustments.

Start Fuel Limit

A one-turn pot is available to set a start-fuel limit. The Start Fuel Limit provides a maximum fuel flow until the engine is at idle or rated speed, as selected. When the fuel-limit potentiometer is set fully counterclockwise, the valve will go to a low-fuel position until selected speed is reached. Fuel limiting can prevent smoke during startup, can aid starting on some types of engines, or can be used to prevent excessive overspeed as an engine reaches rated or idle speed. Fuel limit is automatically enabled when the MPU signal falls to zero, and disabled just before the engine reaches idle or rated speed.

Failed Speed Sensor

A safety circuit is included in the Flo-Tech Speed Control to cause the throttle to go to minimum position if the signal from the magnetic pickup is lost. This is protection against loss of control should either the magnetic pickup instrument or the wiring from the magnetic pickup to the control fail. Without this safety circuit, the valve would go to maximum or to the fuel limit should the control lose the magnetic pickup signal.

Auxiliary Input

The auxiliary input is provided to allow the Flo-Tech Speed Control to be used with a load sensor or other auxiliary device such as a process control or SPM-A. A Load Sensor is used with the control for isochronous or electrical droop paralleling. With an isolated bus, isochronous load sharing is usually selected. In isochronous operation, the Load Sensor produces a load signal which is shared with the other Load Sensors on line through the parallel lines. The parallel-line voltage represents the average load of the units on line. By comparing the paralleling-line voltage to its own load, the load sensor calculates an output applied to the auxiliary input of the Flo-Tech control. This output raises or lowers, as necessary, the generator output to make the load of its unit equal to the average load. The load-sensor output directly biases the speed-loop circuit of the speed control to affect the fuel-level setting and precisely maintain its proportional share of system load while maintaining a fixed frequency.

Ramp Generator

A Ramp Generator may be attached to terminals 10 (+) and 2 (-) to slow the speed change between idle and rated speeds. Once set, it provides a constant speed change per second by biasing the speed reference when changing from idle to rated and vice versa. Accel and Decel pots on the ramp generator control the rate of change.

A capacitor can be connected between terminals 10 and 2 to provide a non-linear ramp between idle and rated and between rated and idle. This method provides the same rate for both acceleration and deceleration, about one second of ramp time per 50 μF of capacitance (200 μF maximum). The capacitor must be 15 Vdc minimum working voltage with less than 30 μA dc leakage over the operating temperature range.

Speed Trim

A potentiometer can be installed to terminals 9 (counterclockwise) and 10 (clockwise and wiper) to provide remote trim of rated speed. A 1 $\text{k}\Omega$ potentiometer will provide ± 2.5 percent change of rated speed. A 2 $\text{k}\Omega$ potentiometer will provide ± 5 percent change in rated speed. The control is not subject to temperature drift, and the potentiometer for remote speed trim is not usually needed in a single-engine application.

Chapter 5.

Troubleshooting

Introduction

Improper engine operation is often the result of factors other than governor operation. The following paragraphs are provided to give tips about engine problems which can resemble governor problems. Make sure the engine is operating correctly before making any changes in the governor.

Attempting to correct engine or load problems with untimely governor adjustment can add to the problems involved with solving improper operation.

Most governor problems are corrected by carefully repeating the calibration procedure given in the preceding chapter. There are no adjustments available within the valve.

If possible, isolate the governor from the engine to determine if the problem is with the governor and not with the engine or the load on the engine.

Governor system faults are usually caused by problems in the installation. Carefully review all the wiring connections, the power supply, and the Flo-Tech Throttle before making any adjustments to the control box. The throttle valve should be considered as a possible control problem if it was not removed during installation.

Fuel supply, pressure regulators, carburetors, and ignition conditions can present problems which resemble governor problems.

When the Governor is at Fault

Before making any adjustments to the Flo-Tech control review Chapters 3 and 4 to better understand the interrelated workings of the various adjustments and features.

If the engine will not start, the following problems may exist:

The circuit between terminals 9 and 10 is not closed. The governor is in a shutdown mode if this circuit is open. Jumper the two terminals to make sure the idle speed pot, the speed trim pot (if used), or the shutdown switch is not faulty. Inspect the existing jumper if a shutdown switch, idle speed pot, and speed trim pot are not used.

The start fuel limit is preventing adequate air flow.

The 12 or 24 volt supply is not present at terminals 1 and 2.

Stability Problems

Stability problems not caused by the engine or gas pressure at the carburetor require careful following of the setup procedure provided in Chapter 3. Follow every step when readjusting the control.

If the engine oscillates when cold and stabilizes when warm, make sure that the desired (usually idle) dynamics have been selected. Turn the selected dynamics gain pot slightly counterclockwise. Turn the stability pot slightly clockwise if required to maintain stability.

Magnetic Pickup

The MPU must provide a minimum pulse signal of 1 volt to the control . It is highly unusual for an MPU to fail if it is properly installed. The most common failure is due to the pickup being screwed in too far and hitting the gear it is sensing. If the MPU does not produce the required signal, check the installation to make sure it is properly located on the sensed wheel. If the MPU is not close enough to the sensed gear it will not produce an adequate signal.

Several different sizes of MPUs are available to fit different size gears.

Check that the gear is of magnetic material, necessary to drive the MPU. Check the wiring from the MPU to the control.

Refer to Manual 82510 *Magnetic Pickups and Proximity Switches for Electric Governors* for more information about required gear shapes, sizes, and surface speeds.

Note that the MPU generates a voltage signal when a tooth of the sensed gear breaks the magnetic field emitted from the tip of the pickup. The pickup does not require an excitation voltage from the control.

Chapter 6.

Product Support and Service Options

Product Support Options

If you are experiencing problems with the installation, or unsatisfactory performance of a Woodward product, the following options are available:

1. Consult the troubleshooting guide in the manual.
2. Contact the **OE Manufacturer or Packager** of your system.
3. Contact the **Woodward Business Partner** serving your area.
4. Contact Woodward technical assistance via email (EngineHelpDesk@Woodward.com) with detailed information on the product, application, and symptoms. Your email will be forwarded to an appropriate expert on the product and application to respond by telephone or return email.
5. If the issue cannot be resolved, you can select a further course of action to pursue based on the available services listed in this chapter.

OEM or Packager Support: Many Woodward controls and control devices are installed into the equipment system and programmed by an Original Equipment Manufacturer (OEM) or Equipment Packager at their factory. In some cases, the programming is password-protected by the OEM or packager, and they are the best source for product service and support. Warranty service for Woodward products shipped with an equipment system should also be handled through the OEM or Packager. Please review your equipment system documentation for details.

Woodward Business Partner Support: Woodward works with and supports a global network of independent business partners whose mission is to serve the users of Woodward controls, as described here:

- A **Full-Service Distributor** has the primary responsibility for sales, service, system integration solutions, technical desk support, and aftermarket marketing of standard Woodward products within a specific geographic area and market segment.
- An **Authorized Independent Service Facility (AISF)** provides authorized service that includes repairs, repair parts, and warranty service on Woodward's behalf. Service (not new unit sales) is an AISF's primary mission.
- A **Recognized Engine Retrofitter (RER)** is an independent company that does retrofits and upgrades on reciprocating gas engines and dual-fuel conversions, and can provide the full line of Woodward systems and components for the retrofits and overhauls, emission compliance upgrades, long term service contracts, emergency repairs, etc.

A current list of Woodward Business Partners is available at www.woodward.com/directory.

Product Service Options

Depending on the type of product, the following options for servicing Woodward products may be available through your local Full-Service Distributor or the OEM or Packager of the equipment system.

- Replacement/Exchange (24-hour service)
- Flat Rate Repair
- Flat Rate Remanufacture

Replacement/Exchange: Replacement/Exchange is a premium program designed for the user who is in need of immediate service. It allows you to request and receive a like-new replacement unit in minimum time (usually within 24 hours of the request), providing a suitable unit is available at the time of the request, thereby minimizing costly downtime.

This option allows you to call your Full-Service Distributor in the event of an unexpected outage, or in advance of a scheduled outage, to request a replacement control unit. If the unit is available at the time of the call, it can usually be shipped out within 24 hours. You replace your field control unit with the like-new replacement and return the field unit to the Full-Service Distributor.

Flat Rate Repair: Flat Rate Repair is available for many of the standard mechanical products and some of the electronic products in the field. This program offers you repair service for your products with the advantage of knowing in advance what the cost will be.

Flat Rate Remanufacture: Flat Rate Remanufacture is very similar to the Flat Rate Repair option, with the exception that the unit will be returned to you in “like-new” condition. This option is applicable to mechanical products only.

Returning Equipment for Repair

If a control (or any part of an electronic control) is to be returned for repair, please contact your Full-Service Distributor in advance to obtain Return Authorization and shipping instructions.

When shipping the item(s), attach a tag with the following information:

- return number;
- name and location where the control is installed;
- name and phone number of contact person;
- complete Woodward part number(s) and serial number(s);
- description of the problem;
- instructions describing the desired type of repair.

Packing a Control

Use the following materials when returning a complete control:

- protective caps on any connectors;
- antistatic protective bags on all electronic modules;
- packing materials that will not damage the surface of the unit;
- at least 100 mm (4 inches) of tightly packed, industry-approved packing material;
- a packing carton with double walls;
- a strong tape around the outside of the carton for increased strength.

NOTICE

To prevent damage to electronic components caused by improper handling, read and observe the precautions in Woodward manual 82715, *Guide for Handling and Protection of Electronic Controls, Printed Circuit Boards, and Modules*.

Replacement Parts

When ordering replacement parts for controls, include the following information:

- the part number(s) (XXXX-XXXX) that is on the enclosure nameplate;
- the unit serial number, which is also on the nameplate.

Engineering Services

Woodward's Full-Service Distributors offer various Engineering Services for our products. For these services, you can contact the Distributor by telephone or by email.

- Technical Support
- Product Training
- Field Service

Technical Support is available from your equipment system supplier, your local Full-Service Distributor, or from many of Woodward's worldwide locations, depending upon the product and application. This service can assist you with technical questions or problem solving during the normal business hours of the Woodward location you contact.

Product Training is available as standard classes at many Distributor locations. Customized classes are also available, which can be tailored to your needs and held at one of our Distributor locations or at your site. This training, conducted by experienced personnel, will assure that you will be able to maintain system reliability and availability.

Field Service engineering on-site support is available, depending on the product and location, from one of our Full-Service Distributors. The field engineers are experienced both on Woodward products as well as on much of the non-Woodward equipment with which our products interface.

For information on these services, please contact one of the Full-Service Distributors listed at www.woodward.com/directory.

Contacting Woodward's Support Organization

For the name of your nearest Woodward Full-Service Distributor or service facility, please consult our worldwide directory published at www.woodward.com/directory.

You can also contact the Woodward Customer Service Department at one of the following Woodward facilities to obtain the address and phone number of the nearest facility at which you can obtain information and service.

Products Used In Electrical Power Systems	Products Used In Engine Systems	Products Used In Industrial Turbomachinery Systems
<u>Facility</u> ----- <u>Phone Number</u>	<u>Facility</u> ----- <u>Phone Number</u>	<u>Facility</u> ----- <u>Phone Number</u>
Brazil -----+55 (19) 3708 4800	Brazil -----+55 (19) 3708 4800	Brazil -----+55 (19) 3708 4800
China -----+86 (512) 6762 6727	China -----+86 (512) 6762 6727	China -----+86 (512) 6762 6727
Germany:	Germany-----+49 (711) 78954-510	India -----+91 (129) 4097100
Kempen----+49 (0) 21 52 14 51	India -----+91 (129) 4097100	Japan-----+81 (43) 213-2191
Stuttgart--+49 (711) 78954-510	Japan-----+81 (43) 213-2191	Korea-----+82 (51) 636-7080
India -----+91 (129) 4097100	Korea-----+82 (51) 636-7080	The Netherlands- +31 (23) 5661111
Japan-----+81 (43) 213-2191	The Netherlands- +31 (23) 5661111	Poland-----+48 12 295 13 00
Korea-----+82 (51) 636-7080	United States----+1 (970) 482-5811	United States----+1 (970) 482-5811
Poland-----+48 12 295 13 00		
United States----+1 (970) 482-5811		

For the most current product support and contact information, please visit our website directory at www.woodward.com/directory.

Technical Assistance

If you need to contact technical assistance, you will need to provide the following information. Please write it down here before contacting the Engine OEM, the Packager, a Woodward Business Partner, or the Woodward factory:

General

Your Name _____

Site Location _____

Phone Number _____

Fax Number _____

Prime Mover Information

Manufacturer _____

Engine Model Number _____

Number of Cylinders _____

Type of Fuel (gas, gaseous, diesel,
dual-fuel, etc.) _____

Power Output Rating _____

Application (power generation, marine,
etc.) _____

Control/Governor Information

Control/Governor #1

Woodward Part Number & Rev. Letter _____

Control Description or Governor Type _____

Serial Number _____

Control/Governor #2

Woodward Part Number & Rev. Letter _____

Control Description or Governor Type _____

Serial Number _____

Control/Governor #3

Woodward Part Number & Rev. Letter _____

Control Description or Governor Type _____

Serial Number _____

Symptoms

Description _____

If you have an electronic or programmable control, please have the adjustment setting positions or the menu settings written down and with you at the time of the call.

Revision History

Changes in Revision D—

- Added auxiliary input voltage (page 9)

Declarations



00149-04-EUR-02-01

DECLARATION OF CONFORMITY

According to EN 45014

Manufacturer's Name: WOODWARD GOVERNOR COMPANY (WGC)
Industrial Controls Group

Manufacturer's Address: 1000 E. Drake Rd.
Fort Collins, CO, USA, 80525

Model Name(s)/Number(s): EPG 12V 8290-187 and similiar
EPG 24V 8290-185 and similiar

Conformance to Directive(s): 89/336/EEC COUNCIL DIRECTIVE of 03 May 1989 on
the approximation of the laws of the Member States
relating to electromagnetic compatibility.

Applicable Standards: EN61000-6-2, 2001: EMC Part 6-2: Generic Standards -
Immunity for Industrial Environments
EN61000-6-4, 2001: EMC Part 6-4: Generic Standards -
Emissions for Industrial Environments

We, the undersigned, hereby declare that the equipment specified above conforms to the above Directive(s).

MANUFACTURER

Signature

Jennifer R. Williams

Full Name
Jennifer R. Williams

Position
Engineering Manager

Place
WIC, Fort Collins, CO, USA

Date
7-25-02.

We appreciate your comments about the content of our publications.

Send comments to: icinfo@woodward.com

Please reference publication **04173D**.



B04173:D



PO Box 1519, Fort Collins CO 80522-1519, USA
1000 East Drake Road, Fort Collins CO 80525, USA
Phone +1 (970) 482-5811 • Fax +1 (970) 498-3058

Email and Website—www.woodward.com

Woodward has company-owned plants, subsidiaries, and branches,
as well as authorized distributors and other authorized service and sales facilities throughout the world.

Complete address / phone / fax / email information for all locations is available on our website.