

MK-TD-120



FEATURE:

- Upper and lower inhibitors design, easy to installation
- Stainless steel construction
- Hermetically sealed IP68 protection class
- Truck scale, hopper scale, and tank weighing application

OUTLINE DIMENSIONS in millimeters

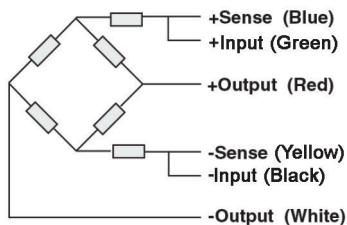
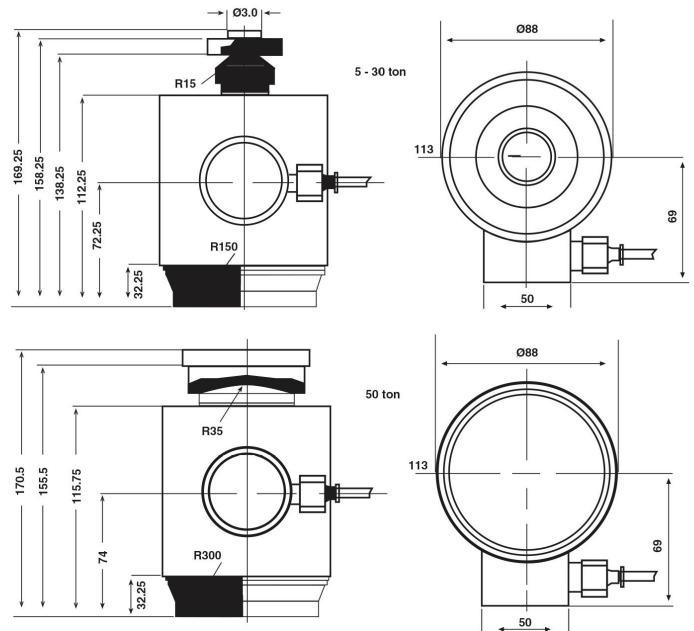

SPECIFICATION

Rated capacities	30, 50t	Temperature compensated	-10°C ~ +40°C
Rated output	1.5±0.002mV/V	Temperature, operating	-30°C ~ +70°C
Accuracy class	C3	Maximum safe overload	150%F.S
Creep error (30 min)	±0.02%F.S	Ultimate overload	250%F.S
Zero balance	±1%F.S	Excitation, recommended	10-12V DC
TC ZERO	±0.02%F.S/10°C	Excitation, maximum	15 V DC
TC SPAN	±0.02%F.S/10°C	Protection class	IP68
Input resistance	670±15Ω	Construction	Stainless steel
Output resistance	600±5Ω	Cable length	12m(30t), 14m(50t)
Insulation resistance	≥5000MΩ	Diameter	Φ 6mm