



CHL 50Hz/60Hz

Light Horizontal Multistage Centrifugal Pump

CHLK/CHLF(T)

supplierfilterair.com



Nanfang Pump Industry Co.,Ltd.

CNP Headquarter

Address: Renhe Town, Hangzhou China

PostCode: 311107

Tel: +86 571 86397810, 86397838

Fax: +86 571 86397809

E-mail: info@nanfang-pump.com

http://www.cnppump.com

E120305
subject to amendments



Company Profile



Founded in 1991, Nanfang Pump Industry Co., Ltd. (hereinafter referred to as CNP) has been listed on the Shenzhen Stock Exchange on 9th December 2010; Stock name: CNP; Stock code: 300145.

As the first enterprise specializing in the research and large-scale production of stainless steel stamping welded centrifugal pump in China, CNP is currently the professional manufacturer with the highest volume of production and marketing in that industry. It ranks first in the country in terms of product scope, sales volume, and production quality. The company has set up a complete network of marketing services to meet the requirements of overseas markets as well as domestic needs. The products have seen a wide range of application in the area of pressurization, industry, living water, cycling of air-conditioning water, heat supply, fire extinguishing system, pumping of underground water, treatment of sewage and waste water, chemical industry and desalination of sea water etc.

CNP has now entered into the fast track of development and has taken a major step forward in forging China Strong Pump Enterprise and World's famous brand in the Pump Industry. In order to better meet the client's needs and requirements for expansion, it has set up a wide network of selling and service, as well as offices and service centers in major cities in China, which are aimed at providing timely and effective services for our clients. Meanwhile, our company has successfully penetrated into the world market by forging a good business relationship with more than 50 countries and regions in the Europe, Northern American, and Southeast Asia etc.

Content

General Data

Performance scope	3
Application	4
Applicable medium	4
Pump	4
Curve conditions	4
Motor	4
Operation condition	4
Definition of Model	5
Material	5
Section drawing	6

Technical Data

CHL/CHLK2,50Hz	7
CHL/CHLK4,50Hz	9
CHL/CHLK8,50Hz	11
CHL/CHLK12,50Hz	13
CHL/CHLK16,50Hz	15
CHL/CHLK20,50Hz	17
CHLF/CHLF(T)2,50Hz	19
CHLF/CHLF(T)4,50Hz	21
CHLF/CHLF(T)8,50Hz	23
CHLF/CHLF(T)12,50Hz	25
CHLF/CHLF(T)16,50Hz	27
CHLF/CHLF(T)20,50Hz	29
CHL/CHLK2,60Hz	31
CHL/CHLK4,60Hz	33
CHL/CHLK8,60Hz	35
CHL/CHLK12,60Hz	37
CHL/CHLK16,60Hz	39
CHL/CHLK20,60Hz	41
CHLF/CHLF(T)2,60Hz	43
CHLF/CHLF(T)4,60Hz	45
CHLF/CHLF(T)8,60Hz	47
CHLF/CHLF(T)12,60Hz	49
CHLF/CHLF(T)16,60Hz	51
CHLF/CHLF(T)20,60Hz	53

● Performance scope

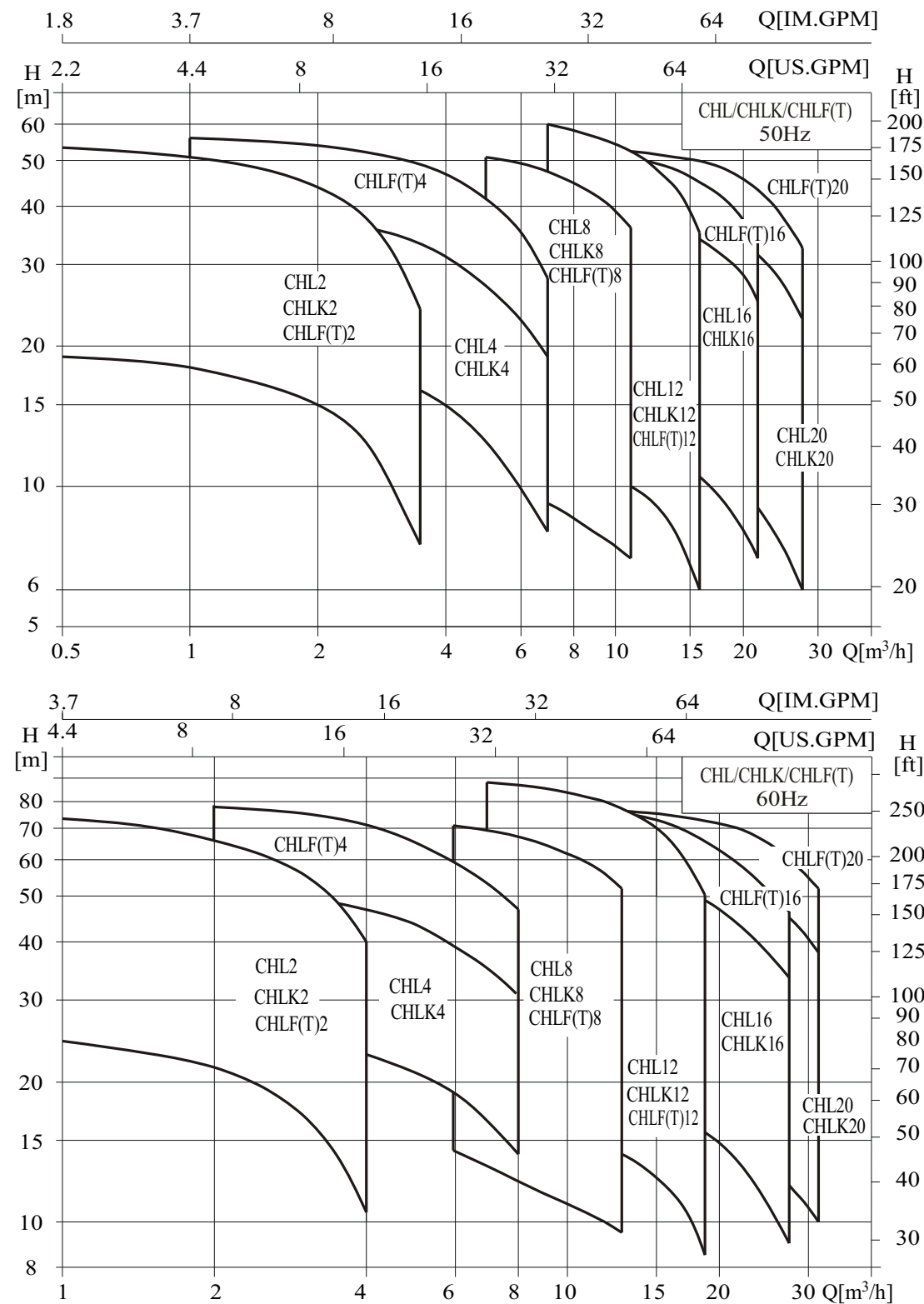

● Application

CHL,CHLK and CHLF(T) type pump are mainly used in industrial field:

- Air-conditioning system
- Cooling system
- Industrial cleaning
- Water treatment (Water purification)
- Aquiculture
- Fertilizing / metering system
- Environmental application
- Other special applications

● Applicable medium

- Thin and clean non-flammable and non-explosive liquid without solid granules and fibers.
- Mineral water, soft water, pure water, edible vegetable oil and other light chemical mediums.
- When the density or viscosity of to-be-conveyed liquid is larger than that of water, it is necessary to select a driving motor of high-power.
- Whether a specific liquid is suitable for the pump depends on many factors, among which the most important ones are chlorine content, PH value, temperature, solvent and oil content.

● Pump

- Horizontal multistage non-self-priming centrifugal pump, attached with long shaft electric motor.
- Compact structure renders small size of pump; axial inlet and radial outlet.

● Curve conditions

Following conditions are suitable for the performance curves shown above.

- All curves are based on the measured values of 50Hz: constant motor speed 2900r/min, 60 Hz: constant motor speed 3500 r/min;
- Curve tolerance in conformity with ISO9906 Annex A.
- Measurement is done with 20°C air-free water, kinematic viscosity of 1mm²/sec.
- The operation of pump shall refer to the performance region described by the thickened curve to prevent overheating due to too small flow rate or overload of motor due to too large flow rate.

● Motor

- TEFC motor 2-pole
- Protection class:IP55
- Insulation class:F
- Standard voltage, 50Hz: 1 × 220-240V
3 × 220-240V/380-415V
- Standard voltage, 60Hz: 1 × 220-240V
3 × 220-240V/380-415V
- Single phase motor (max) : 2.4kW

● Operation condition

- Liquid temperature:
Normal temperature type: -15°C ~ +70°C
Hot water type: -15°C ~ +110°C
- Ambient temperature: up to +40°C
- Max.operation pressure: 10 bar
- Max.inlet pressure is limited by max. Operation pressure

Connection port	CHL/CHLK/CHLF(T)2	CHL/CHLK/CHLF(T)4	CHL/CHLK8, 12,16,20	CHLF(T)8	CHLF(T)12	CHLF(T)16,20
Inlet	G1	G1 1/4	G2	G1 1/2	G1 1/2	G2
Outlet	G1	G1	G2	G1 1/4	G1 1/2	G2

● Definition of Model

CHL Example

CHL 4 - 30
 Stage × 10
 Rated flow m³/h

Light horizontal multistage centrifugal pump
 (Flow passage components stainless steel 304 or 316)

CHLK Example

CHL K 4 - 30
 Stage × 10
 Rated flow m³/h
 Stainless steel air-conditioning pump

Light horizontal multistage centrifugal pump
 (Flow passage components stainless steel 304 or 316)

CHLF(T) Example

CHLF(T) 4 - 30
 Stage × 10
 Rated flow m³/h

Light horizontal multistage centrifugal pump
 (F stands for "section type", T means "Suction and discharge are made of cast iron"; stainless steel, omitted)

● Material CHL/CHLK

No.	Name	Material	AISI / ASTM
1	Inlet and outlet chamber	Stainless steel	AISI304
2	Connection pipe	Stainless steel	AISI304
3	Clamp plate	Stainless steel	AISI304
4	Impeller	Stainless steel	AISI304
5	Shaft	Stainless steel	AISI304
6	Plug	Stainless steel	AISI304
7	Discharge diffuser	Stainless steel	AISI304
8	Mechanical seal		
9	Motor end cover	Aluminum alloy	
10	Base plate	Steel plate	AISI1015
11	Spannband	Stainless steel	AISI304
12	Diffuser	Stainless steel	AISI304
13	Support diffuser	Stainless steel	AISI304
14	Inducer	Stainless steel	AISI304

● Material CHLF/CHLF(T)

No.	Name	Material	AISI / ASTM
2	Plug	Stainless steel	AISI304
3	Bearing	Tungsten carbide	
4	Impeller	Stainless steel	AISI304
5	Shaft	Stainless steel	AISI304
8	Mechanical seal		
9	Motor end cover	Aluminum alloy	
10	Base plate	Steel plate	AISI1015
11	Staybolt	Stainless steel	AISI304
12	Diffuser	Stainless steel	AISI304
13	Support diffuser	Stainless steel	AISI304
14	Impeller sleeve	Stainless steel	AISI304
CHLF			
1	Suction	Stainless steel	AISI304
7	Discharge	Stainless steel	AISI304
CHLF(T)			
1	Suction	Cast iron	ASTM25B
7	Discharge	Cast iron	ASTM25B

● Section drawing CHL,CHLK2,4

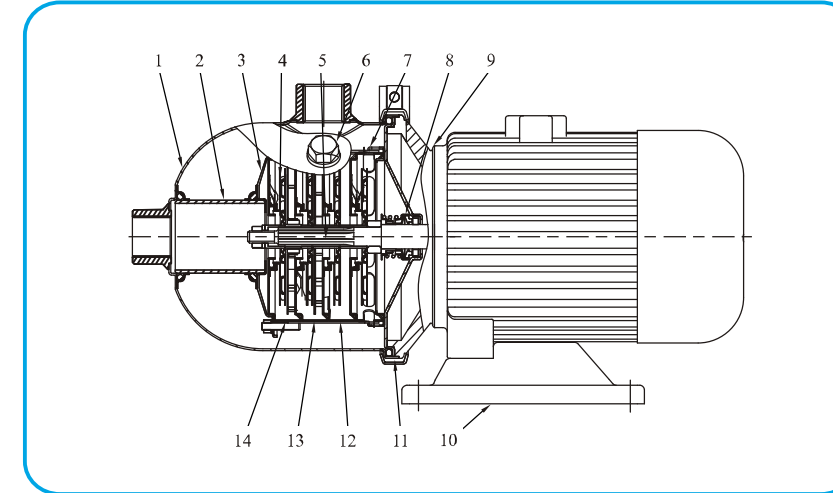

● Section drawing CHL,CHLK8,12,16,20

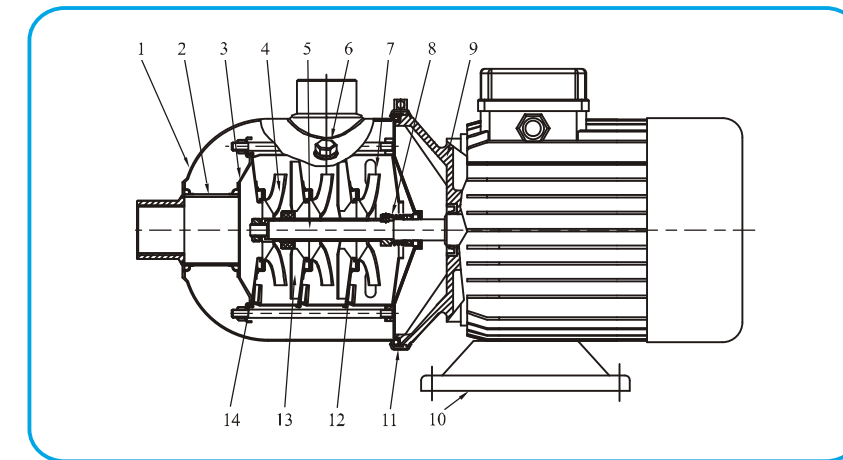

● Section drawing CHLF,CHLF(T)

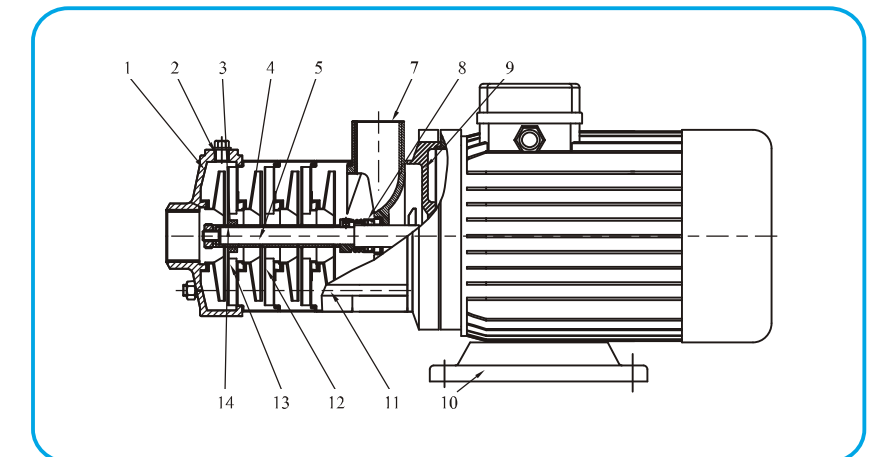

supplierfilterair.com

● Performance curve

ISO9906 Annex A

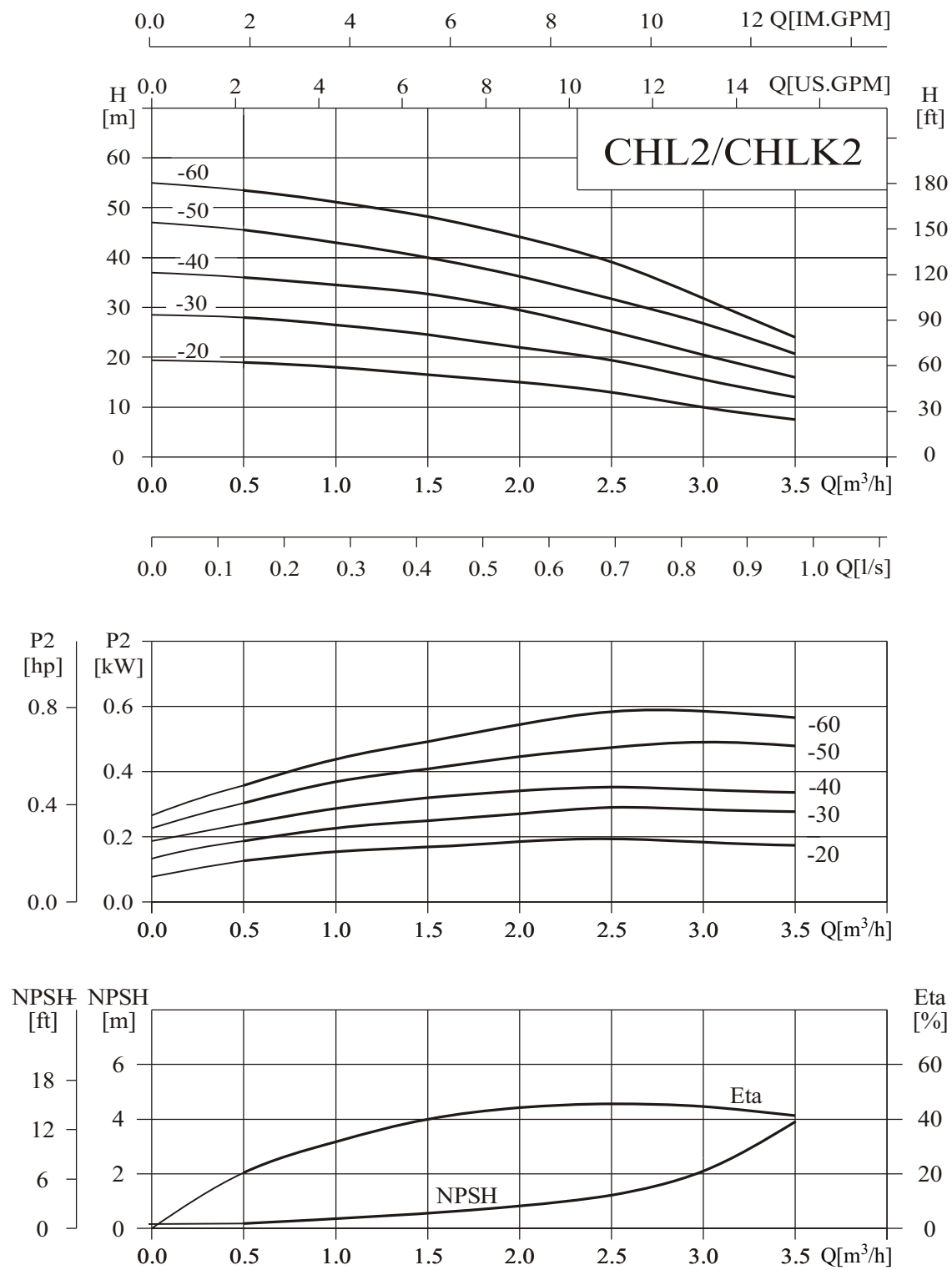

● Performance table

Model	Driving motor		Q (m³/h)	0.5	1	1.5	2	2.5	3	3.5
	(kW)	(hp)								
CHL2-20	0.37	0.5	H (m)	19	18	16.5	15	13	10	7.5
CHL2-30	0.55	0.75		28	26.5	24.5	22	19	15.5	12
CHL2-40	0.55	0.75		36	34.5	33	29	25	20.5	16
CHL2-50	0.55	0.75		45.5	43	40	36	31.5	26.5	20.5
CHL2-60	0.75	1		53.5	51	48	44	39	32	24

● Installation sketch

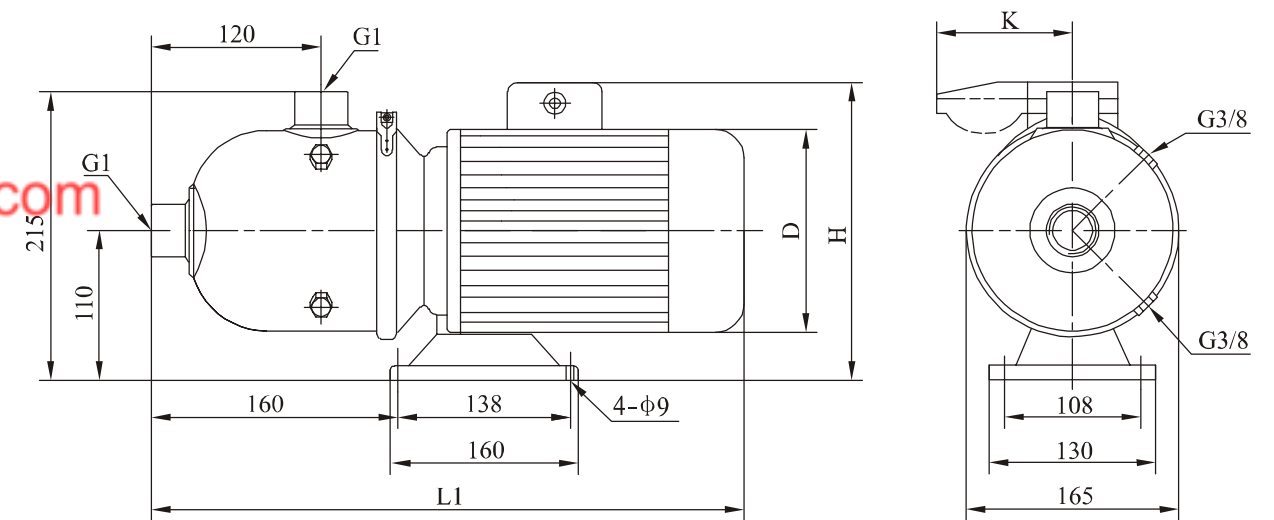

● Size and weight

Motor	Model	Size (mm)				Weight (kg)
		L1	D	H	K	
Three-phase/ single-phase	CHL2-20	400	145	215/230	/96	13
	CHL2-30	400	145	215/230	/96	13
	CHL2-40	400	145	215/230	/96	13
	CHL2-50	400	145	215/230	/96	13
	CHL2-60	445	170	225/245	/100	15

● Performance curve

ISO9906 Annex A

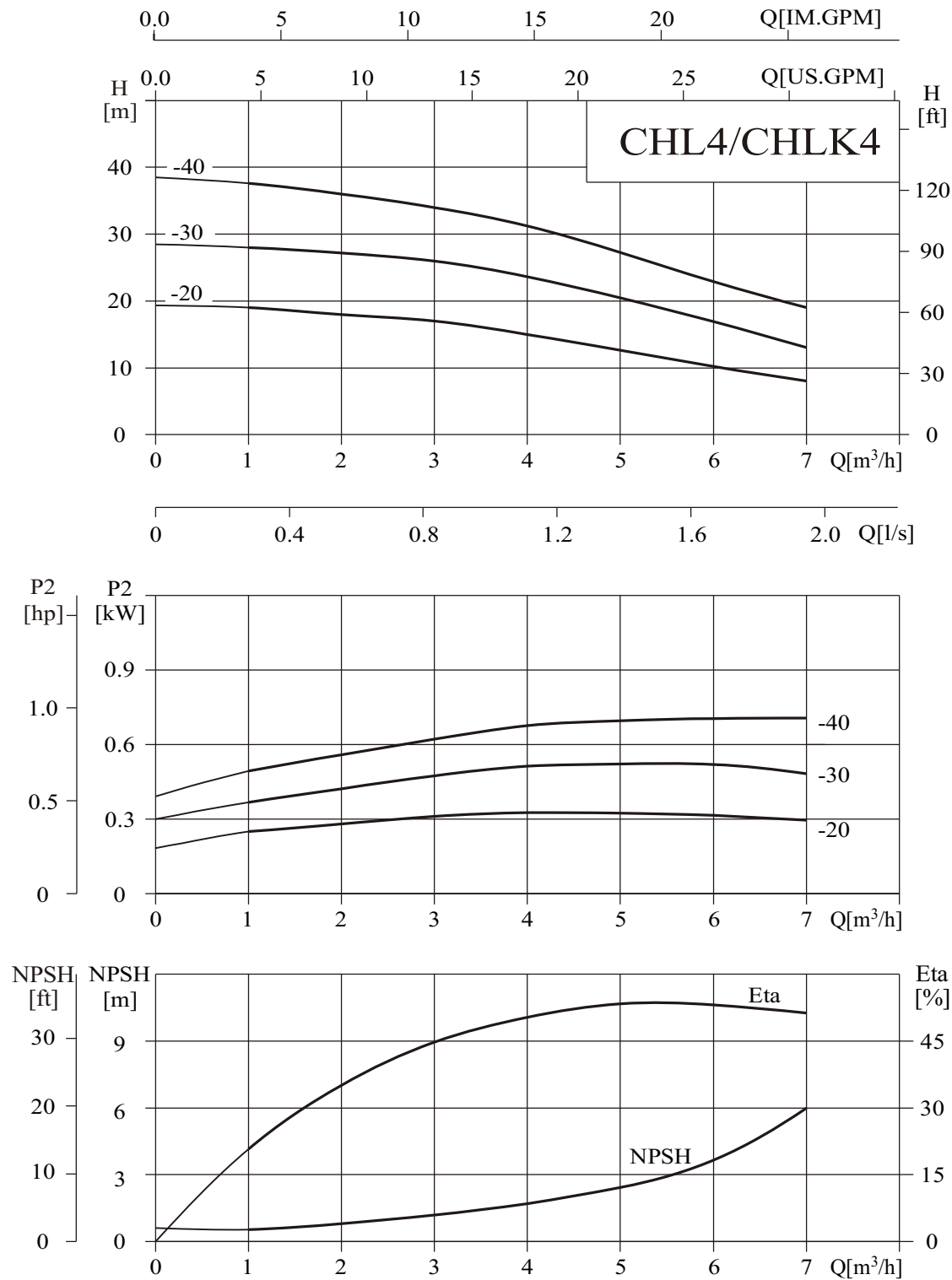

● Performance table

Model	Driving motor		Q (m³/h)	1	2	3	4	5	6	7
	(kW)	(hp)								
CHL4-20	0.55	0.75	H (m)	19	18	17	15	12.5	10	8
CHL4-30	0.75	1		28	27	26	23.5	20.5	17	13
CHL4-40	0.75	1		37.5	36	34	31	27	23	19

● Installation sketch

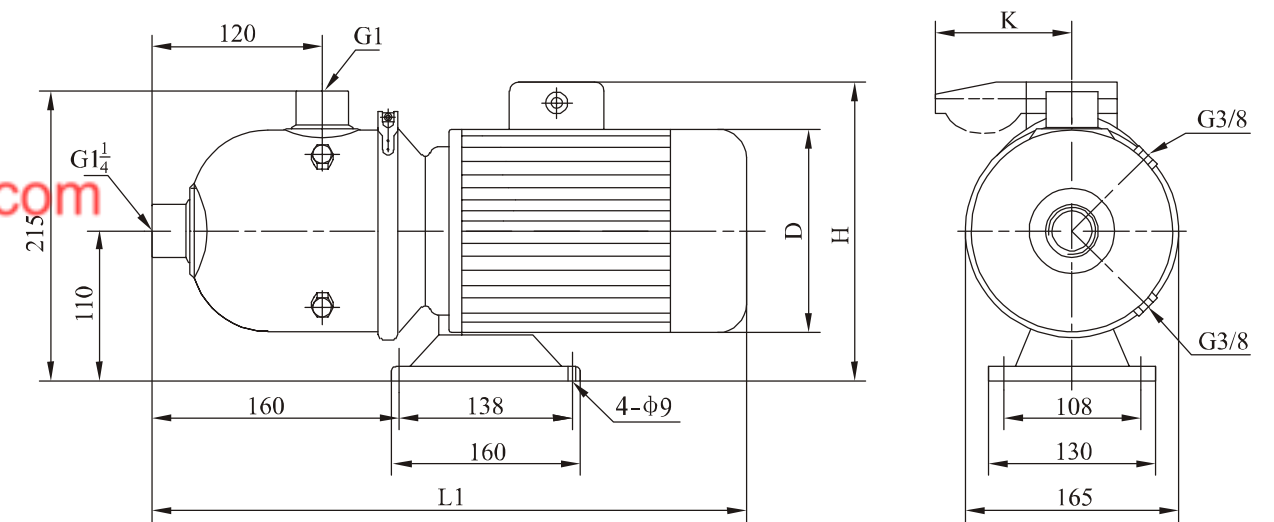

● Size and weight

Motor	Model	Size (mm)				Weight (kg)
		L1	D	H	K	
Three-phase/ single-phase	CHL4-20	400	145	215/230	/96	12
	CHL4-30	445	170	225/245	/100	15
	CHL4-40	445	170	225/245	/100	15

● Performance curve

ISO9906 Annex A

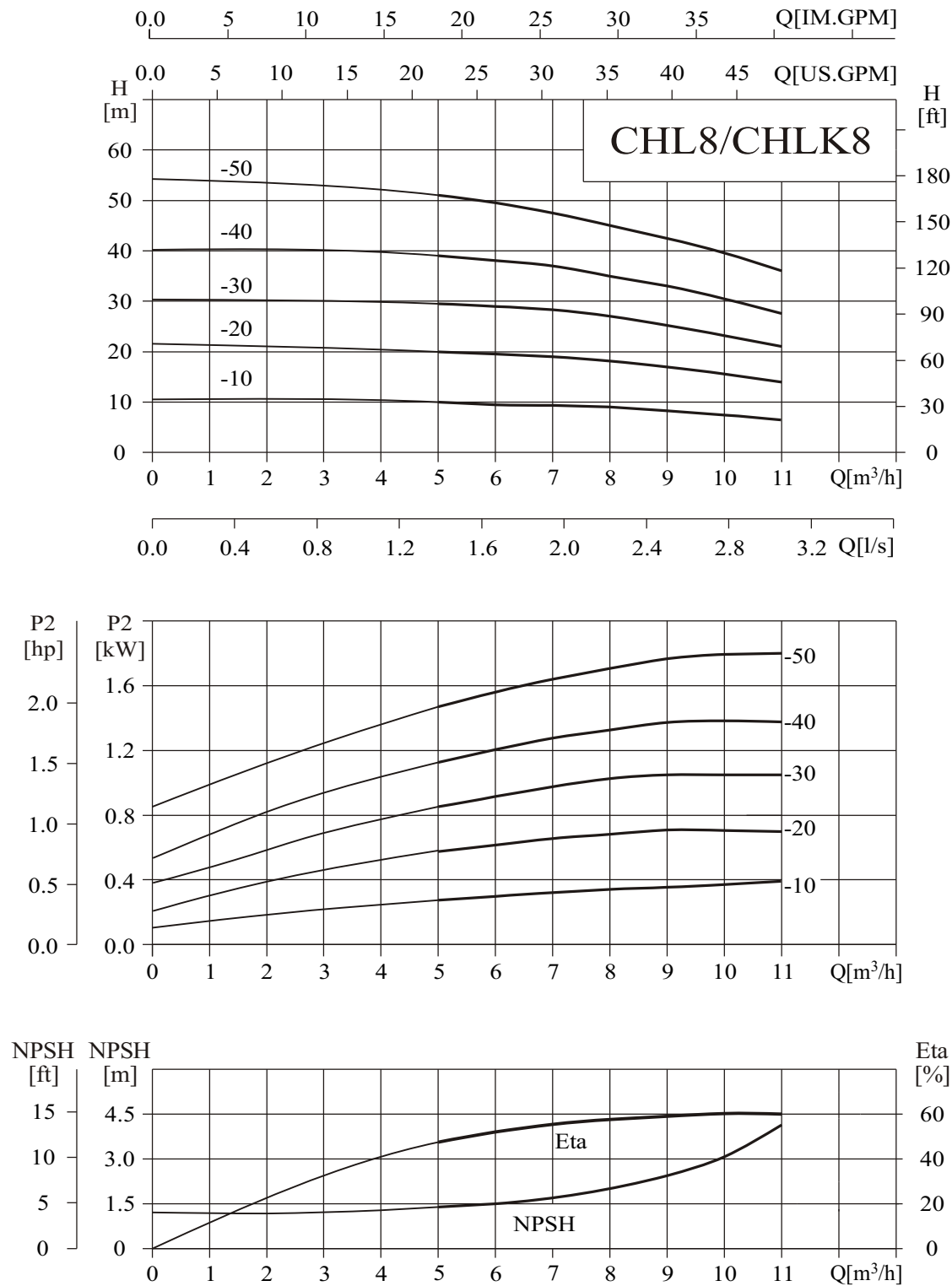

● Performance table

Model	Driving motor		Q (m³/h)	5	6	7	8	9	10	11
	(kW)	(hp)								
CHL8-10	0.75	1	H (m)	10	9.5	9.3	9	8	7.5	7
CHL8-20	0.75	1		20	19.5	19	18	17	15.5	14
CHL8-30	1.1	1.5		29.5	29	28	27	25	23	21
CHL8-40	1.5	2		39	38	37	35	33	30.5	27.5
CHL8-50	2.2	3		51	49.5	47.5	45	42.5	39.5	36

● Installation sketch

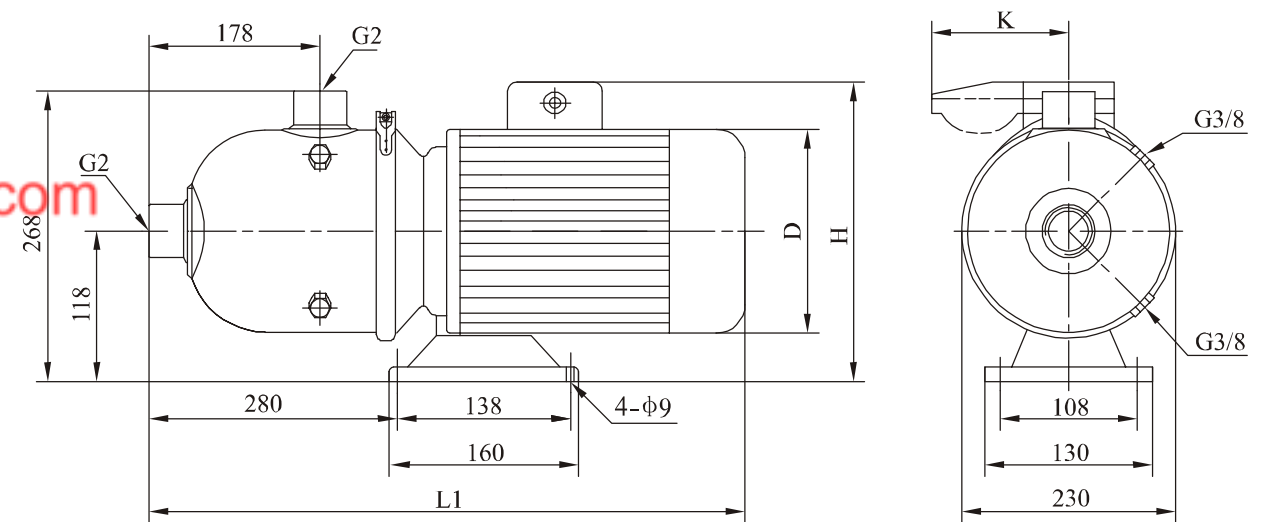

● Size and weight

Motor	Model	Size (mm)				Weight (kg)
		L1	D	H	K	
Three-phase/ single-phase	CHL8-10	560	170	230/265	/100	20
	CHL8-20	560	170	230/265	/100	20
	CHL8-30	560	170	230/265	/100	25
	CHL8-40	580	180	240/270	/100	25
	CHL8-50	580	180	240/270	/100	30

● Performance curve

ISO9906 Annex A

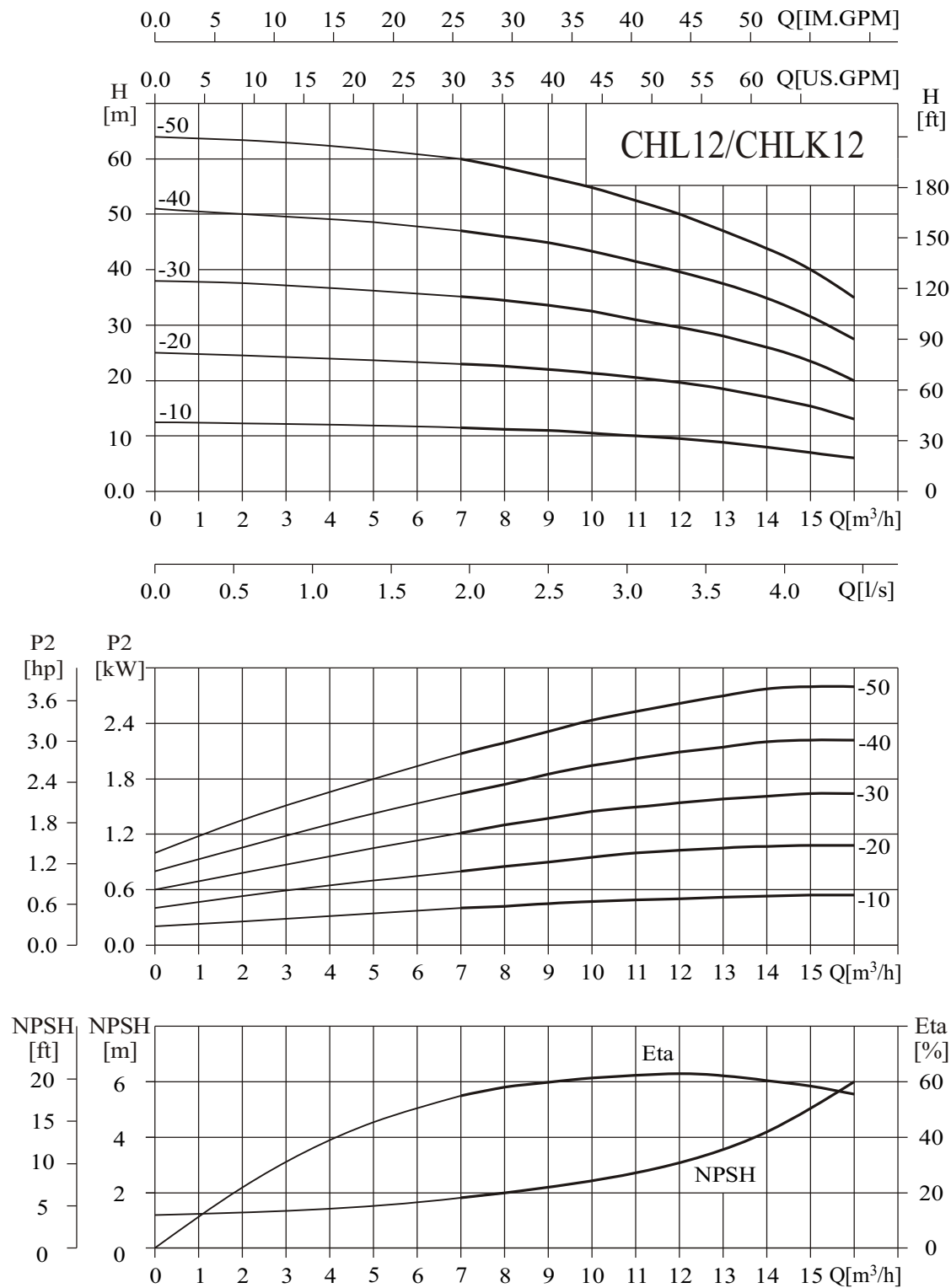

● Performance table

Model	Driving motor		Q (m³/h)	7	8	9	10	11	12	13	14	15	16
	(kW)	(hp)											
CHL12-10	0.75	1	H (m)	11.5	11.2	11	10.5	10	9.5	9	8	7	6
CHL12-20	1.2	1.6		23	22.5	22	21.5	20.5	19.5	18.5	17	15.5	13
CHL12-30	1.8	2.4		35	34.5	33.5	32.5	31	29.5	28	26	23.5	20
CHL12-40	2.4	3.3		47	46	45	43.5	41.5	39.5	37.5	35	31.5	27.5
CHL12-50	3	4		60	58	56.5	55	52.5	50	47	44	40	35

● Installation sketch

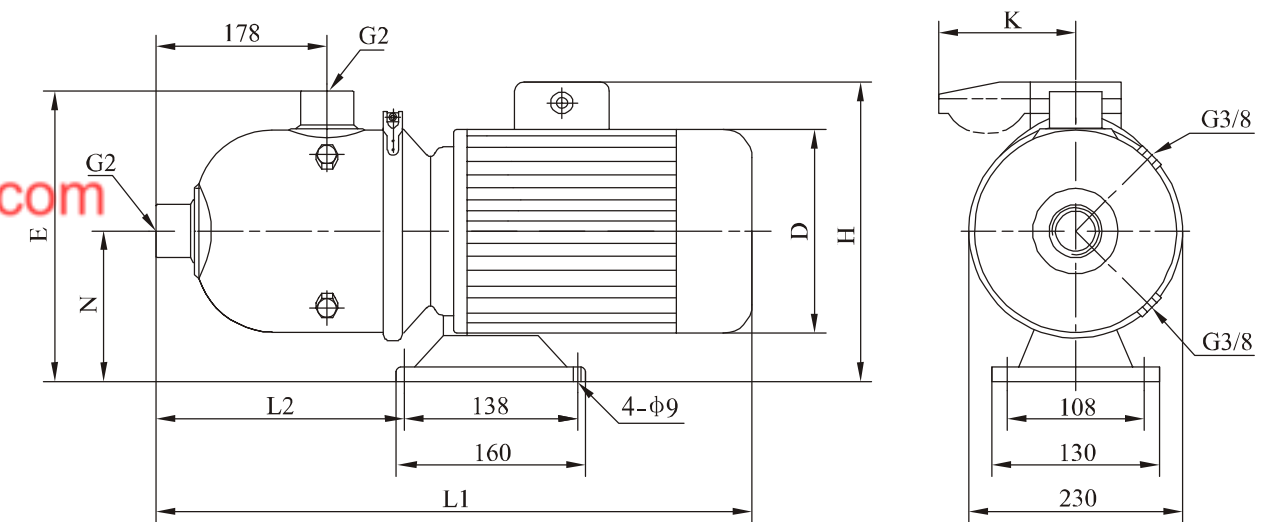

● Size and weight

Motor	Model	Size (mm)							Weight (kg)
		L1	L2	H	D	E	N	K	
Three-phase/ single-phase	CHL12-10	560	280	230/265	170	268	118	/100	20
	CHL12-20	560	280	230/265	170	268	118	/100	21
	CHL12-30	580	280	240/270	180	268	118	/100	25
	CHL12-40	580	280	240/270	180	268	118	/100	29
	CHL12-50	610	270	270/	195	276	126		34

● Performance curve

ISO9906 Annex A

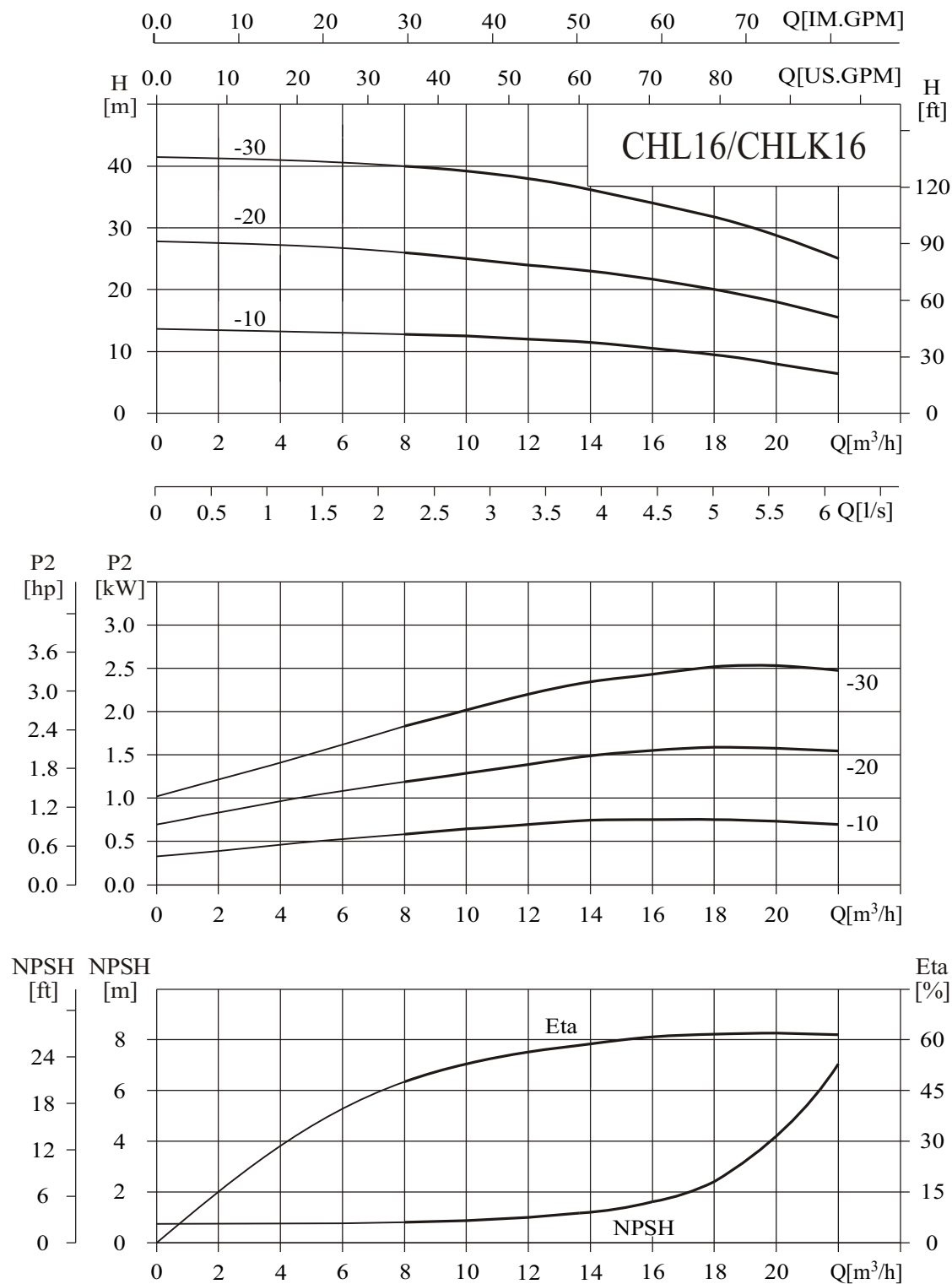

● Performance table

Model	Driving motor		Q (m³/h)	8	10	12	14	16	18	20	22
	(kW)	(hp)									
CHL16-10	1.1	1.5	H (m)	12.8	12.5	12	11.5	10.5	9.5	8	7
CHL16-20	2.2	3		26	25	24	23	21.7	20	18	15.5
CHL16-30	3	4		40	39	38	36	34	31.5	29	25

● Installation sketch

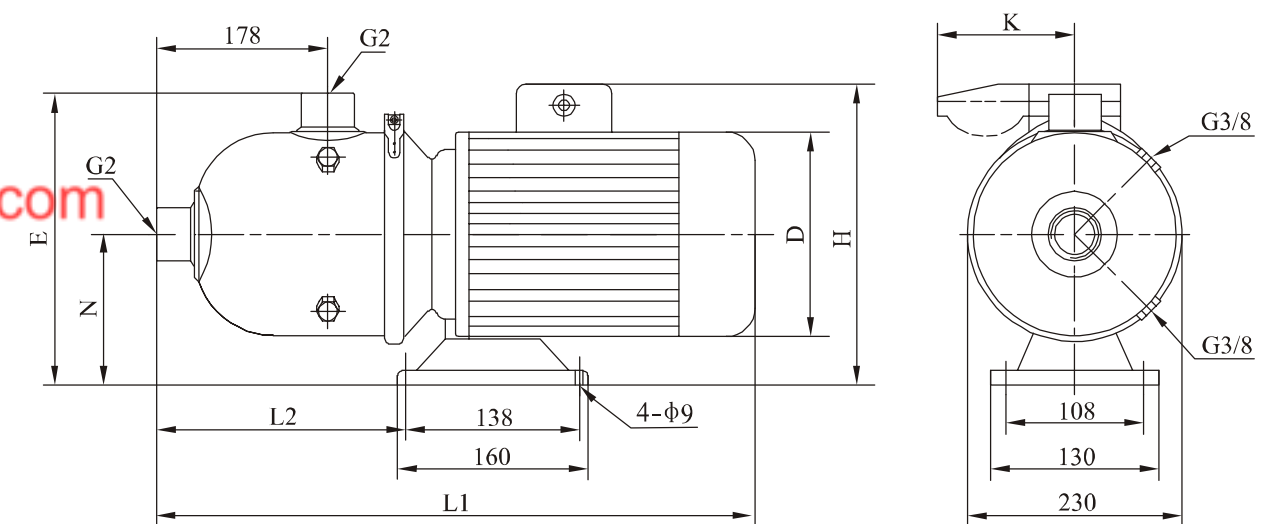

● Size and weight

Motor	Model	Size (mm)							Weight (kg)
		L1	L2	E	N	D	H	K	
Three-phase/ single-phase	CHL16-10	560	280	268	118	170	230/265	/100	20
	CHL16-20	580	280	268	118	180	240/270	/100	27
	CHL16-30	610	270	276	126	195	270/		34

● Performance curve

ISO9906 Annex A

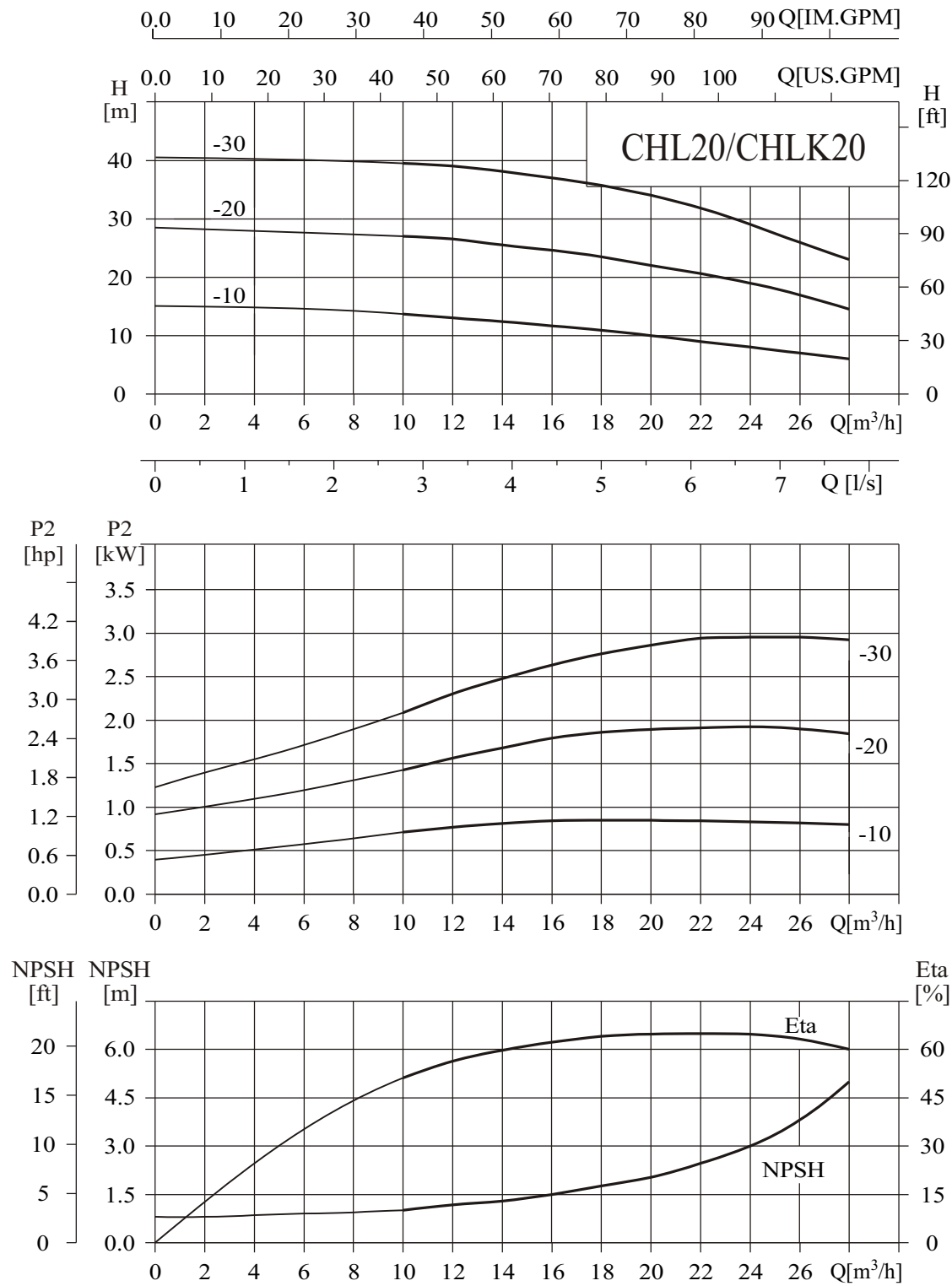

● Performance table

Model	Driving motor		Q (m³/h)	10	12	14	16	18	20	22	24	26	28
	(kW)	(hp)											
CHL20-10	1.1	1.5	H (m)	13.5	13	12.5	12	11	10	9	8	7	6
CHL20-20	2.2	3		27	26.5	25.5	25	23.5	22	20.5	18.5	17	14.5
CHL20-30	4	5.5		39.5	39	38	37.5	35.5	34	31.5	29	26	23

● Installation sketch

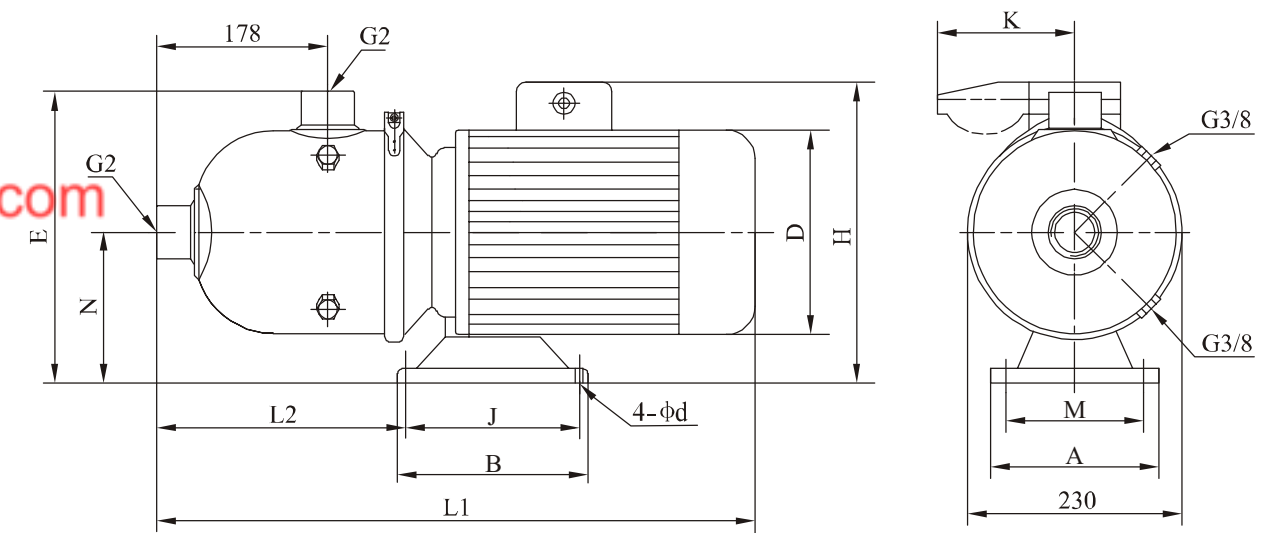

● Size and weight

Motor	Model	Size (mm)												Weight (kg)
		L1	L2	H	D	E	N	A	M	B	J	d	K	
Three-phase/ single-phase	CHL20-10	560	280	230/265	170	268	118	130	108	160	138	9	/100	21
	CHL20-20	580	280	240/270	180	268	118	130	108	160	138	9	/100	28
	CHL20-30	650	360	270/	220	270	120	230	190	170	140	12		42

● Performance curve

ISO9906 Annex A

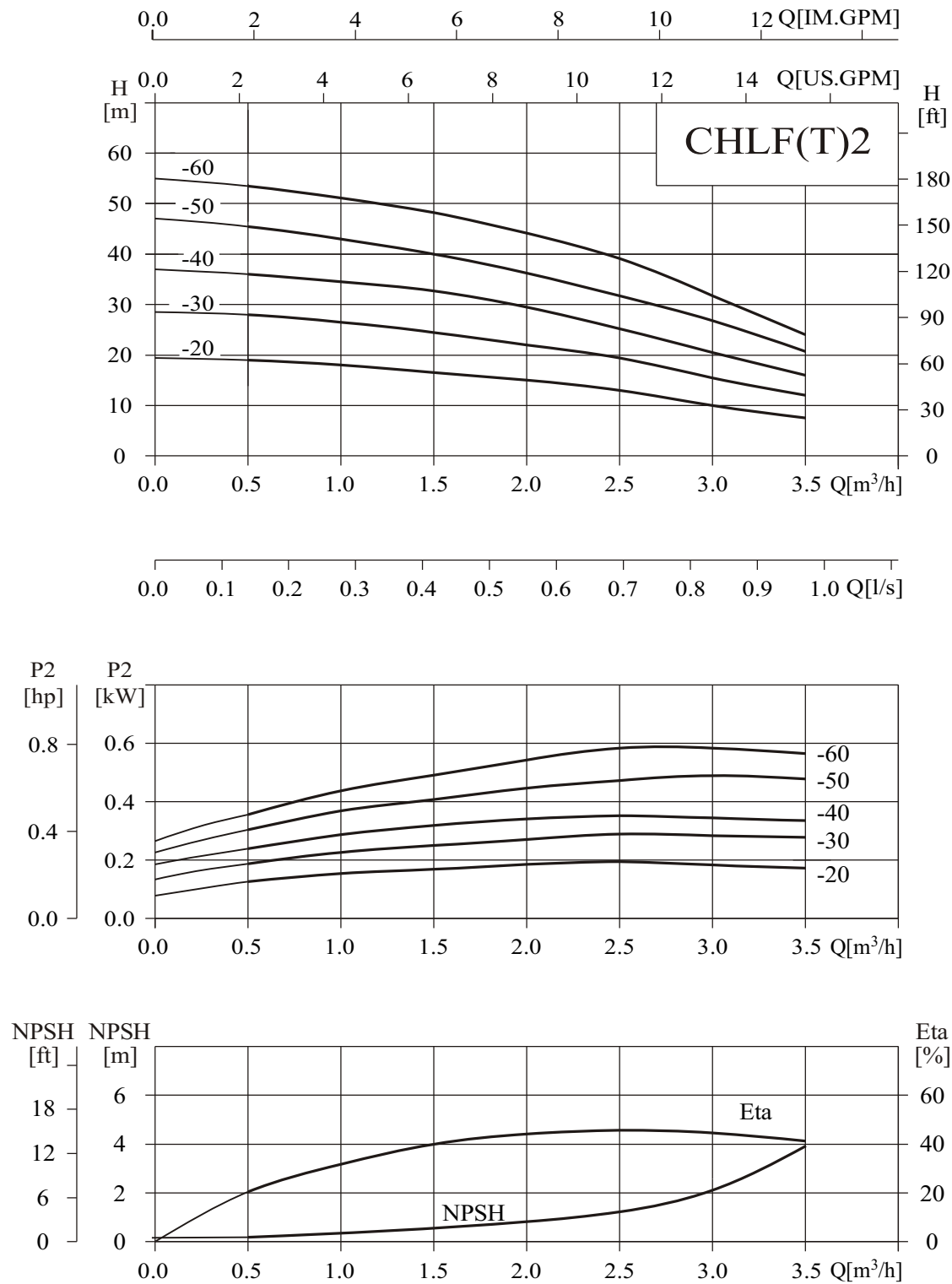

● Performance table

Model	Driving motor		Q (m³/h)	0.5	1	1.5	2	2.5	3	3.5
	(kW)	(hp)								
CHLF(T)2-20	0.37	0.5	H (m)	19	18	16.5	15	13	10	7.5
CHLF(T)2-30	0.55	0.75		28	26.5	24.5	22	19	15.5	12
CHLF(T)2-40	0.55	0.75		36	34.5	33	29	25	20.5	16
CHLF(T)2-50	0.55	0.75		45.5	43	40	36	31.5	26.5	20.5
CHLF(T)2-60	0.75	1		53.5	51	48	44	39	32	24

● Installation sketch

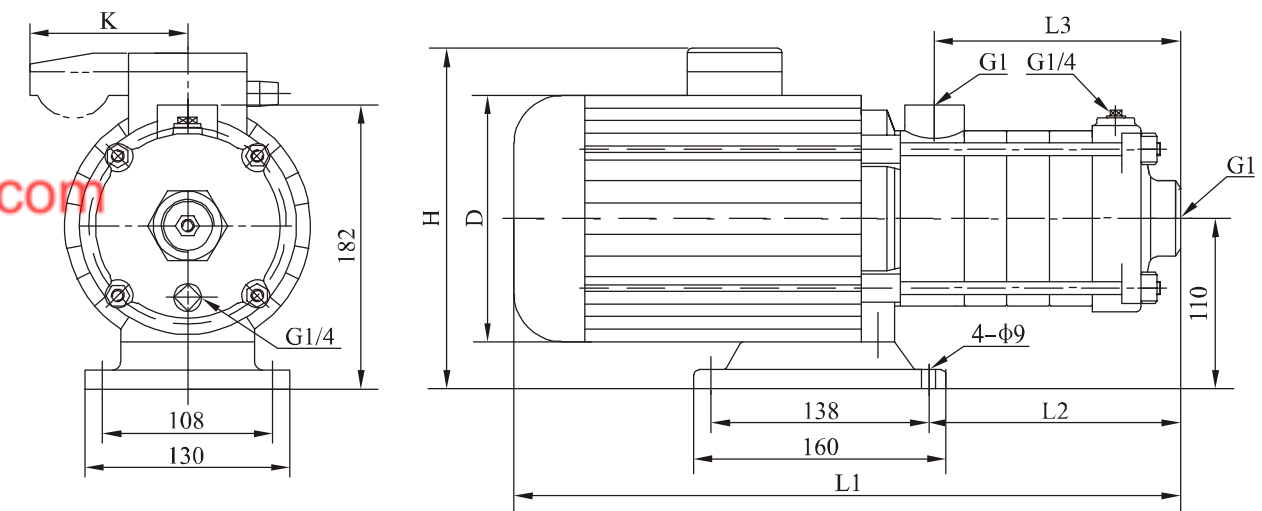

● Size and weight

Motor	Model	Size (mm)						Weight (kg)
		L1	L2	L3	D	H	K	
Three-phase/ single-phase	CHLF(T)2-20	305	87	84	145	215/230	/96	15
	CHLF(T)2-30	323	105	102	145	215/230	/96	15
	CHLF(T)2-40	341	123	120	145	215/230	/96	15
	CHLF(T)2-50	359	141	138	145	215/230	/96	15
	CHLF(T)2-60	422	159	156	170	225/245	/100	17

● Performance curve

ISO9906 Annex A

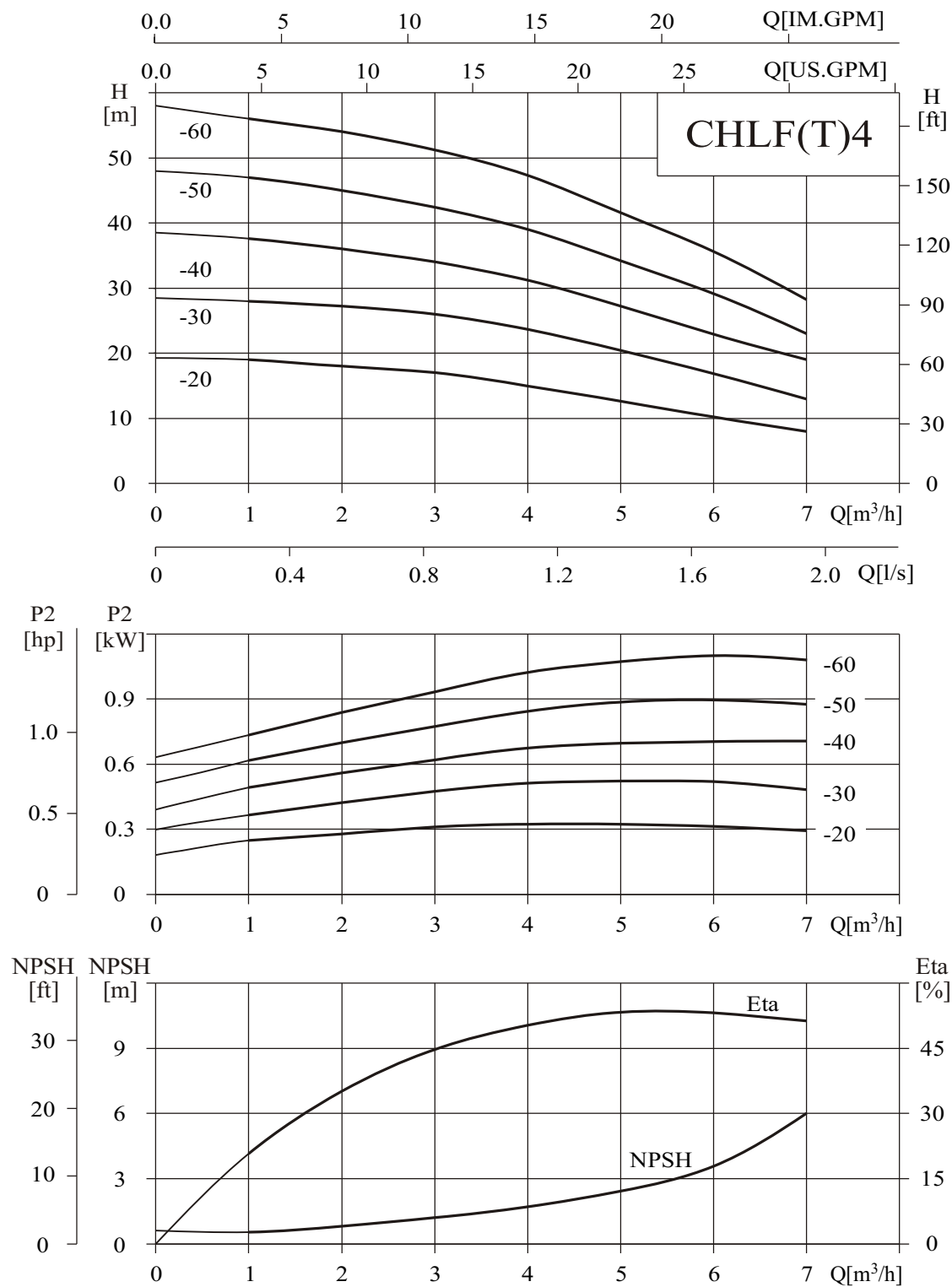

● Performance table

Model	Driving motor		Q (m³/h)	1	2	3	4	5	6	7
	(kW)	(hp)								
CHLF(T)4-20	0.55	0.75	H (m)	19	18	17	15	12.5	10	8
CHLF(T)4-30	0.55	0.75		28	27	26	23.5	20.5	17	13
CHLF(T)4-40	0.75	1		37.5	36	34	31	27	23	19
CHLF(T)4-50	1.1	1.5		47	45	42.5	39	34	29	23
CHLF(T)4-60	1.1	1.5		56	54	51	47	41.5	35.5	28

● Installation sketch

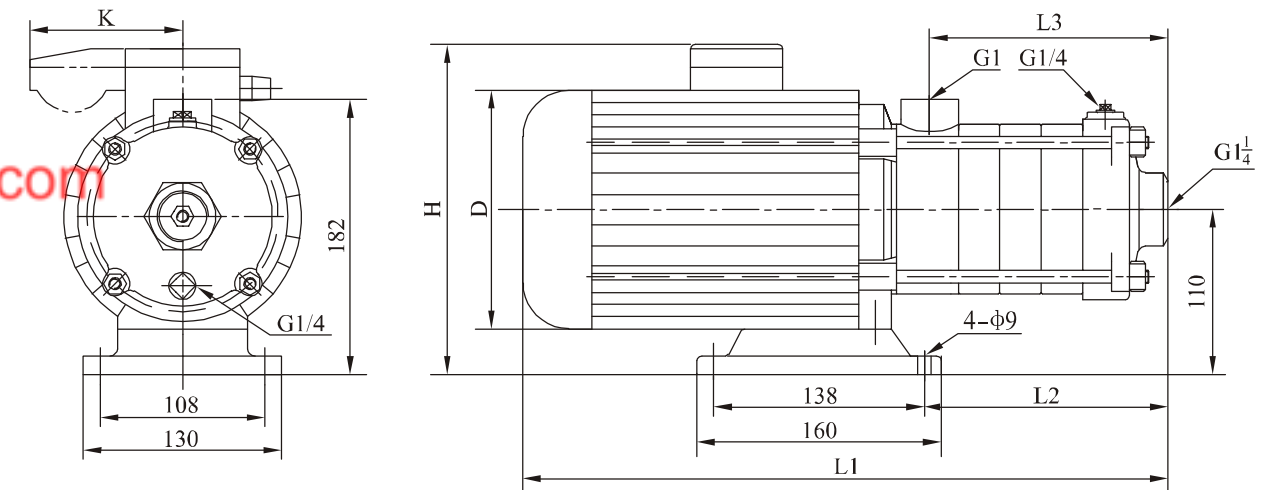

● Size and weight

Motor	Model	Size (mm)						Weight (kg)
		L1	L2	L3	D	H	K	
Three-phase/ single-phase	CHLF(T)4-20	329	105	102	145	215/230	/96	15
	CHLF(T)4-30	356	132	129	145	215/230	/96	15
	CHLF(T)4-40	416	162	156	170	225/245	/100	17
	CHLF(T)4-50	455	188	183	170	225/245	/100	17
	CHLF(T)4-60	482	213	210	170	225/245	/100	17

● Performance curve

ISO9906 Annex A

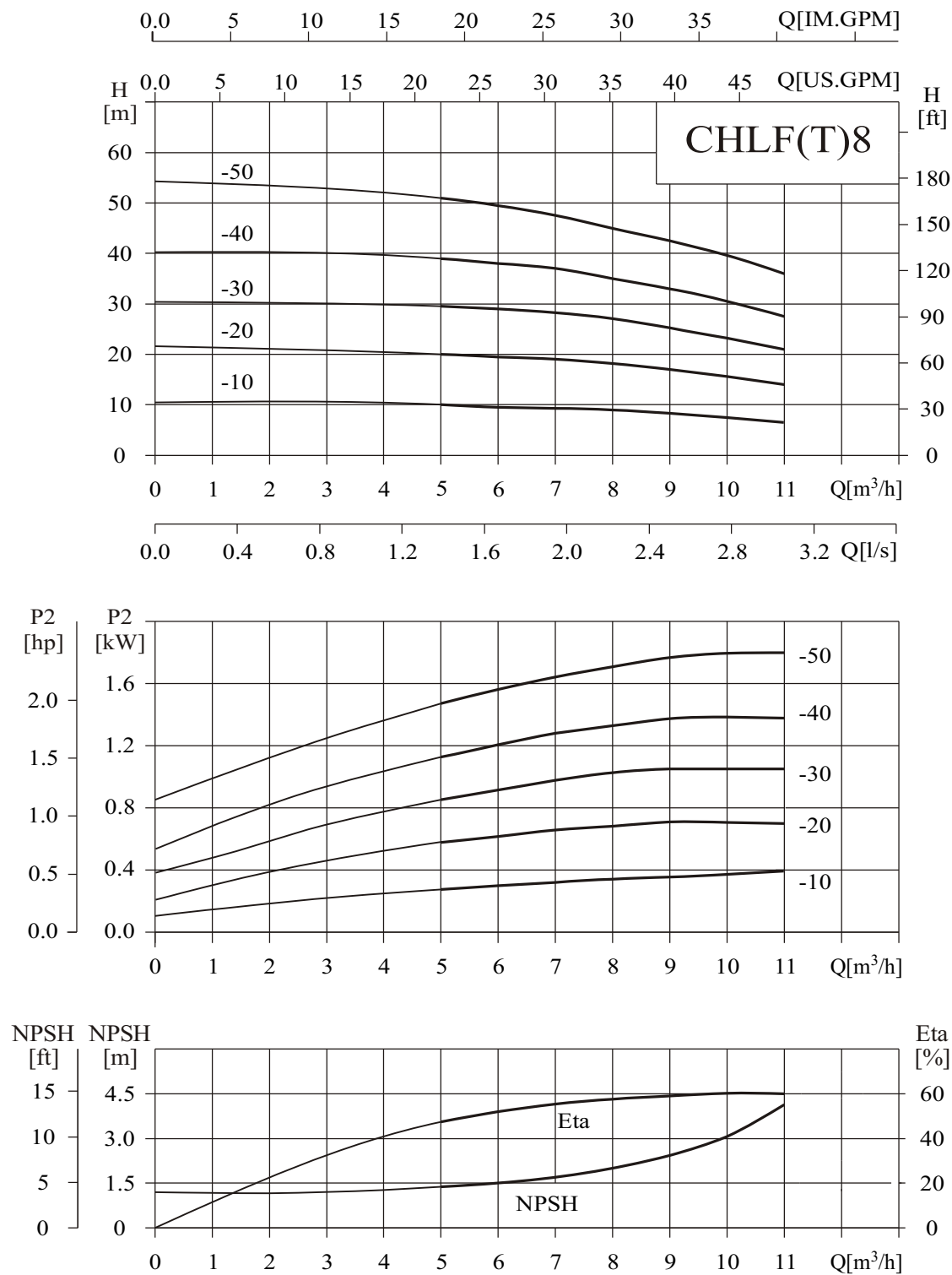

● Performance table

Model	Driving motor		Q (m³/h)	5	6	7	8	9	10	11
	(kW)	(hp)								
CHLF(T)8-10	0.75	1	H (m)	10	9.5	9.3	9	8	7.5	7
CHLF(T)8-20	0.75	1		20	19.5	19	18	17	15.5	14
CHLF(T)8-30	1.1	1.5		29.5	29	28	27	25	23	21
CHLF(T)8-40	1.5	2		39	38	37	35	33	30.5	27.5
CHLF(T)8-50	2.2	3		51	49.5	47.5	45	42.5	39.5	36

● Installation sketch

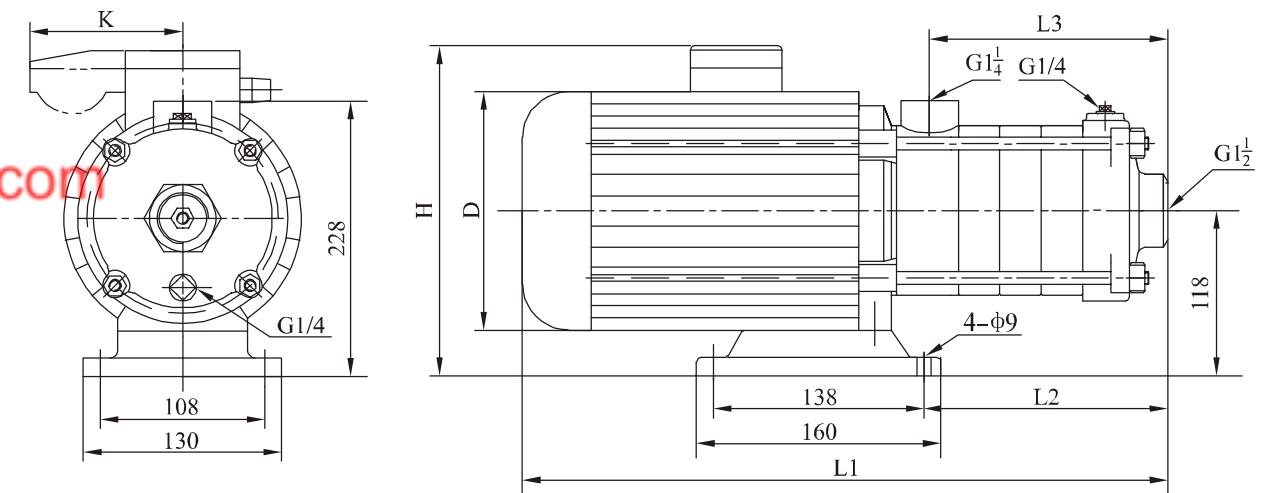

● Size and weight

Motor	Model	Size (mm)						Weight (kg)
		L1	L2	L3	D	H	K	
Three-phase/ single-phase	CHLF(T)8-10	395	126	108	170	230/265	/100	20
	CHLF(T)8-20	395	126	108	170	230/265	/100	20
	CHLF(T)8-30	425	156	138	170	230/265	/100	25
	CHLF(T)8-40	490	186	168	180	240/270	/100	28
	CHLF(T)8-50	520	216	198	180	240/270	/100	30

● Performance curve

ISO9906 Annex A

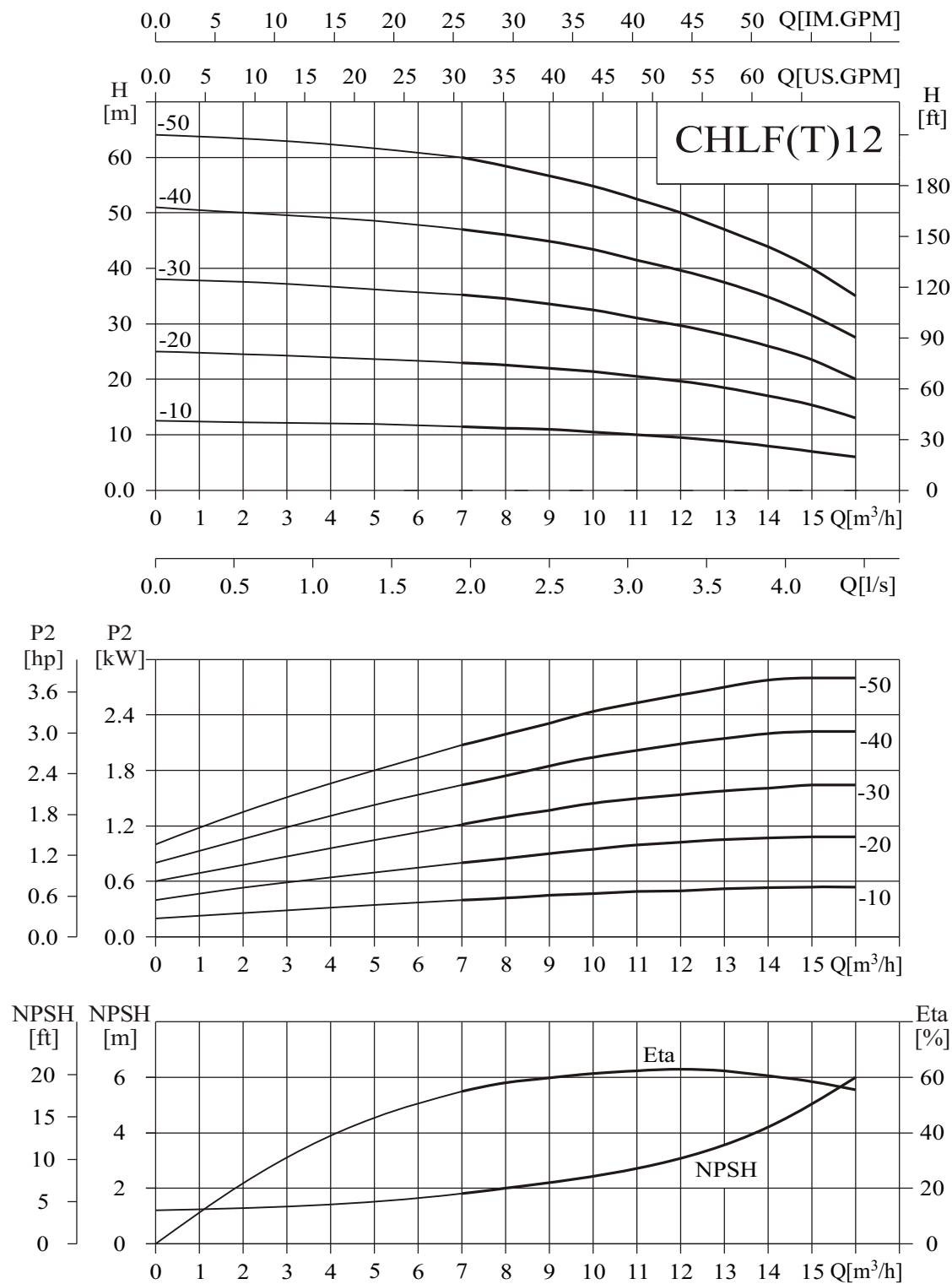

● Performance table

Model	Driving motor		Q (m³/h)	7	8	9	10	11	12	13	14	15	16
	(kW)	(hp)											
CHLF(T)12-10	0.75	1	H (m)	11.5	11.2	11	10.5	10	9.5	9	8	7	6
CHLF(T)12-20	1.2	1.6		23	22.5	22	21.5	20.5	19.5	18.5	17	15.5	13
CHLF(T)12-30	1.8	2.4		35	34.5	33.5	32.5	31	29.5	28	26	23.5	20
CHLF(T)12-40	2.4	3.3		47	46	45	43.5	41.5	39.5	37.5	35	31.5	27.5
CHLF(T)12-50	3	4		60	58	56.5	55	52.5	50	47	44	40	35

● Installation sketch

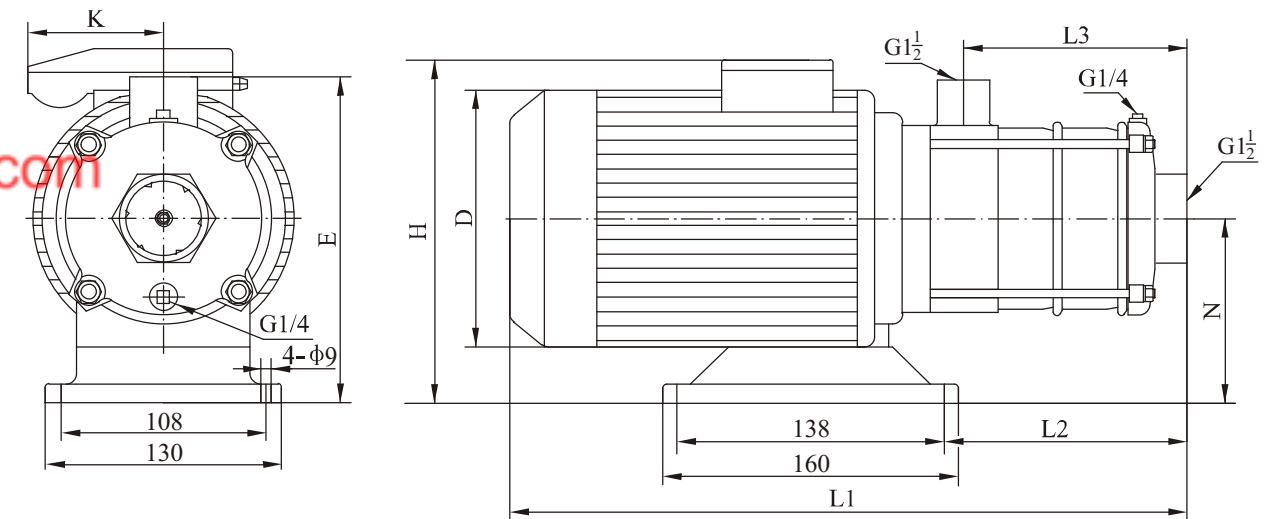

● Size and weight

Motor	Model	Size (mm)								Weight (kg)
		L1	L2	L3	H	D	E	N	K	
Three-phase/ single-phase	CHLF(T)12-10	395	126	108	230/265	170	228	118	/100	20
	CHLF(T)12-20	395	126	108	230/265	170	228	118	/100	21
	CHLF(T)12-30	460	156	138	240/270	180	228	118	/100	25
	CHLF(T)12-40	490	186	168	240/270	180	228	118	/100	29
	CHLF(T)12-50	555	216	198	270/	195	240	126		34

● Performance curve

ISO9906 Annex A

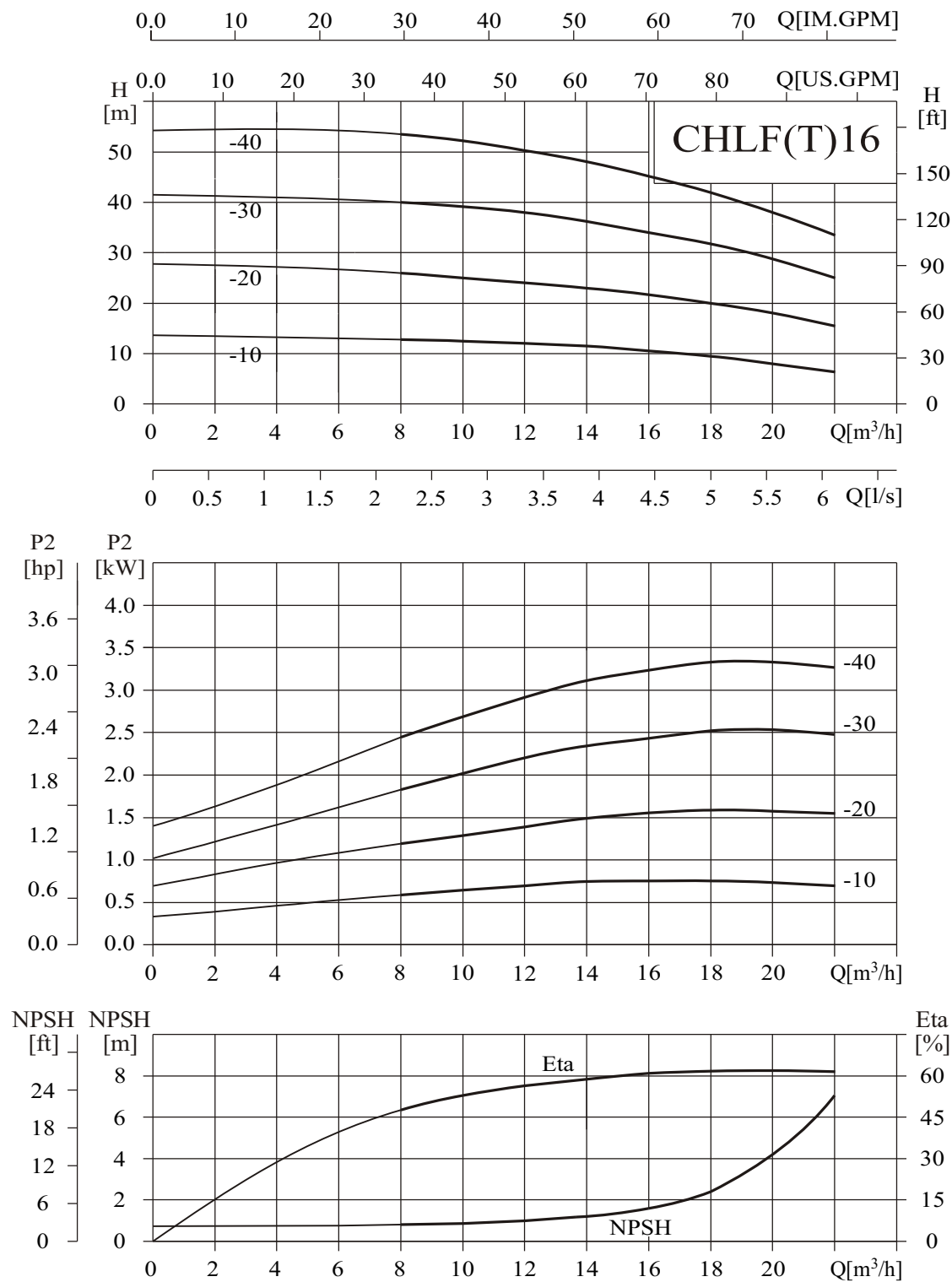

● Performance table

Model	Driving motor		Q (m³/h)	8	10	12	14	16	18	20	22
	(kW)	(hp)									
CHLF(T)16-10	1.1	1.5	H (m)	12.8	12.5	12	11.5	10.5	9.5	8	7
CHLF(T)16-20	2.2	3		26	25	24	23	21.7	20	18	15.5
CHLF(T)16-30	3	4		40	39	38	36	34	31.5	29	25
CHLF(T)16-40	4	5.5		53.5	52	50	48	45	42	38	33.5

● Installation sketch

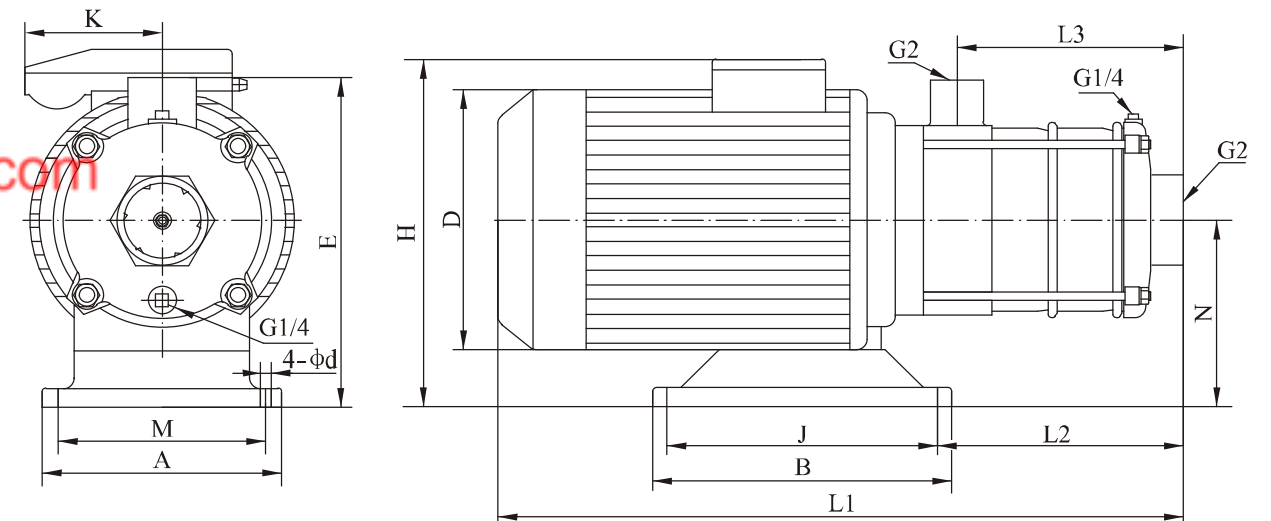

● Size and weight

Motor	Model	Size (mm)												Weight (kg)	
		L1	L2	L3	H	D	E	N	A	M	B	J	d		K
Three-phase/ single-phase	CHLF(T)16-10	423	151	126	230/265	170	227	117	130	108	160	138	9	/100	17.5
	CHLF(T)16-20	455	151	126	240/270	180	228	118	130	108	160	138	9	/100	27
	CHLF(T)16-30	561	196	171	270/	195	240	130	130	108	160	138	9		33
	CHLF(T)16-40	621	340	216	270/	220	230	120	230	190	170	140	12		41

● Performance curve

ISO9906 Annex A

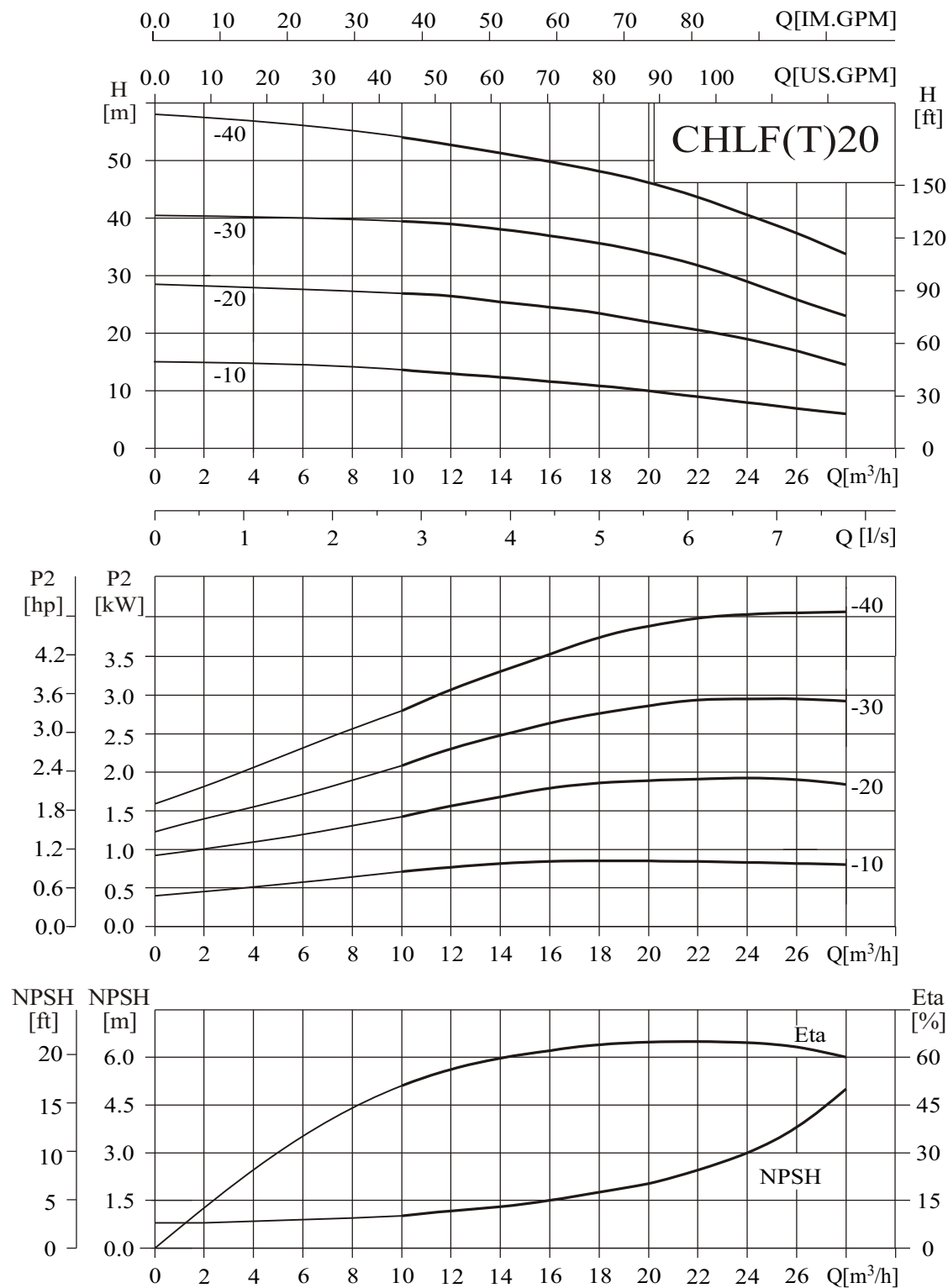

● Performance table

Model	Driving motor		Q (m³/h)	10	12	14	16	18	20	22	24	26	28
	(kW)	(hp)		H (m)									
CHLF(T)20-10	1.1	1.5	H (m)	13.5	13	12.5	12	11	10	9	8	7	6
CHLF(T)20-20	2.2	3		27	26.5	25.5	25	23.5	22	20.5	18.5	17	14.5
CHLF(T)20-30	4	5.5		39.5	39	38	37.5	35.5	34	31.5	29	26	23
CHLF(T)20-40	4.4	6		53	52	51	50	48.5	46.5	43	40	36	32.5

● Installation sketch

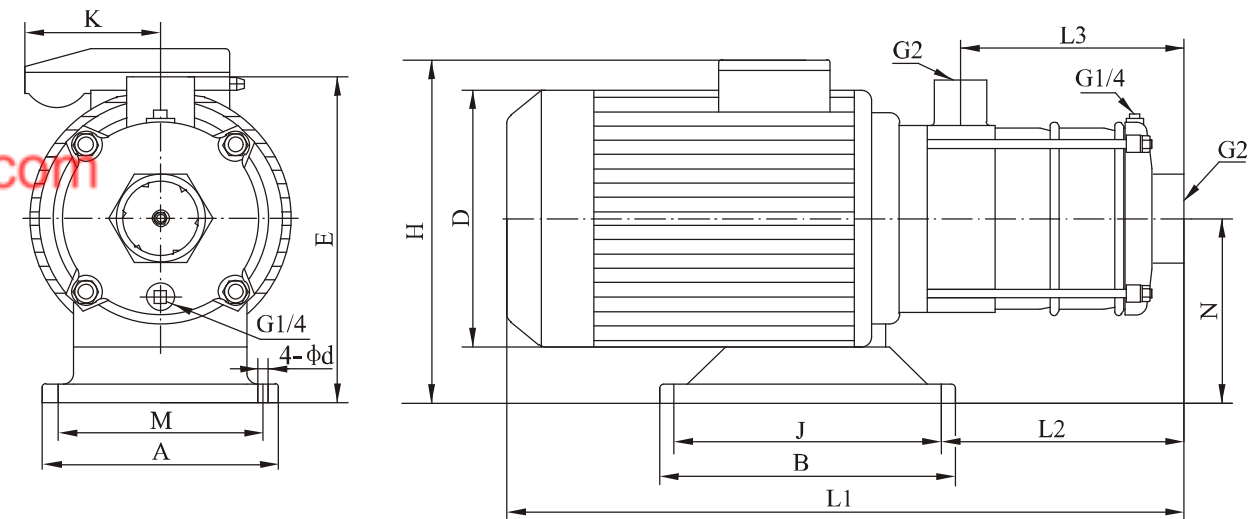

● Size and weight

Motor	Model	Size (mm)													Weight (kg)
		L1	L2	L3	H	D	E	N	A	M	B	J	d	K	
Three-phase/ single-phase	CHLF(T)20-10	423	151	126	230/265	170	227	117	130	108	160	138	9	/100	17.5
	CHLF(T)20-20	455	151	126	240/270	180	228	118	130	108	160	138	9	/100	27
	CHLF(T)20-30	576	294	171	270/	220	230	120	230	190	170	140	12		41
	CHLF(T)20-40	621	340	216	270/	220	230	120	230	190	170	140	12		44

● Performance curve

ISO9906 Annex A

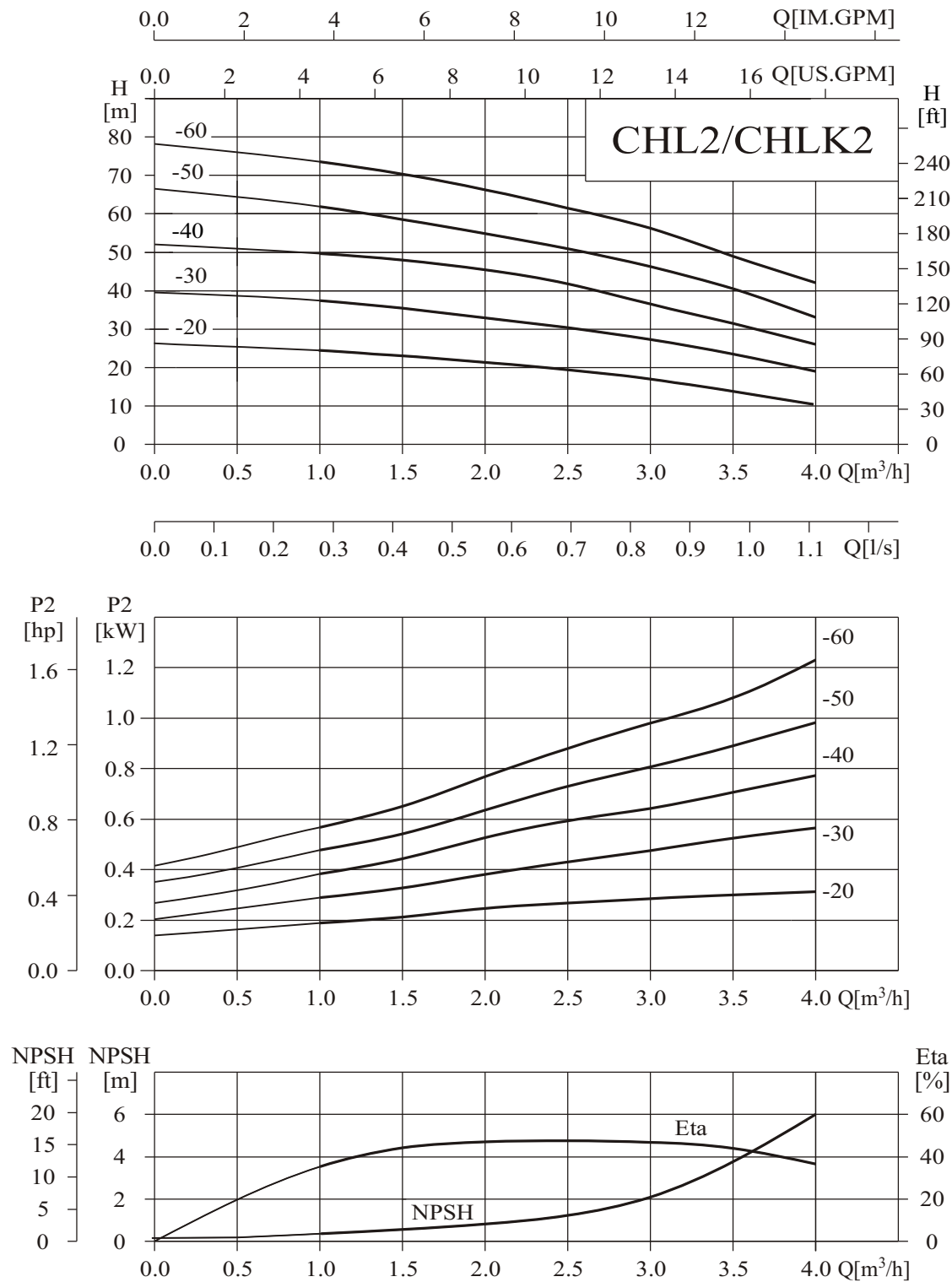

● Performance table

Model	Driving motor		Q (m³/h)	1	1.5	2	2.5	3	3.5	4
	(kW)	(hp)								
CHL2-20	0.55	0.75	H (m)	24.5	23	21.5	19.5	17	14	10.5
CHL2-30	0.75	1		37.5	35.5	33	30.5	27.5	23.5	19
CHL2-40	1.1	1.5		49.5	48	45.5	42	36	32	26
CHL2-50	1.1	1.5		62	58.5	55	51	46	40.5	33
CHL2-60	1.5	2		73.5	70.5	66	61.5	56	49	40

● Installation sketch

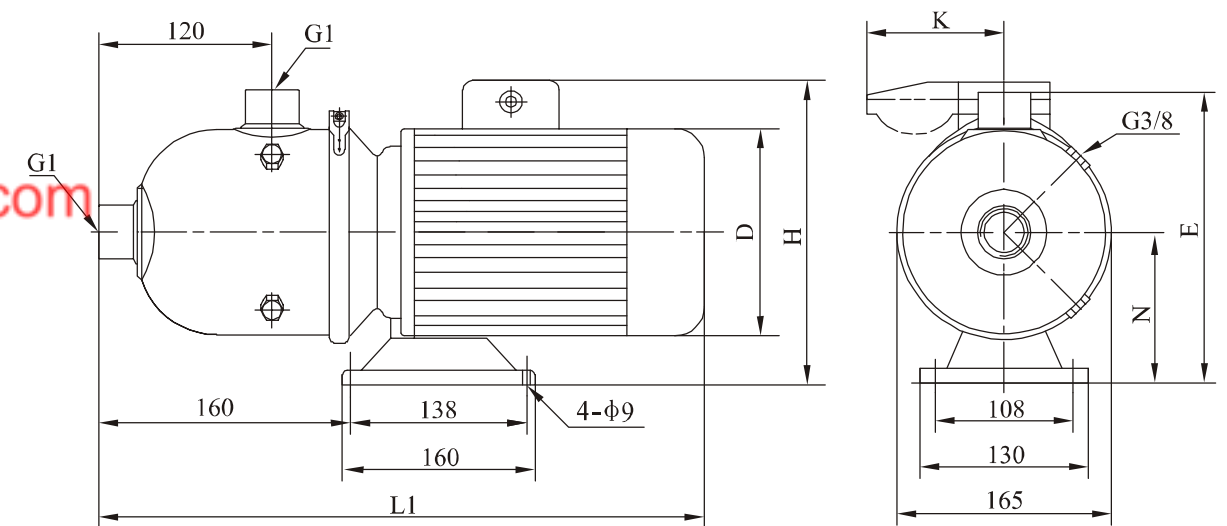

● Size and weight

Motor	Model	Size (mm)						Weight (kg)
		L1	H	N	D	E	K	
Three-phase/ single-phase	CHL2-20	400	215/230	110	145	210	/96	13
	CHL2-30	420	220/245	110	160	210	/100	13
	CHL2-40	420	230/245	110	170	210	/100	15
	CHL2-50	420	230/245	110	170	210	/100	15
	CHL2-60	470	240/260	118	170	218	/100	20

● Performance curve

ISO9906 Annex A

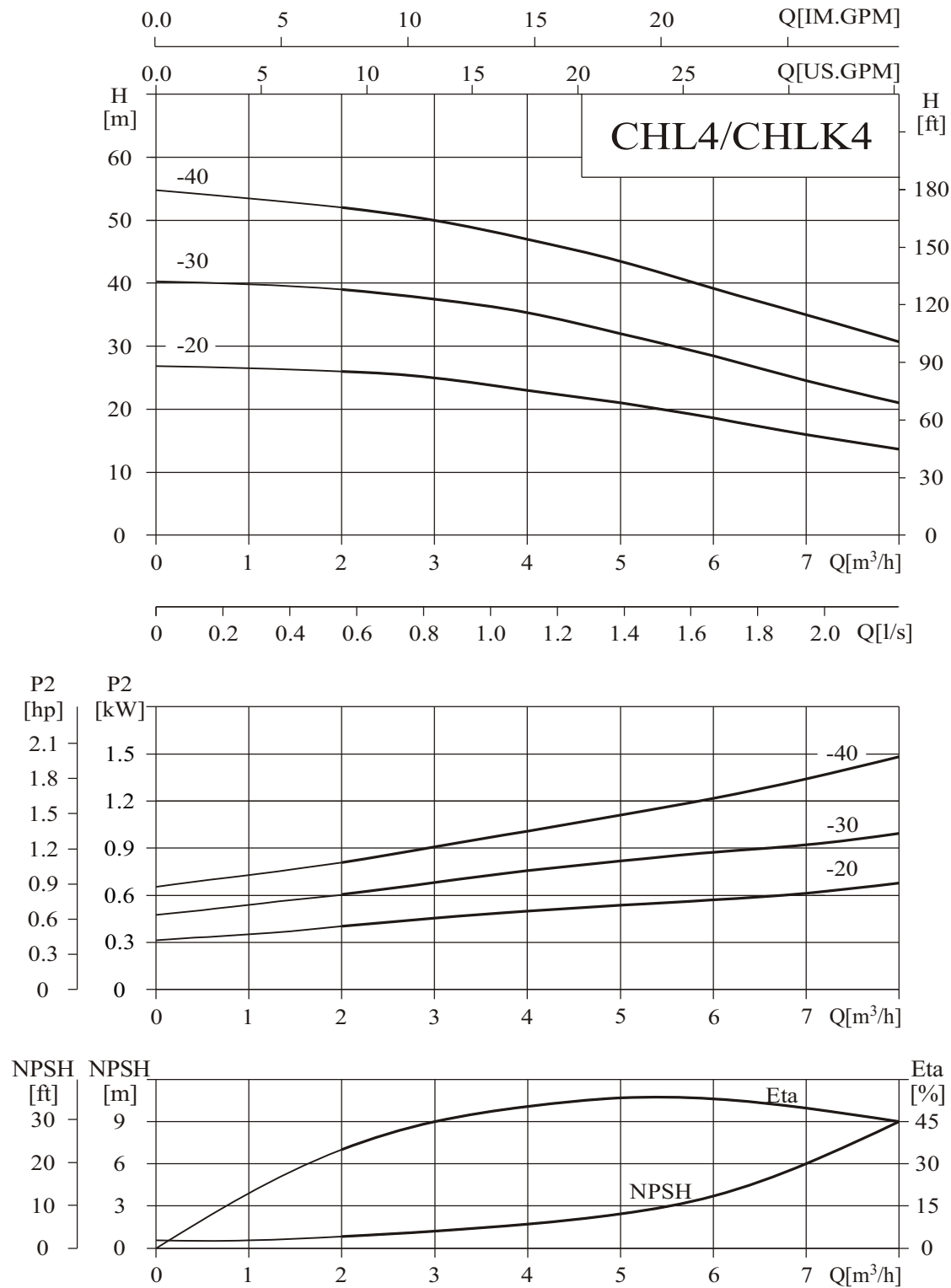

● Performance table

Model	Driving motor		Q (m³/h)	2	3	4	5	6	7	8
	(kW)	(hp)								
CHL4-20	0.75	1	H (m)	26	25	23	21	19	16	14
CHL4-30	1.1	1.5		39	37.5	36	32	28	24	21
CHL4-40	1.5	2		52	50	47	43.5	38.5	35	31

● Installation sketch

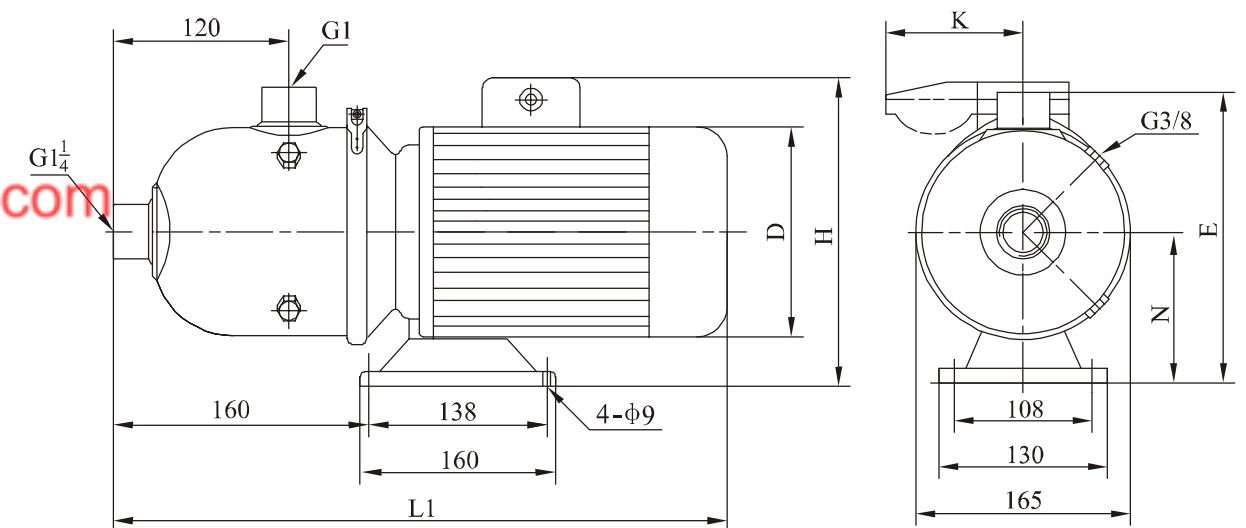

● Size and weight

Motor	Model	Size (mm)						Weight (kg)
		L1	H	N	D	E	K	
Three-phase/ single-phase	CHL4-20	420	230/245	110	160	210	/100	12
	CHL4-30	420	230/245	110	170	210	/100	15
	CHL4-40	470	240/260	118	170	228	/100	20

● Performance curve

ISO9906 Annex A

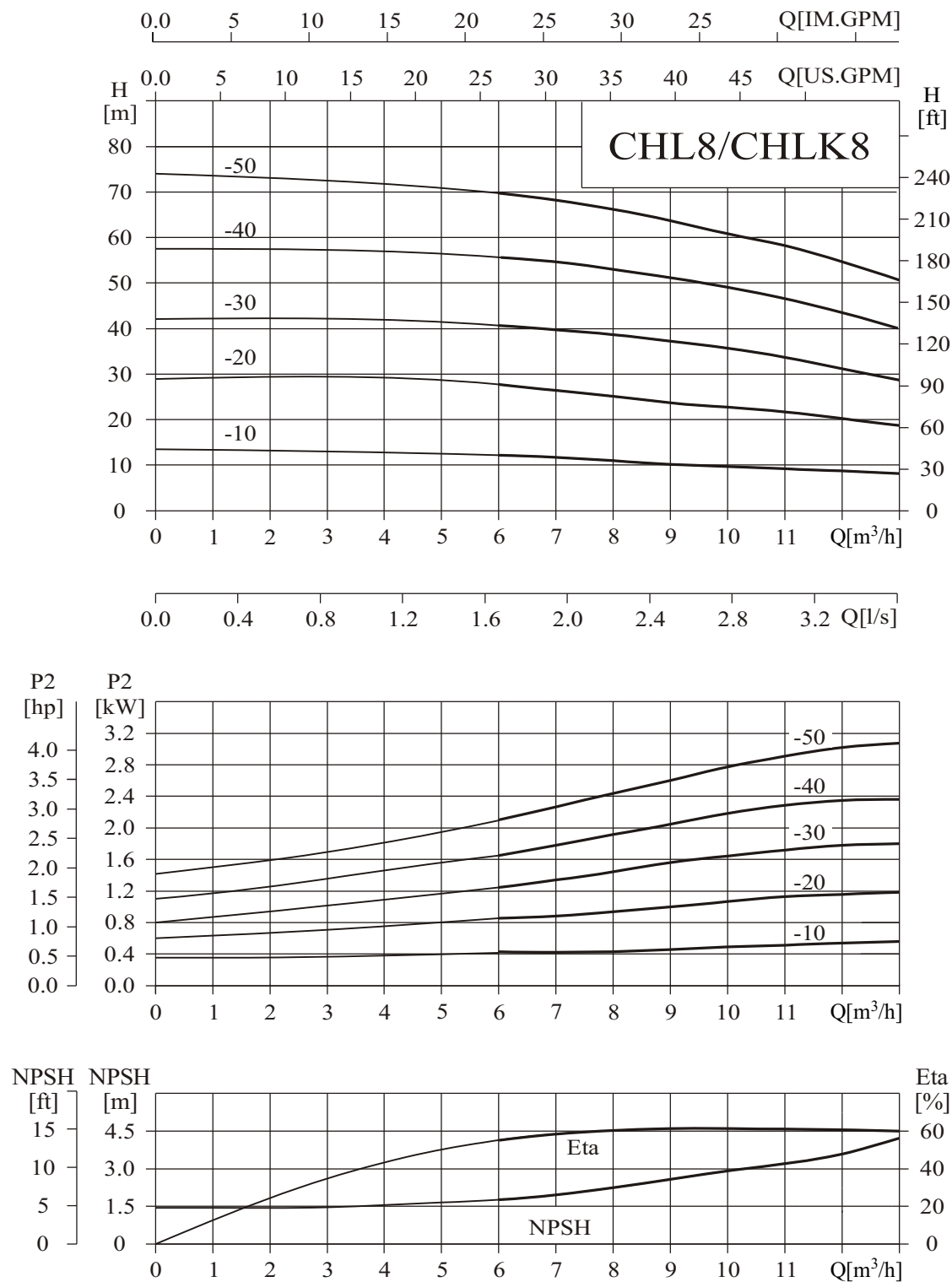

● Performance table

Model	Driving motor		Q (m³/h)	6	7	8	9	10	11	12	13
	(kW)	(hp)									
CHL8-10	0.75	1	H (m)	14.5	13	12	11.5	11	10.5	10	9.5
CHL8-20	1.5	2		29	27	26	25	24	23	21.5	20
CHL8-30	2.2	3		42	41	40	39	37	35	33	30
CHL8-40	3	4		55.5	54.5	53	51	49	46.5	43.5	40
CHL8-50	3	4		71	69.5	67.5	65	63	59	56	52

● Installation sketch

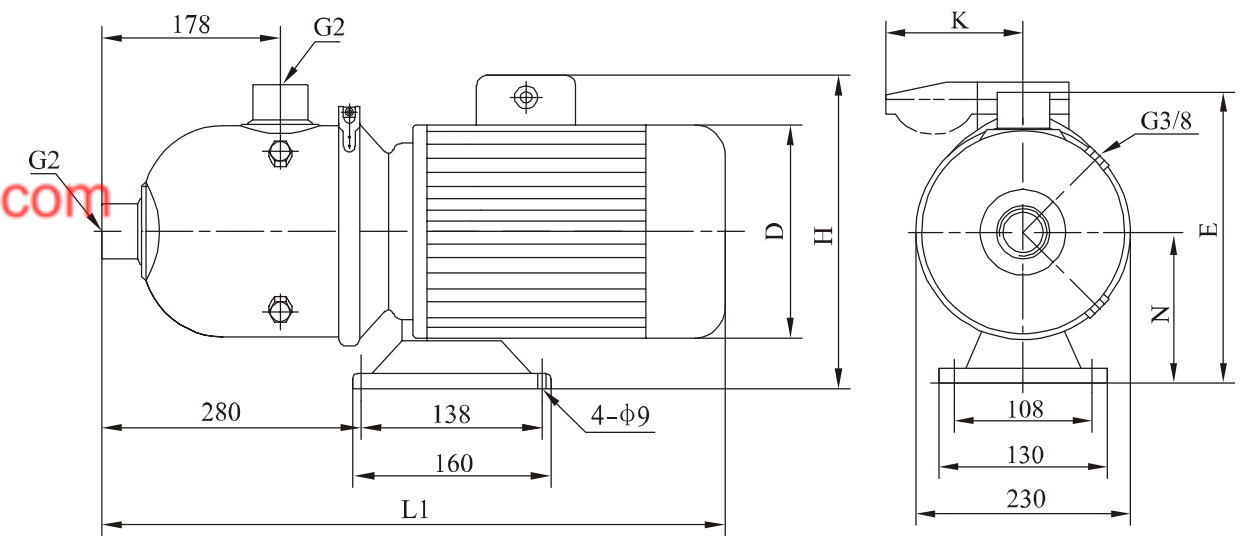

● Size and weight

Motor	Model	Size (mm)						Weight (kg)
		L1	H	N	D	E	K	
Three-phase/ single-phase	CHL8-10	560	230/265	117	160	263	/100	20
	CHL8-20	580	230/270	118	170	264	/100	25
	CHL8-30	580	230/270	118	180	264	/100	25
	CHL8-40	610	270/	128	195	274		30
	CHL8-50	610	270/	128	195	274		30

● Performance curve

ISO9906 Annex A

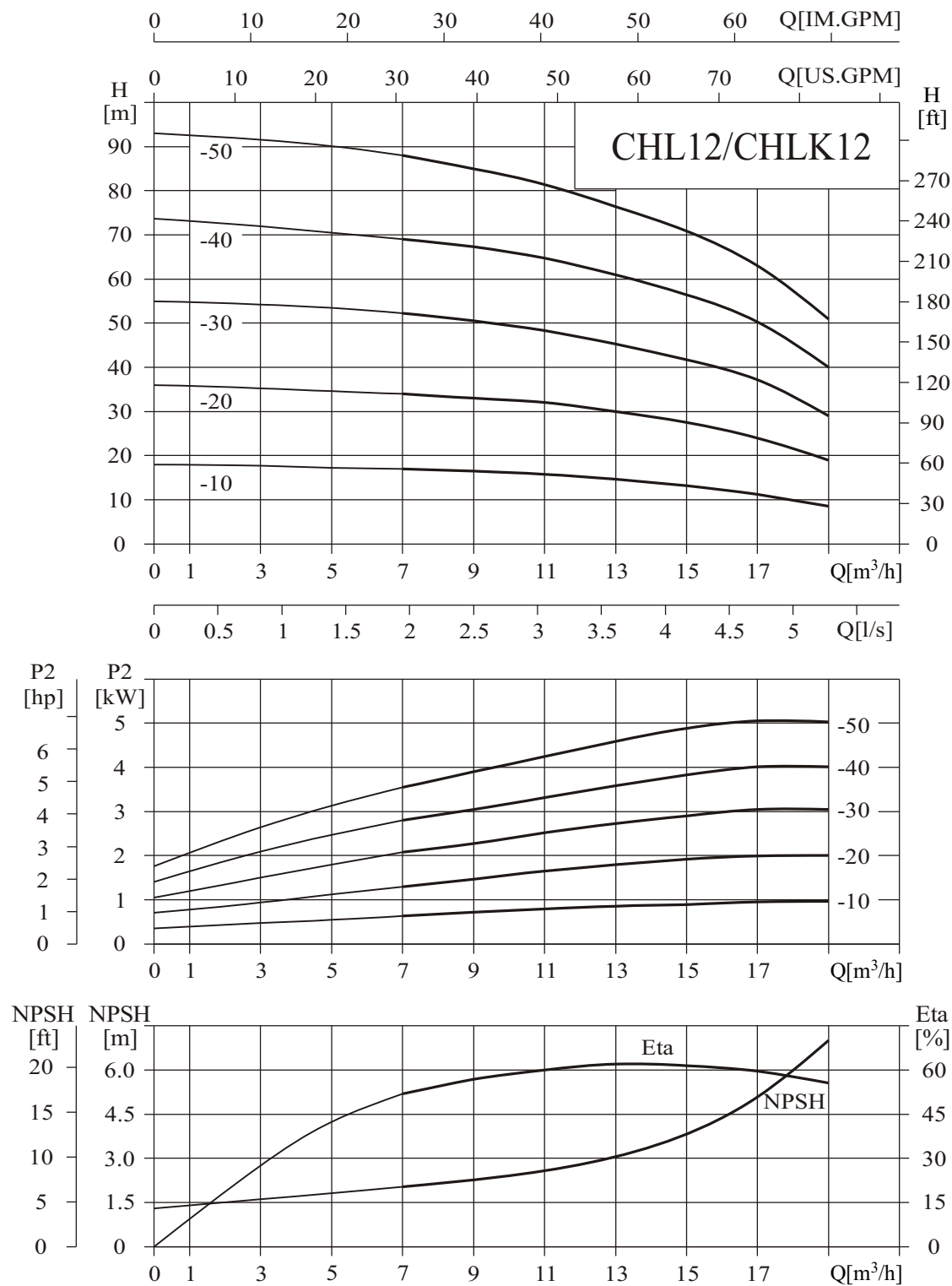

● Performance table

Model	Driving motor		Q (m³/h)	7	9	11	12	13	15	17	19
	(kW)	(hp)									
CHL12-10	1.1	1.5	H (m)	17	16	15	14.5	14	12.5	11	8.5
CHL12-20	2.2	3		34	33	32	31	30	27	24.5	19
CHL12-30	3	4		52.5	50	48.5	47	45	41.5	37.5	29
CHL12-40	4	5.5		69	67.5	65	63	60.5	55	49.5	40
CHL12-50	5.5	7.5		88	85	82	80	76	70	62	50.5

● Installation sketch

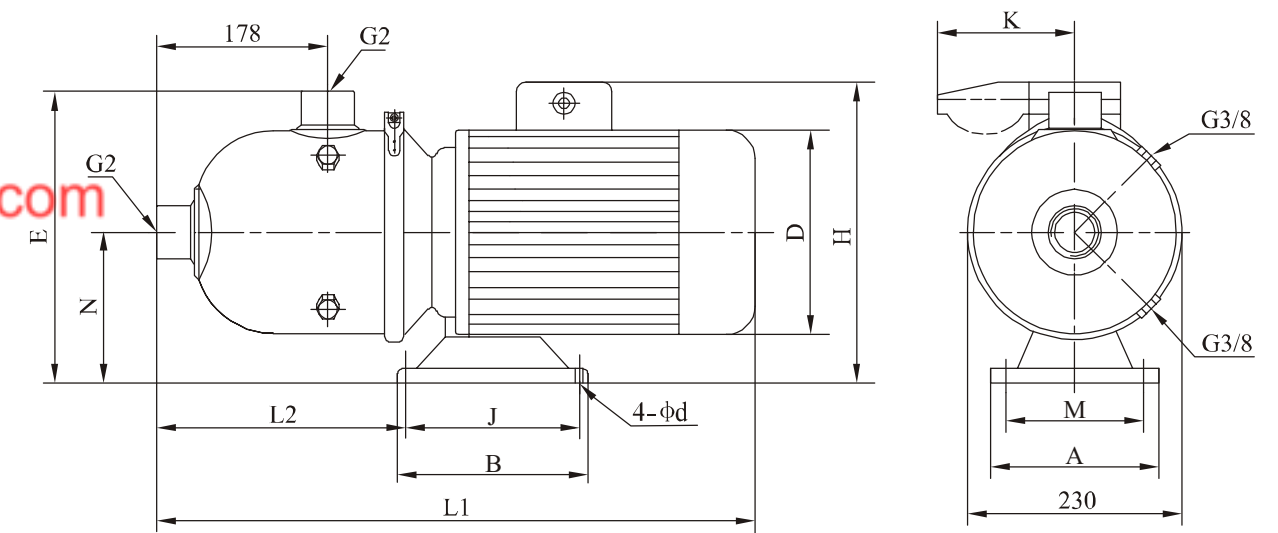

● Size and weight

Motor	Model	Size (mm)											Weight (kg)	
		L1	L2	H	D	E	N	A	M	B	J	d		K
Three-phase/ single-phase	CHL12-10	560	280	230/265	180	268	118	130	108	160	138	9	/100	22
	CHL12-20	580	280	240/270	180	268	118	130	108	160	138	9	/100	25
	CHL12-30	610	270	270/	195	276	126	130	108	160	138	9		32
	CHL12-40	650	360	270/	220	270	120	230	190	170	140	12		44
	CHL12-50	670	375	305/	255	282	132	260	216	190	140	12		58

● Performance curve

ISO9906 Annex A

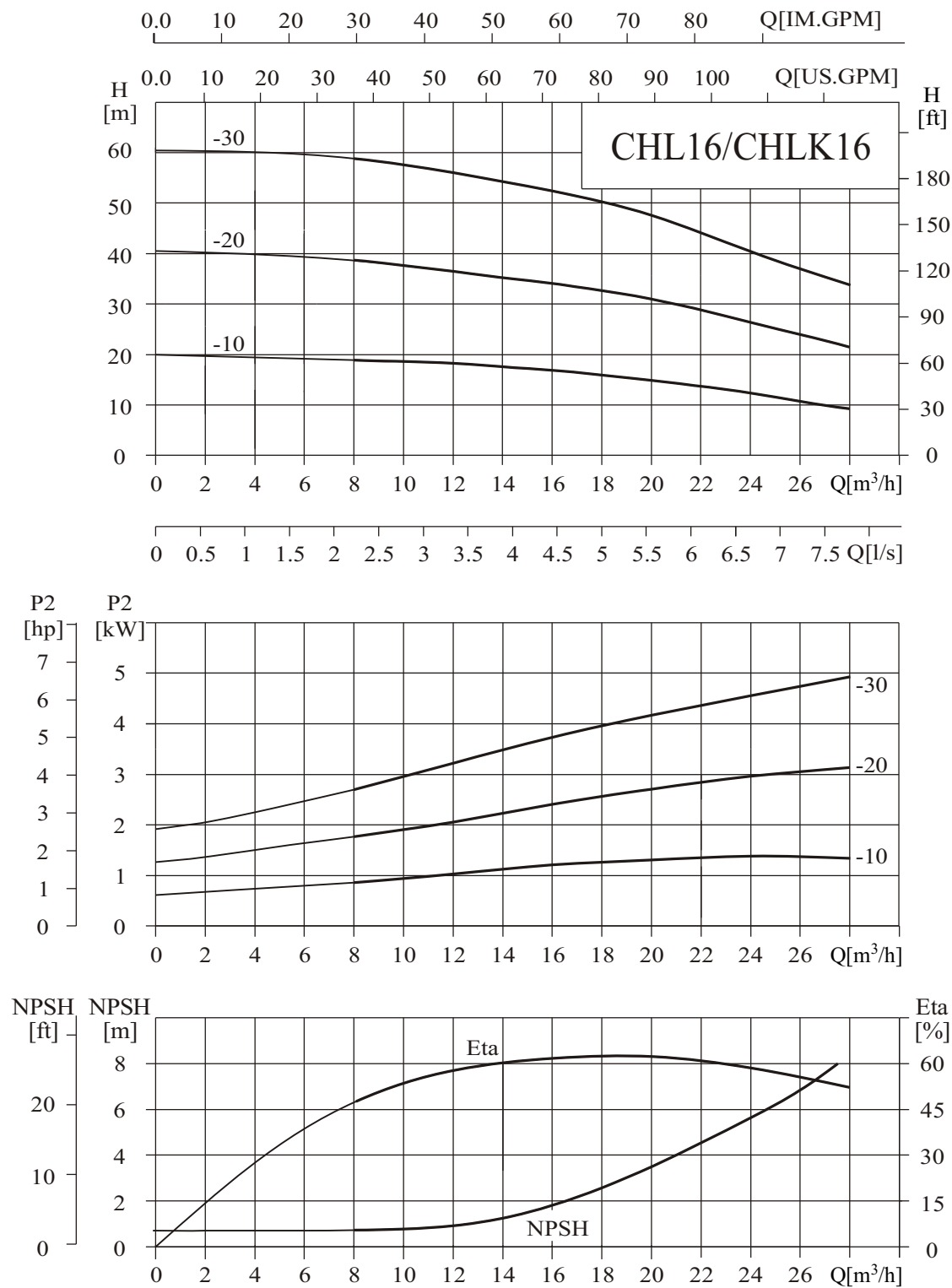

● Performance table

Model	Driving motor		Q (m³/h)	8	12	16	20	24	28
	(kW)	(hp)							
CHL16-10	2.2	4	H (m)	19	18	17	15	12	9
CHL16-20	4.0	5.5		38.5	36.5	34	31	26	21.5
CHL16-30	5.5	7.5		59	56	53.5	47.5	40.3	33.5

● Installation sketch

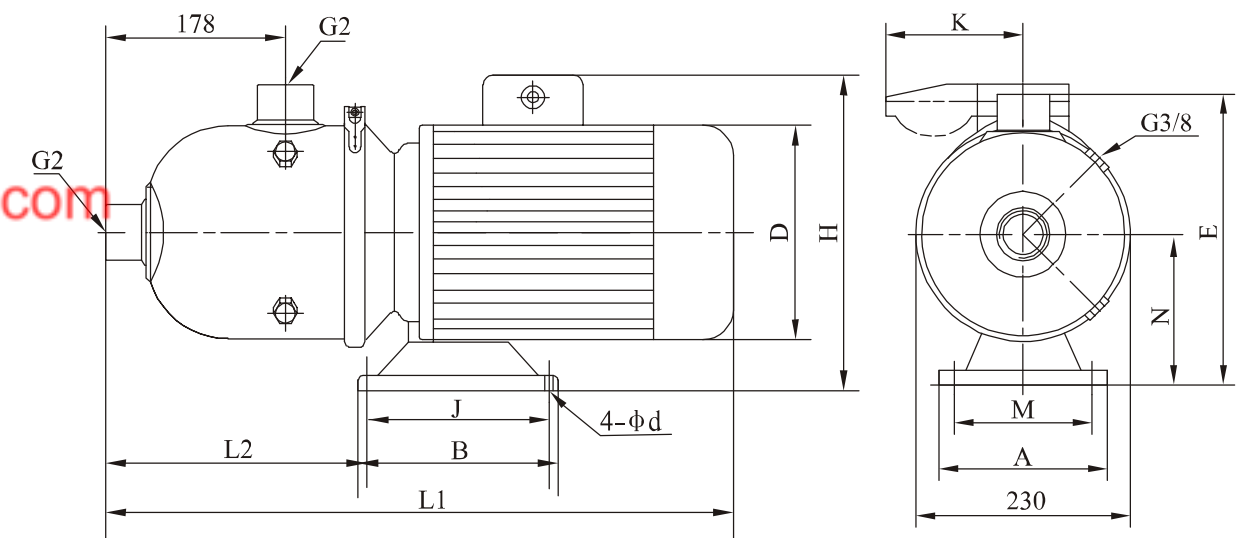

● Size and weight

Motor	Model	Size (mm)											Weight (kg)	
		L1	L2	H	E	B	D	J	A	M	N	d		K
Three-phase/ single-phase	CHL16-10	580	280	230/270	264	160	180	138	130	108	118	9	/100	25
	CHL16-20	650	360	270/	270	170	220	140	230	190	120	12		43
	CHL16-30	670	375	305/	281	190	255	140	260	216	132	12		50

● Performance curve

ISO9906 Annex A

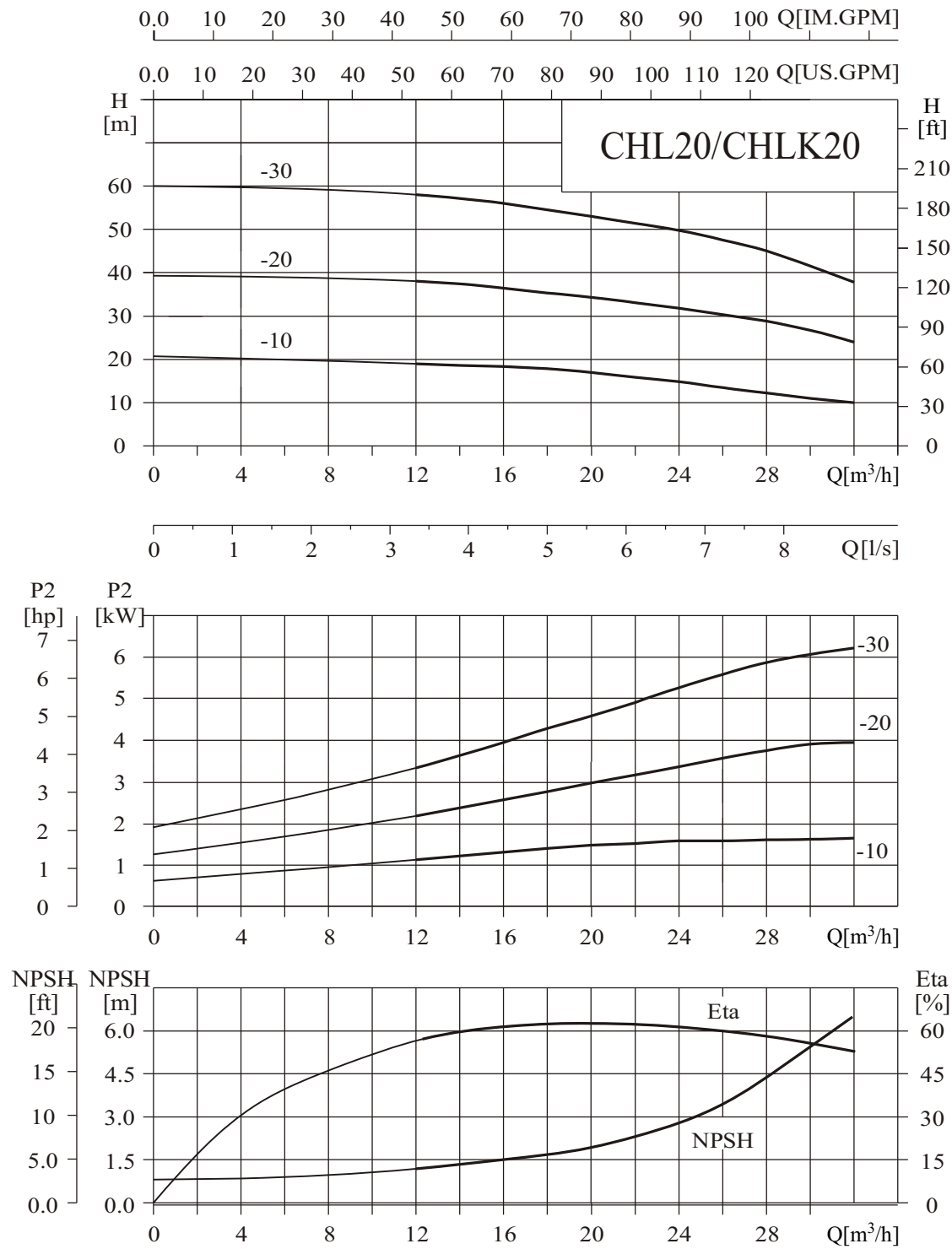

● Performance table

Model	Driving motor		Q (m³/h)	12	14	16	18	20	22	24	26	28	30	32
	(kW)	(hp)		H (m)										
CHL20-10	2.2	3		19	18.5	18	17.5	17	16	15	13.5	12	11	10
CHL20-20	4	5.5		38	37	36	35	34	33	32	30.5	29	26.5	24
CHL20-30	5.5	7.5		58	57	56	55	53	51.4	50	47.5	45	41.6	38

● Installation sketch

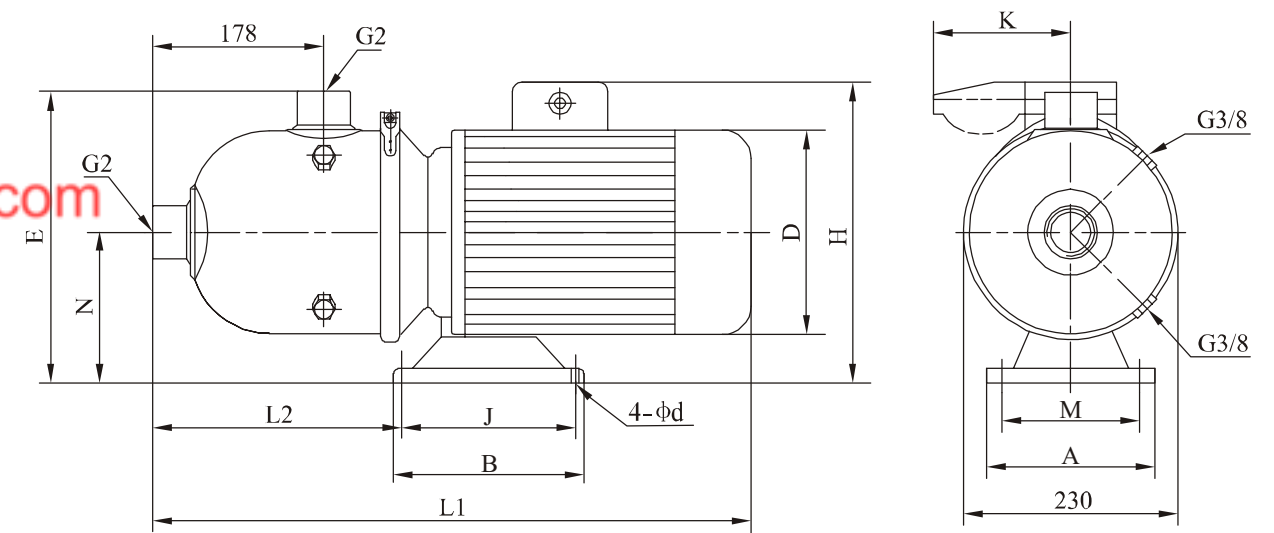

● Size and weight

Motor	Model	Size (mm)												Weight (kg)
		L1	L2	H	D	E	N	A	M	B	J	d	K	
Three-phase/ single-phase	CHL20-10	580	280	240/270	180	268	118	130	108	160	138	9	/100	26
	CHL20-20	650	360	270/	220	270	120	230	190	170	140	12		43
	CHL20-30	670	375	305/	255	282	132	260	216	190	140	12		56

● Performance curve

ISO9906 Annex A

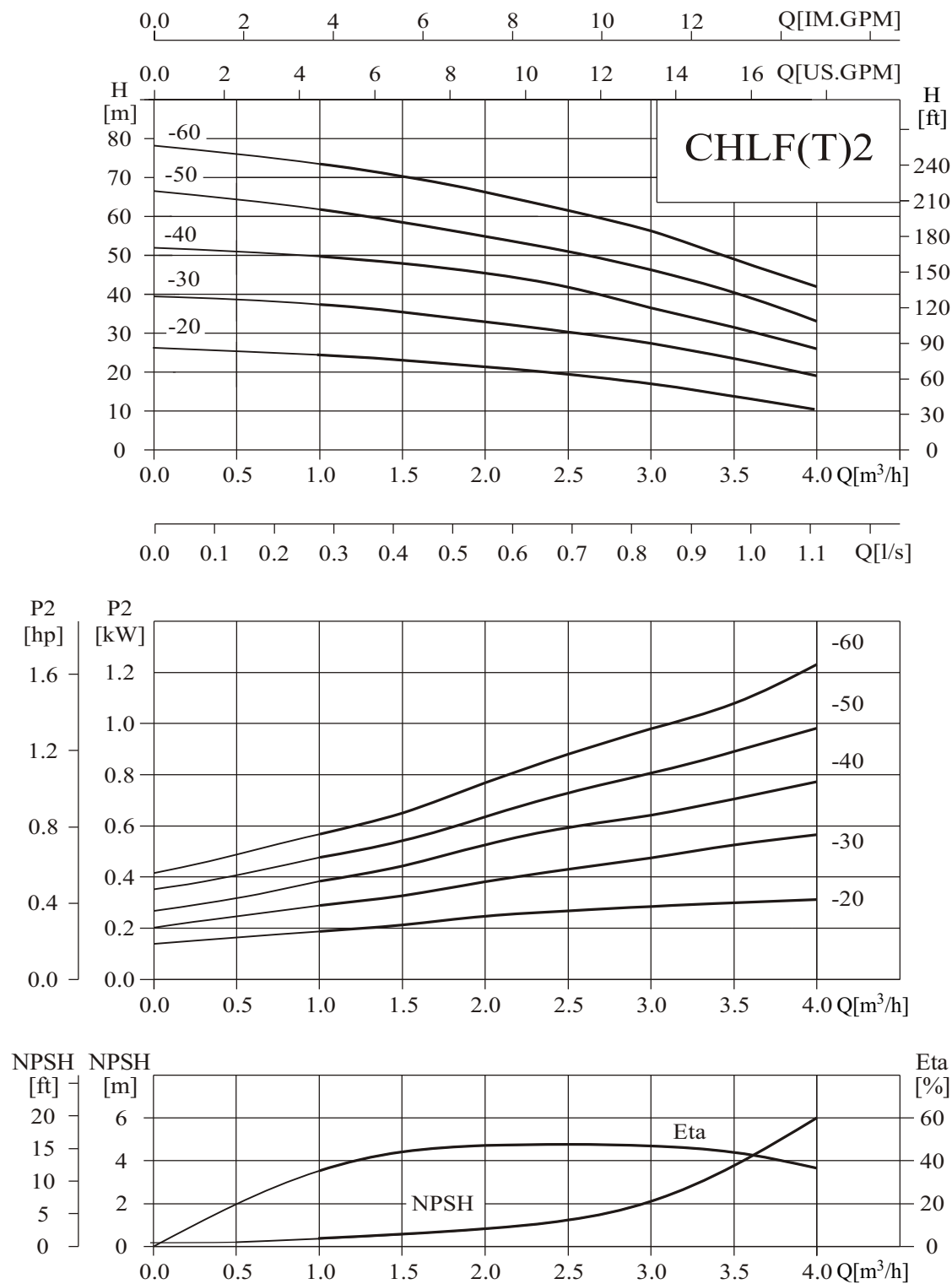

● Performance table

Model	Driving motor		Q (m³/h)	1	1.5	2	2.5	3	3.5	4
	(kW)	(hp)								
CHLF(T)2-20	0.55	0.75	H (m)	24.5	23	21.5	19.5	17	14	10.5
CHLF(T)2-30	0.75	1		37.5	35.5	33	30.5	27.5	23.5	19
CHLF(T)2-40	1.1	1.5		49.5	48	45.5	42	36	32	26
CHLF(T)2-50	1.1	1.5		62	58.5	55	51	46	40.5	33
CHLF(T)2-60	1.5	2		73.5	70.5	66	61.5	56	49	40

● Installation sketch

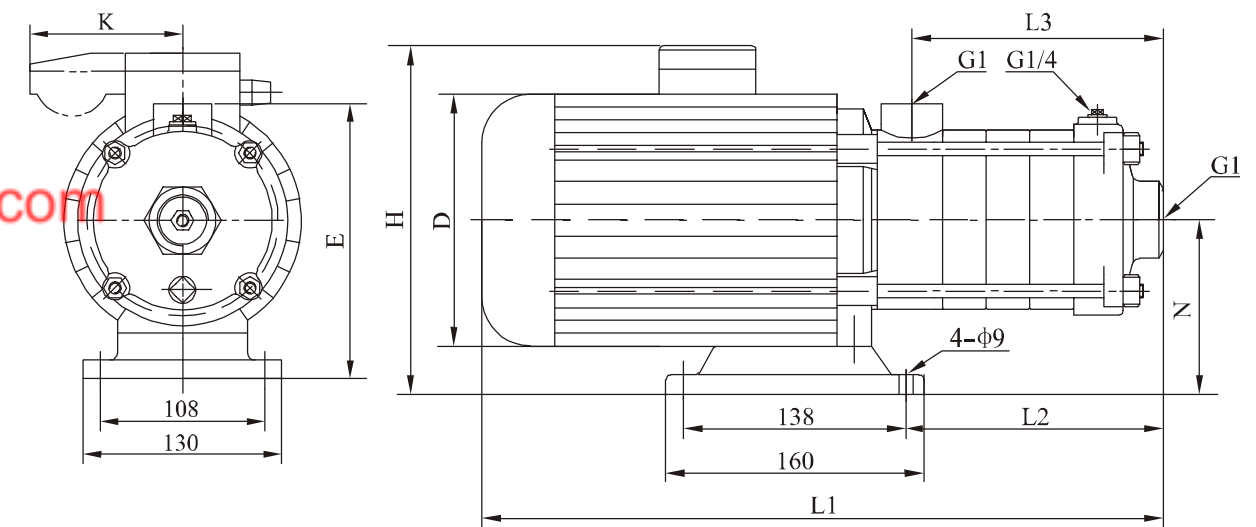

● Size and weight

Motor	Model	Size (mm)								Weight (kg)
		L1	L2	L3	E	H	N	D	K	
Three-phase/ single-phase	CHLF(T)2-20	305	87	84	182	230/230	110	145	/96	15
	CHLF(T)2-30	370	105	102	182	230/245	110	170	/100	17
	CHLF(T)2-40	388	123	120	182	230/245	110	170	/100	17
	CHLF(T)2-50	406	141	138	182	230/245	110	170	/100	17
	CHLF(T)2-60	465	159	156	190	240/260	118	170	/100	20

● Performance curve

ISO9906 Annex A

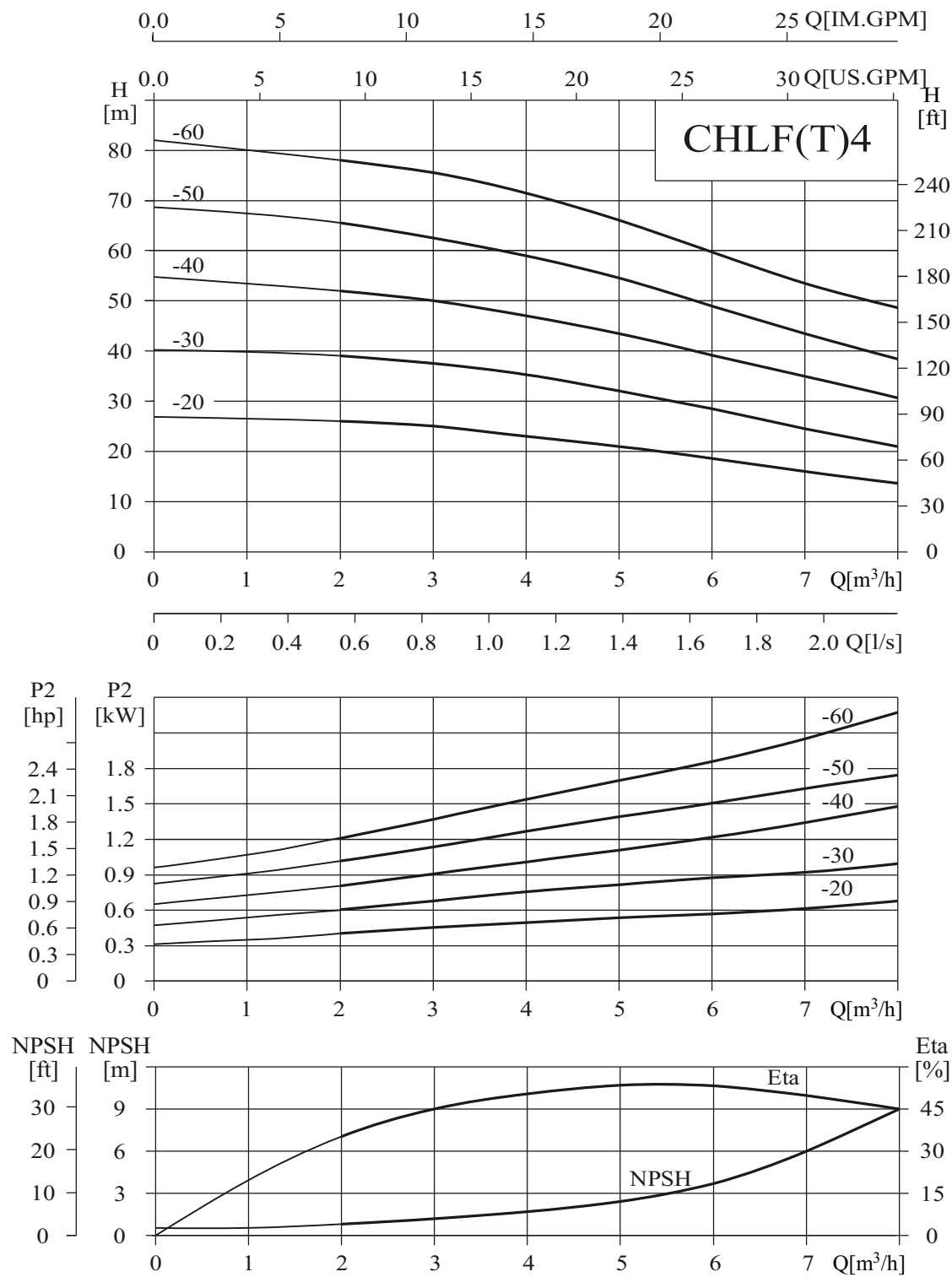

● Performance table

Model	Driving motor		Q (m³/h)	2	3	4	5	6	7	8
	(kW)	(hp)								
CHLF(T)4-20	0.75	1	H (m)	26	25	23	21	19	16	14
CHLF(T)4-30	1.1	1.5		39	37.5	36	32	28	24	21
CHLF(T)4-40	1.5	2		52	50	47	43.5	38.5	35	31
CHLF(T)4-50	2.2	3		65.5	62.5	59	54.5	49	43	39
CHLF(T)4-60	2.2	3		78	75.5	71.5	66.5	59	53.5	47

● Installation sketch

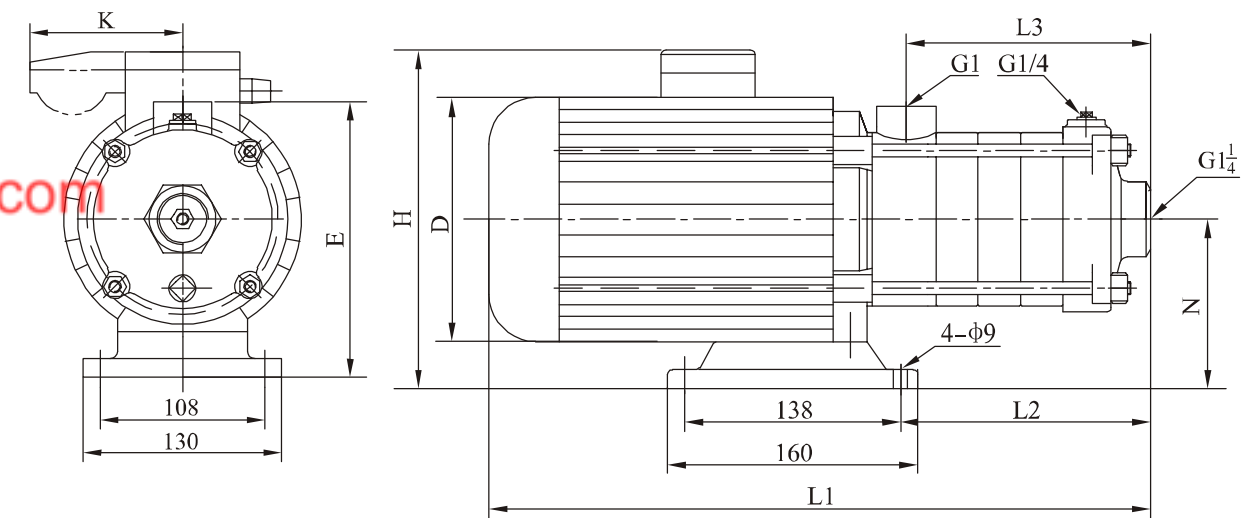

● Size and weight

Motor	Model	Size (mm)								Weight (kg)
		L1	L2	L3	E	H	N	D	K	
Three-phase/ single-phase	CHLF(T)4-20	359	105	102	182	230/245	110	170	/100	15
	CHLF(T)4-30	395	132	129	182	230/245	110	170	/100	17
	CHLF(T)4-40	465	159	156	190	240/260	118	170	/100	20
	CHLF(T)4-50	492	186	183	190	240/260	118	180	/100	25
	CHLF(T)4-60	519	213	210	190	240/260	118	180	/100	25

● Performance curve

ISO9906 Annex A

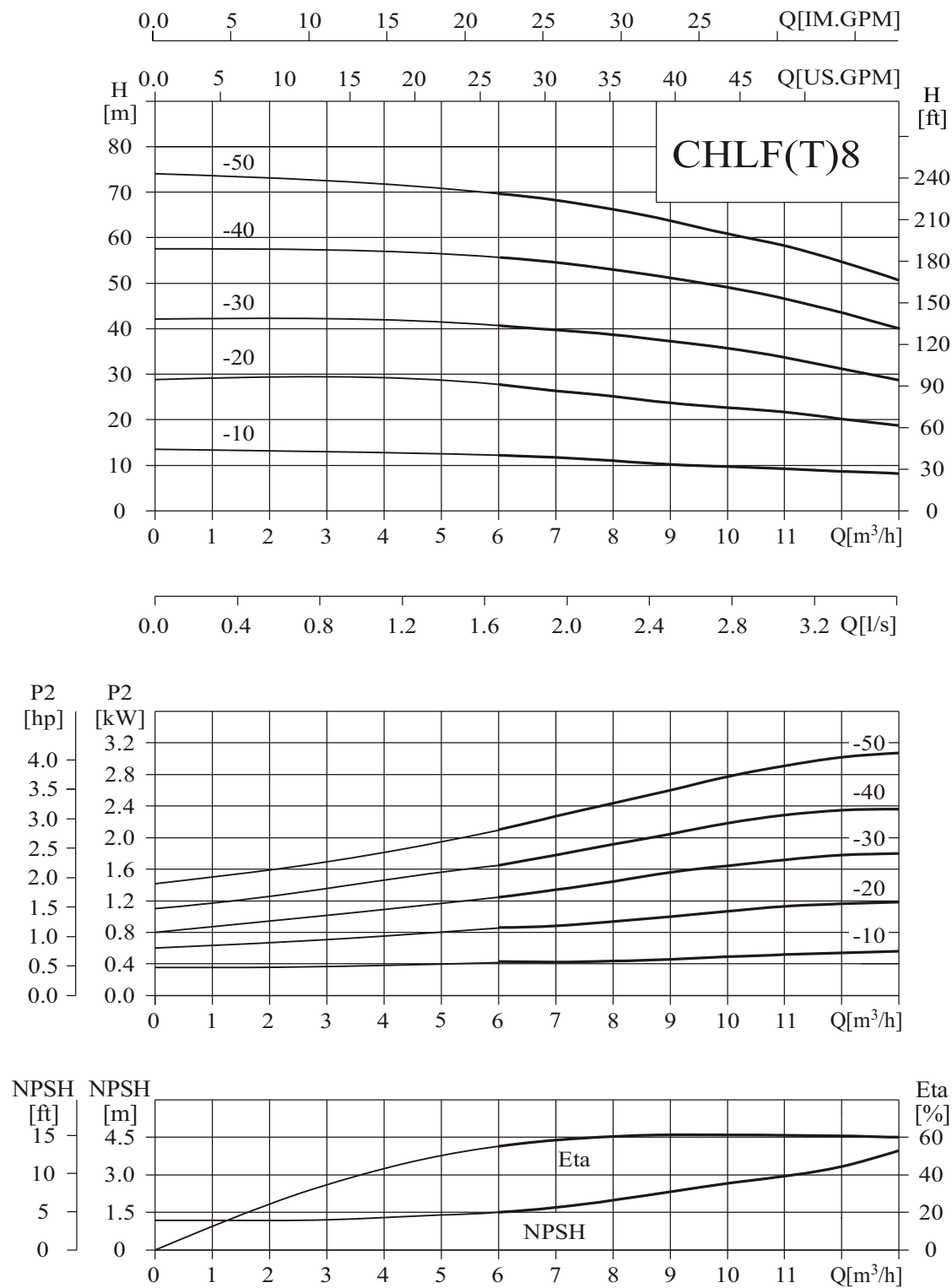

● Performance table

Model	Driving motor		Q (m³/h)	6	7	8	9	10	11	12	13
	(kW)	(hp)									
CHLF(T)8-10	0.75	1	H (m)	14.5	13	12	11.5	11	10.5	10	9.5
CHLF(T)8-20	1.5	2		29	27	26	25	24	23	21.5	20
CHLF(T)8-30	2.2	3		42	41	40	39	37	35	33	30
CHLF(T)8-40	3	4		55.5	54.5	53	51	49	46.5	43.5	40
CHLF(T)8-50	3	4		71	69.5	67.5	65	63	59	56	52

● Installation sketch

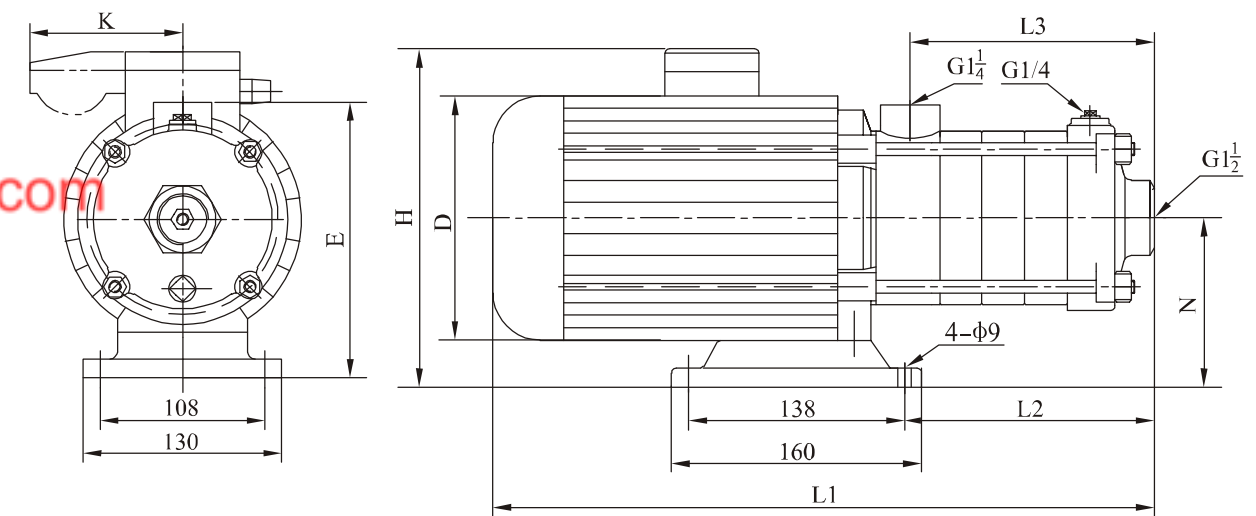

● Size and weight

Motor	Model	Size (mm)								Weight (kg)
		L1	L2	L3	E	H	N	D	K	
Three-phase/ single-phase	CHLF(T)8-10	395	128	108	227	230/265	117	170	/100	22
	CHLF(T)8-20	430	128	108	228	240/270	118	170	/100	25
	CHLF(T)8-30	460	158	138	228	240/270	118	170	/100	27
	CHLF(T)8-40	550	188	168	238	270/	128	195		32
	CHLF(T)8-50	580	218	198	238	270/	128	195		32

● Performance curve

ISO9906 Annex A

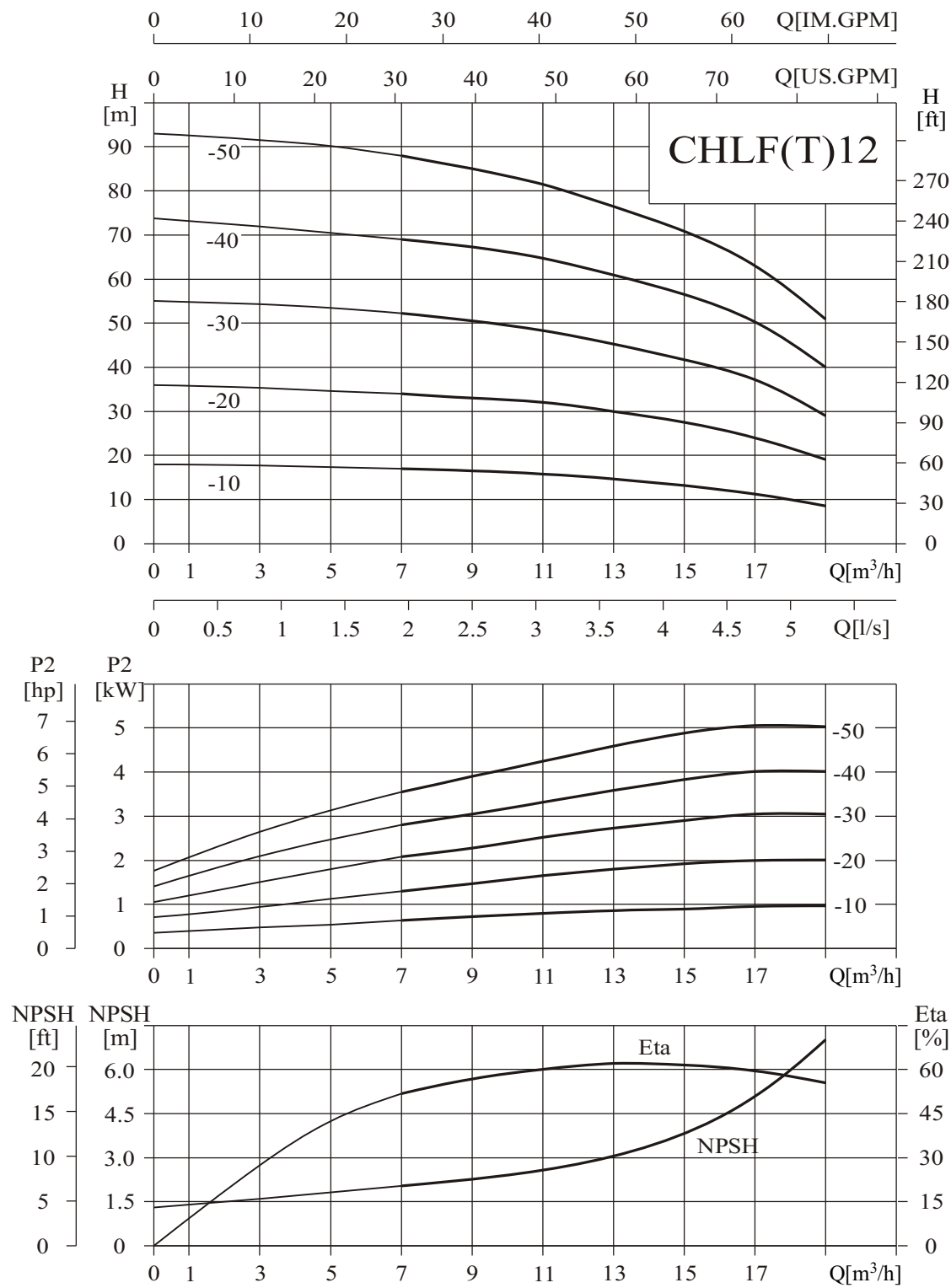

● Performance table

Model	Driving motor		Q (m³/h)	7	9	11	12	13	15	17	19
	(kW)	(hp)									
CHLF(T)12-10	1.1	1.5	H (m)	17	16	15	14.5	14	12.5	11	8.5
CHLF(T)12-20	2.2	3		34	33	32	31	30	27	24.5	19
CHLF(T)12-30	3	4		52.5	50	48.5	47	45	41.5	37.5	29
CHLF(T)12-40	4	5.5		69	67.5	65	63	60.5	55	49.5	40
CHLF(T)12-50	5.5	7.5		88	85	82	80	76	70	62	50.5

● Installation sketch

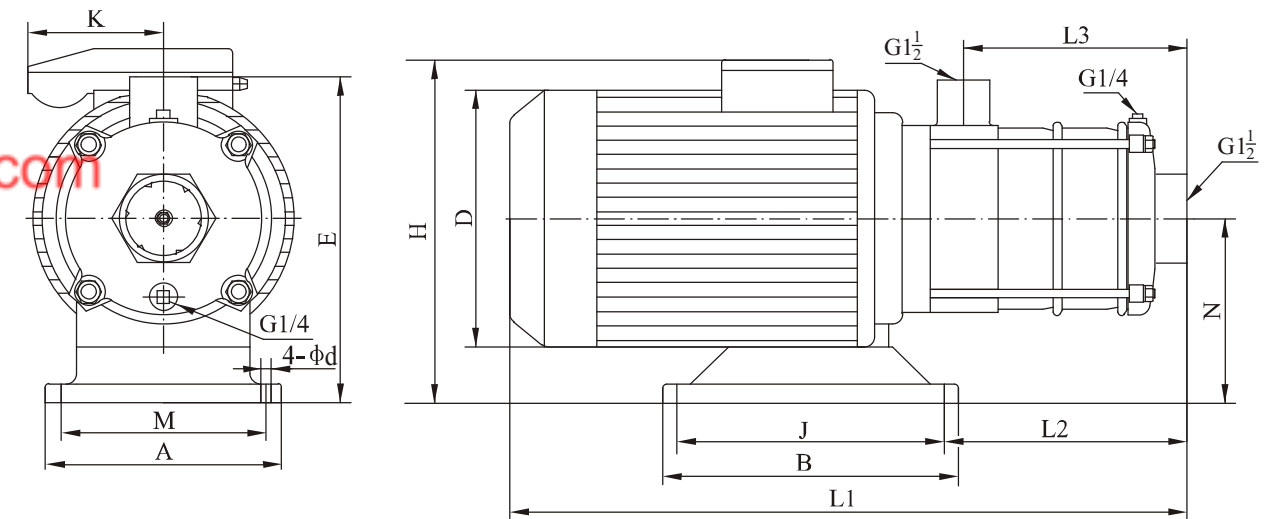

● Size and weight

Motor	Model	Size (mm)													Weight (kg)
		L1	L2	L3	H	D	E	N	A	M	B	J	d	K	
Three-phase/ single-phase	CHLF(T)12-10	395	126	108	230/265	170	227	117	130	108	160	138	9	/100	22
	CHLF(T)12-20	430	126	108	240/270	180	228	118	130	108	160	138	9	/100	25
	CHLF(T)12-30	510	156	138	270/	195	240	130	130	108	160	138	9		32
	CHLF(T)12-40	565	285	168	270/	220	230	120	230	190	170	140	12		44
	CHLF(T)12-50	620	325	198	305/	255	242	132	260	216	190	140	12		58

● Performance curve

ISO9906 Annex A

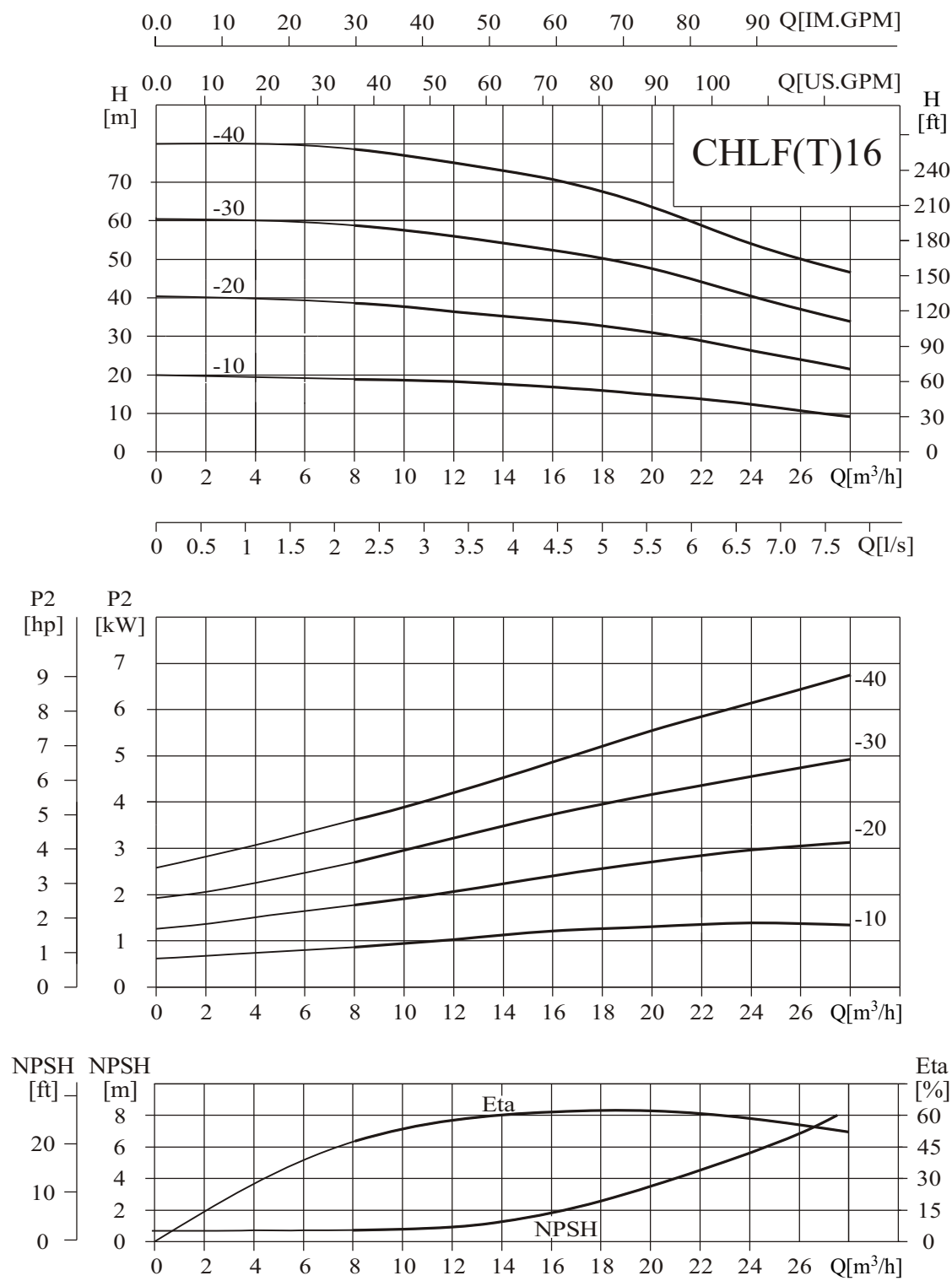

● Performance table

Model	Driving motor		Q (m³/h)	8	12	16	20	24	28
	(kW)	(hp)							
CHLF(T)16-10	2.2	3	H (m)	19	18	17	15	12	9
CHLF(T)16-20	4	5.5		38.5	36.5	34	31	26	21.5
CHLF(T)16-30	5.5	7.5		59	56	53.5	47.5	40.3	33.5
CHLF(T)16-40	7.5	10		78.5	75	72	64	54	46.5

● Installation sketch

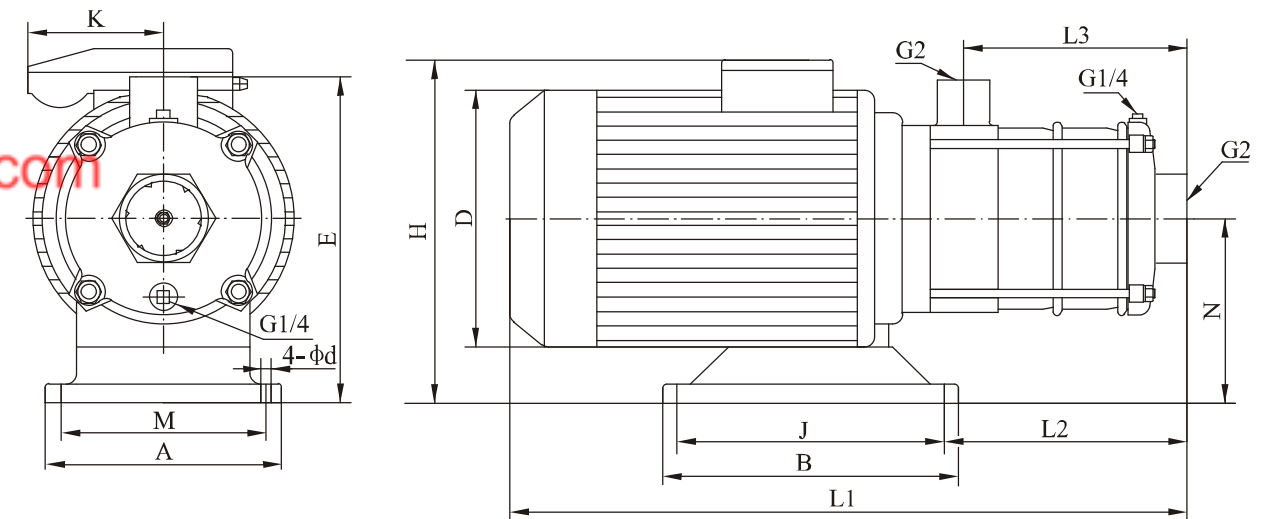

● Size and weight

Motor	Model	Size (mm)													Weight (kg)
		L1	L2	L3	H	D	E	N	A	M	B	J	d	K	
Three-phase/ single-phase	CHLF(T)16-10	455	151	126	240/270	180	228	118	131	108	161	138	9	/100	26
	CHLF(T)16-20	531	249	126	270/	220	230	120	230	190	170	140	12		43
	CHLF(T)16-30	600	310	171	305/	255	242	132	260	216	190	140	12		56
	CHLF(T)16-40	645	355	216	305/	255	242	132	260	216	190	140	12		63

● Performance curve

ISO9906 Annex A

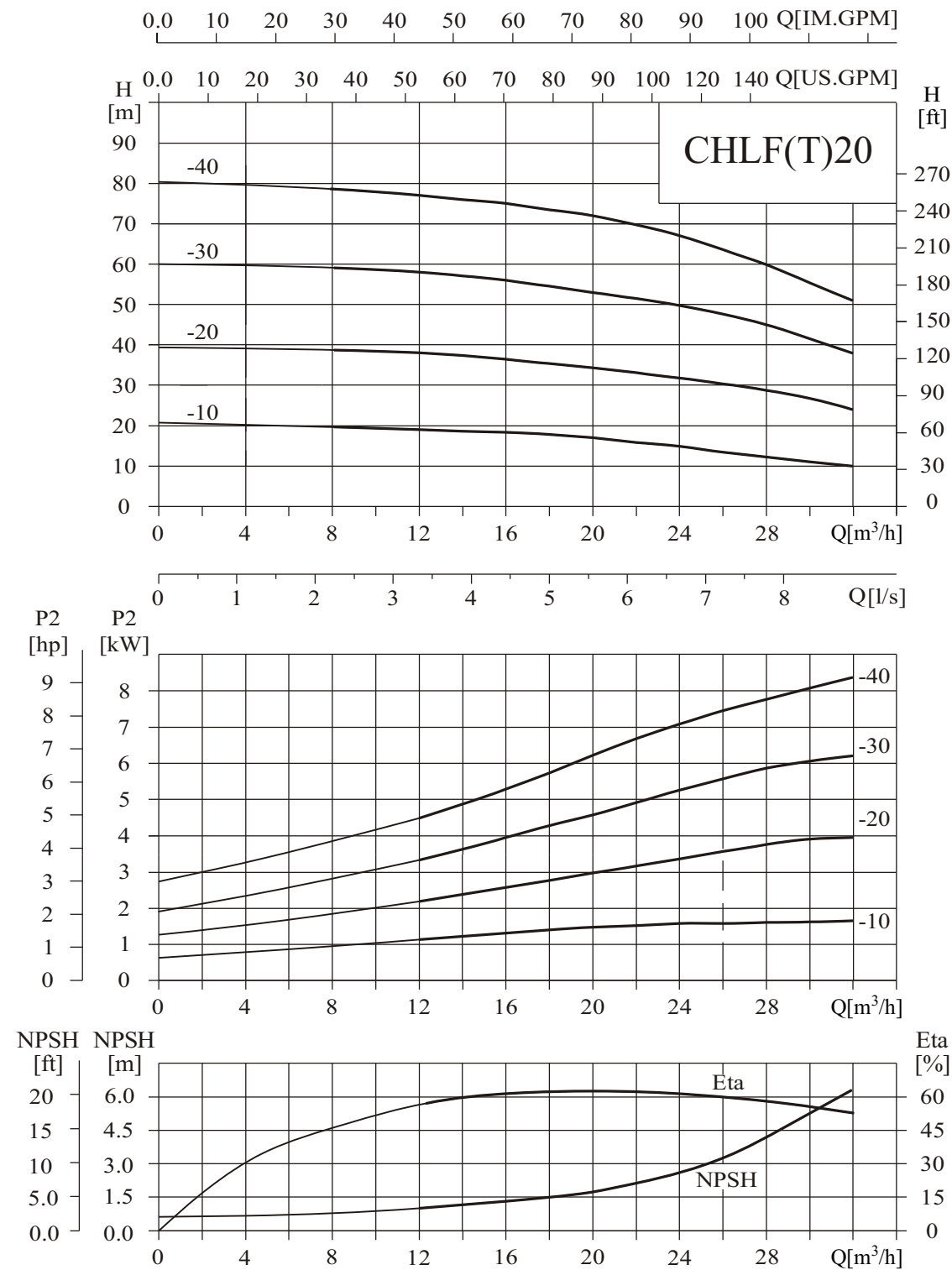

● Performance table

Model	Driving motor		Q (m³/h)	12	14	16	18	20	22	24	26	28	30	32
	(kW)	(hp)		H (m)										
CHLF(T)20-10	2.2	3		19	18.5	18	17.5	17	16	15	13.5	12	11	10
CHLF(T)20-20	4	5.5		38	37	36	35	34	33	32	30.5	29	26.5	24
CHLF(T)20-30	5.5	7.5		58	57	56	55	53	51.4	50	47.5	45	41.6	38
CHLF(T)20-40	7.5	10		77	76	75	73.5	72	70	67	65	60.5	56	51

● Installation sketch

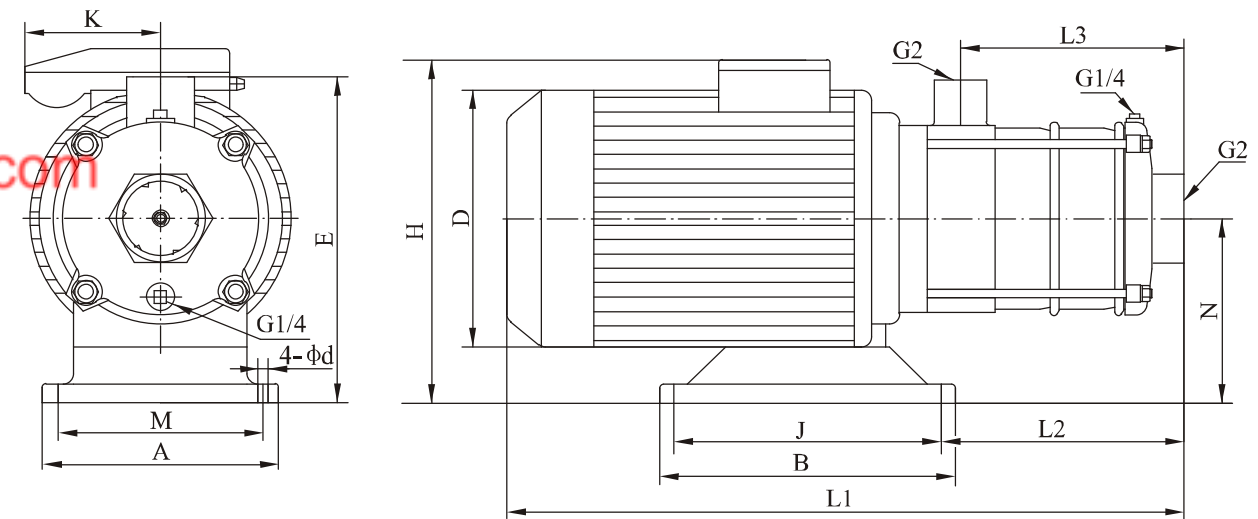

● Size and weight

Motor	Model	Size (mm)												Weight (kg)	
		L1	L2	L3	H	D	E	N	A	M	B	J	d		K
Three-phase/ single-phase	CHLF(T)20-10	455	151	126	240/270	180	228	118	130	108	160	138	9	/100	26
	CHLF(T)20-20	531	249	126	270/	220	230	120	230	190	170	140	12		43
	CHLF(T)20-30	600	310	171	305/	255	242	132	260	216	190	140	12		56
	CHLF(T)20-40	645	355	216	305/	255	242	132	260	216	190	140	12		63

